

TECHNICAL MANUAL

**TRANSPORTABILITY GUIDANCE
PATRIOT MISSILE SYSTEM**

Approved for public release; distribution is unlimited

**HEADQUARTERS, DEPARTMENT OF THE ARMY
MARCH 1992**

Technical Manual }
 No. 55-1430-601-14 }

Headquarters
 Department of the Army
 Washington, DC, 3 March 1992

**TRANSPORTABILITY GUIDANCE
 PATRIOT MISSILE SYSTEM**

Approved for public release; distribution is unlimited.

	<i>Paragraph</i>	<i>Page</i>
CHAPTER 1. INTRODUCTION		
Purpose and Scope	1-1	1-1
Safety	1-2	1-1
Definitions of Warnings, Cautions, and Notes	1-3	1-1
Reporting of Recommendations and Comments	1-4	1-1
CHAPTER 2. TRANSPORTABILITY DATA		
Scope	2-1	2-1
Description and Transportability Drawings	2-2	2-1
Unusual and Hazardous Characteristics	2-3	2-38
CHAPTER 3. SAFETY		
General.....	3-1	3-1
Specific Safety Requirements	3-2	3-1
CHAPTER 4. AIR TRANSPORTABILITY GUIDANCE		
Scope	4-1	4-1
Maximum Utilization of Aircraft	4-2	4-1
Applicability.....	4-3	4-1
Safety	4-4	4-1
Preparation of Equipment	4-5	4-1
Transport of PATRIOT Missile System Components in C-5 Aircraft.....	4-6	4-2
Transport of PATRIOT Missile System Components in C-141B Aircraft ..	4-7	4-11
CHAPTER 5. HIGHWAY TRANSPORTABILITY GUIDANCE		
Section I. GENERAL		
Scope	5-1	5-1
Safety	5-2	5-1
General.....	5-3	5-1
II. SELF-PROPELLED MOVEMENT		
US Highways	5-4	5-1
European Highways	5-5	5-1
Other Countries	5-6	5-1
III. TRANSPORT BY SEMITRAILER		
General.....	5-7	5-1
Preparation for Transport	5-8	5-2
Loading and Tiedown on Semitrailer	5-9	5-2
CHAPTER 6. MARINE AND TERMINAL TRANSPORTABILITY GUIDANCE		
Section I. GENERAL		
Scope	6-1	6-1
Safety	6-2	6-1
Water Shipment	6-3	6-1
II. LOADING AND SECURING		
General Rules for Stowing.....	6-4	6-1
Special Design Ships	6-5	6-21
Barges and Lighters	6-6	6-24
Landing Ships, Landing Craft, and Amphibious Vehicles	6-7	6-24
CHAPTER 7. RAIL TRANSPORTABILITY GUIDANCE		
Section I. GENERAL		
Scope	7-1	7-1
Safety	7-1	7-1

	<i>Paragraph</i>	<i>Page</i>
II. TRANSPORT ON CONUS RAILWAYS		
General.....	7-3	7-1
Preparation for Loading.....	7-4	7-1
Loading on General-Purpose Railcars	7-5	7-1
Loading on Flatcars with Chain Tiedown	7-6	7-30
III. TRANSPORT ON FOREIGN RAILWAYS		
General.....	7-7	7-31
Transport on Foreign-Service Flatcars	7-8	7-31
APPENDIX REFERENCES		A-1

List of Illustrations

<i>Figure</i>	<i>Title</i>	<i>Page</i>
2-1	Radar set, AN/MPQ-53, semitrailer-mounted, towed by the M983 truck-tractor	2-2
2-2	M983, 10-ton, 8x8 truck-tractor	2-3
2-3	RS M860A1 semitrailer, with outriggers in transport position.....	2-4
2-4	Radar set, AN/MPQ-53, removed from semitrailer.....	2-5
2-5	Shelter-mounted engagement control station.....	2-7
2-6	Engagement control station mounted on an M927	2-8
2-7	Information and coordination central mounted on an M927	2-10
2-8	Shelter-mounted information and coordination central	2-11
2-9	Launching station M901, semitrailer-mounted, towed by an M983 truck-tractor	2-13
2-10	Launching station M901, mounted on an M860A1 semitrailer, with generator and outriggers in place	2-14
2-11	Launching station M901, mounted on an M860A1 semitrailer with landing gear retracted and rear outriggers removed	2-15
2-12	Outriggers removed from the LS M860A1 semitrailer	2-16
2-13	Large repair parts transporter, M977	2-18
2-14	Battalion maintenance center AN/TSM-164, battery maintenance center AN/TSM-163, or small repair parts transporter M1032, mounted in a modified M373A2 semitrailer van.....	2-20
2-15	Battalion maintenance center AN/TSM-164, battery maintenance center AN/TSM-163, or small repair parts transporter, M1032, semitrailer-van-mounted towed by an M932	2-21
2-16	M932, 5-ton, 6X6 truck-tractor	2-22
2-17	Shelter-mounted communication relay group on an M927	2-24
2-18	Communication relay group AN/MRC-137, shelter-mounted	2-25
2-19	M927, 5-ton, 6X6 truck	2-26
2-20	Antenna mast group mounted on the M942.....	2-28
2-21	Antenna mast group.....	2-29
2-22	M942 and M942A1, 5-ton, 6X6 truck chassis.....	2-30
2-23	Mast restraint and blocking applied to antenna mast group for all modes of transport	2-31
2-24	Electrical power plant AN/MJQ-24, mounted on an M942	2-33
2-25	Electrical power unit (EPU II) PU-789/M, trailer-mounted	2-35
2-26	Side and end views of missile round (MR) canister	2-37
4-1	Typical tiedown diagram for the ECS, ICC, MC (Con Mnt), EPP, CRG, and AMG mounted on 5-ton trucks in C-5 aircraft.....	4-4
4-2	Typical tiedown diagram for the M983, M977, and M985E1 vehicles in C-5 aircraft	4-5
4-3	Typical tiedown diagram for the PATRIOT trailer-mounted EPUs in C-5 aircraft	4-7
4-4	Typical tiedown diagram for the PATRIOT semitrailer-mounted RS and IS towed by an M983 truck-tractor in C-5 aircraft	4-9
4-5	Typical tiedown diagram for the PATRIOT semitrailer-mounted MC (Btry), MC (Bn), and SRPT, towed by an M931 or M932 truck-tractor, in C-5 aircraft	4-10
4-6	Typical tiedown diagram for the PATRIOT 5-ton cargo trucks in C-141B aircraft.....	4-13
4-7	Typical tiedown diagram for the PATRIOT shelter-mounted components secured to three married HCU-6/E (463L) pallets for loading in C-141B aircraft	4-14
4-8	Typical tiedown diagram for the M983, M977, M985E1 10-ton vehicles in C-141B aircraft	4-15
4-9	Typical tiedown diagram for the PATRIOT trailer-mounted EPUs in C-141B aircraft	4-18
4-10	Support shoring assemblies required for pallet/platform loading the RS for transport in C-141B aircraft	4-20
4-11	Three-quarter view showing assembled shoring for pallet/platform loading the RS for air transport.....	4-21
4-12	Tiedown diagram for the pallet/platform-loaded RS in C-141B aircraft	4-22
4-13	Tiedown diagram for the M860A1 semitrailer in C-141B aircraft.....	4-24
4-14	Four LS outriggers packaged, unitized, and secured to one HCU-6/E pallet.....	4-25
4-15	LS electrical power unit secured to one HCU-6/E pallet	4-26

List of Illustrations-Continued

<i>Figure</i>	<i>Title</i>	<i>Page</i>
5-1	Blocking and tiedown diagram for the M985E1, M983, or M977 on an M872 semitrailer	5-3
5-2	Blocking and tiedown diagram for the M942 chassis and the M927, M928, M931, and M932 trucks and truck-tractors on an M872 semitrailer (side)	5-6
5-3	Blocking and tiedown diagram for the M942 chassis and the M927, M928, - M931, and M932 trucks and truck tractors on an M872 semitrailer tend)	5-7
5-4	Blocking and tiedown details.....	5-8
5-5	Side and rear views of blocking and tiedown of the M860A1 semitrailer on an M870 semitrailer	5-9
5-6	Blocking and tiedown details for the M1860A1 semitrailer	5-10
5-7	Blocking and tiedown of the PATRIOT trailers on an M127A1 semitrailer	5-13
5-8	Blocking and tiedown details for the PATRIOT trailers.....	5-14
5-9	Blocking and tiedown of PATRIOT shelter-mounted ECS, ICC, MC (Con). or CRG on an M269A1 or M270A1 semitrailer	5-17
5-10	Blocking and tiedown of RS on an M269A1 or M270A1 semitrailer	5-18
5-11	Blocking and tiedown of PATRIOT platform- or base-mounted components on an M269A1 or M270A1 semitrailer	5-19
6-1	Typical lifting diagram for the M977	6-3
6-2	Lifting diagram for the M985E1, rear.....	6-4
6-3	Typical lifting diagram for the M927, M928, and M942.....	6-5
6-4	Typical lifting diagram for the M942 chassis, M931, and M932	6-6
6-5	Lifting diagram for the M860A1 semitrailer using a four-leg sling	6-8
6-6	Lifting diagram for the RS and the shelter-mounted control centers (ICC, ECS, and CRGI	6-9
6-7	Lifting diagram for the RS mounted on an M860A1 semitrailer using eight wire rope slings legs and two spreader bars.....	6-10
6-8	Lifting diagram for the EPU II using a six-wire sling and one spreader bar	6-11
6-9	Blocking and tiedown of the M985E1, M953, and M977 vehicles in a general cargo vessel.....	6-12
6-10	Blocking and tiedown of M927, M925, M942, M931, and M932 vehicles in a general cargo vessel	6-13
6-11	Typical blocking and tiedown of the RS and LS mounted on an M860A1 semitrailer in a general cargo vessel	6-14
6-12	Typical blocking and tiedown of the PATRIOT trailer-mounted components in a general cargo vessel.....	6-15
6-13	Typical blocking and tiedown of the PATRIOT semitrailer mounted components in a general cargo vessel	6-20
6-14	Typical Peck & Hale 9,800- and 17,000-pound-capacity patented lashing gear	6-22
6-15	Typical Peck & Hale 35,000- and 70,000-pound-capacity patented lashing gear	6-23
7-1	Blocking and tiedown of the M985E1, M983, or M977 vehicles on CONUS general-purpose flatcars	7-2
7-2	Blocking and tiedown details (fig 7-1)	7-3
7-3	Blocking and tiedown of the M927, M925, M942, M931, or M932 5-ton trucks on CONUS general purpose flatcar.....	7-6
7-4	Blocking and tiedown of the PATRIOT system van-type semitrailer-mounted components on CONUS general purpose flatcars.....	7-8
7-5	Forward support blocking assembly for van-type semitrailer-mounted components.....	7-9
7-6	Blocking and tiedown of the PATRIOT system trailer-mounted components on CONUS general-purpose flatcars.....	7-11
7-7	Forward support blocking assembly for trailer-mounted components.....	7-12
7-8	Blocking and tiedown of the M860A1 semitrailer with the ILS, outriggers, and generator, or with the RS removed and the outriggers in place on CONUS general-purpose flatcars	7-19
7-9	Blocking and tiedown of the RS on CONUS general-purpose flatcars	7-21
7-10	RS special blocking detail	7-22
7-11	Blocking and tiedown of the AMG on CONUS general purpose flatcars	7-24
7-12	Typical blocking and tiedown of the ECS, ICC, and CRG shelter-mounted components on CONUS general-purpose flatcars.....	7-29

List of Tables

<i>Table</i>	<i>Title</i>	<i>Page</i>
4-1	Tiedown Data for the 5-Ton Cargo Trucks in C-5 Aircraft (Fig. 4-1).....	4-2
4-2	Tiedown Data for the M983, M977, and M98E1 in C-5 Aircraft (Fig. 4-2)	4-2
4-3	Tiedown Data for the PATRIOT Trailer-Mounted EPUs in C-5 Aircraft (Fig. 4-3).....	4-8
4-4	Tiedown Data for the PATRIOT Semitrailer-Mounted RS or LS, Towed by an M983 Truck-Tractor, in C-5 Aircraft (Fig. 4-4)	4-11
4-5	Tiedown Data for the PATRIOT Semitrailer-Mounted MC (Btry), MC (Bn), or SRPT, Towed by an M931 or M932 Truck-Tractor, in C-5 Aircraft (Fig. 4-5)	4-12
4-6	Tiedown Data for the 5-Ton Cargo Trucks in C-141B Aircraft (Fig. 4-6)	4-16
4-7	Tiedown Data for the PATRIOT Engagement Control Station Mounted in a Shelter with Data Link Antenna Removed and Secured on Three Married 463L Pallets (HCU-6/E) (Fig. 4-7).....	4-16
4-8	Tiedown Data for the M983, M977, and M985E1 in C-141B Aircraft (Fig. 4-8).....	4-17
4-9	Tiedown Data for the M353 or M200A1 Trailer-Mounted EPUs in C-141B Aircraft (Fig. 4-9)	4-19
4-10	Tiedown Data for the Pallet/Platform-Loaded RS in C-141B Aircraft (Fig. 4-12).....	4-26

List of Tables-Continued

<i>Table</i>	<i>Title</i>	<i>Page</i>
4-11	Tiedown Data for the M860A1 Semitrailer in C-141B Aircraft (Fig. 4-13).....	4-27
4-12	Tiedown Data for the RS/LS Outriggers Secured on One 463L Pallet (Fig. 4-14)	4-27
4-13	Tiedown Data for the LS Electrical Power Unit on One 463L Pallet (Fig. 4-15)	4-27
5-1	Bill of Materials for Blocking and Tiedown of the M985E1, M983, or M977 on an M872 Semitrailer (Fig. 5-1) ...	5-4
5-2	Application of Materials for Blocking and Tiedown of the M985E1, M983, or M977 on an M872 Semitrailer (Fig. 5-1)	5-4
5-3	Bill of Materials for Blocking and Tiedown of the 5-Ton Truck or Truck-Tractor on an M872 Semitrailer (Figs. 5-2 through 5-4)	5-5
5-4	Application of Materials for Blocking and Tiedown of the 5-Ton Truck or Truck-Tractor on an M872 Semitrailer (Figs. 5-2 through 5-4).....	5-5
5-5	Bill of Materials for Blocking and Tiedown of the M860A1 on an M870 Semitrailer (Figs. 5-5 and 5-6)	5-11
5-6	Application of Materials for Blocking and Tiedown of the M860A1 on an M870 Semitrailer (Figs. 5-5 and 5-6) ..	5-11
5-7	Bill of Materials for Blocking and Tiedown of the PATRIOT Trailers on Semitrailer(s) (Figs. 5-7 and 5-8)	5-15
5-8	Application of Materials for Blocking and Tiedown of the PATRIOT Trailers on Semitrailer(s) (Figs. 5-7 and 5-8).....	5-15
5-9	Bill of Materials for Blocking and Tiedown of the PATRIOT Shelter-Mounted Items, Except RS, on Semitrailer(s) (Fig. 5-9)	5-16
5-10	Application of Materials for Blocking and Tiedown of the PATRIOT Shelter-Mounted Items, Except RS, on Semitrailer(s) (Fig. 5-9)	5-16
5-11	Bill of Materials for Blocking and Tiedown of the PATRIOT RS on Semitrailer(s) (Fig. 5-10)	5-20
5-12	Application of Materials for Blocking and Tiedown of the PATRIOT RS on Semitrailer(s) (Fig. 5-10).....	5-20
5-13	Bill of Materials for Blocking and Tiedown of the PATRIOT Platform- or Base-Mounted AMG and EPP on M269A1 or M270A1 Semitrailer(s) (Fig. 5-11)	5-21
5-14	Application of Materials for Blocking and Tiedown of the PATRIOT Platform- or Base-Mounted AMG and EPP on M-269A1 or M270A1 Semitrailer(s) (Fig. 5-11).....	5-21
6-1	Bill of Materials for Blocking and Tiedown of the M985E1, M983, and M977 Vehicles in General Cargo Vessel (Fig. 6-9)	6-16
6-2	Application of Materials for Blocking and Tiedown of M985E1, M983, M977 Vehicles in General Cargo Vessel (Fig. 6-9)	6-16
6-3	Bill of Materials for Blocking and Tiedown of a Typical 5-Ton, 6x6 M800- or M939-Series Truck in the Hold of a General Cargo Vessel (Fig. 6-10).....	6-16
6-4	Application of Materials for Blocking and Tiedown of a Typical 5-Ton, 6x6 M800- or M939-Series Truck in the Hold of a General Cargo Vessel (Fig. 6-10)	6-17
6-5	Bill of Materials for Blocking and Tiedown of the PATRIOT M860A1-Mounted Components in a General Cargo Vessel (Fig. 6-11)	6-17
6-6	Application of Materials for Blocking and Tiedown of the PATRIOT M860A1-Mounted Components in a General Cargo Vessel (Fig. 6-11).....	6-17
6-7	6-17 of Materials for Blocking and Tiedown of the PATRIOT Trailer-Mounted Components in a General Cargo Vessel (Fig. 6-12)	6-18
6-8	Application of Materials for Blocking and Tiedown of the PATRIOT Trailer-Mounted Components in a General Cargo Vessel (Fig. 6-12)	6-18
6-9	Bill of Materials for typical Blocking and Tiedown of a Two-Wheel Semitrailer in the Hold of a General Cargo Vessel (Fig. 6-13).....	6-18
6-10	Application of Materials for typical Blocking and Tiedown of a Two-Wheel Semitrailer in the Hold of a General Cargo Vessel (Fig. 6-13)	6-19
7-1	Bill of Materials for Blocking and Tiedown of the M985E1, M983, or M977 Trucks on CONUS General-Purpose Flatcars (Figs. 7-1 and 7-2)	7-4
7-2	Application of Materials for Blocking and Tiedown of the M985E1, M983, or M977 Trucks on CONUS Flatcars (Figs. 7-1 and 7-2).....	7-4
7-3	Bill of Materials for typical Blocking and Tiedown of the 5-Ton Trucks and Truck-Tractors Used in the PATRIOT Missile System on CONUS General-Purpose Flatcars (Figs. 7-2 and 7-3)	7-13
7-4	Application of Materials for Typical Blocking and Tiedown of 5-Ton Trucks and Truck-Tractors Used in the PATRIOT Missile System on CONUS General-Purpose Flatcars (Figs. 7-2 and 7-3)	7-13
7-5	Bill of Materials for Blocking and Tiedown of the PATRIOT System Van-Type Semitrailer-Mounted Components on CONUS General-Purpose Flatcars (Figs. 7-4 and 7-5).....	7-14
7-6	Application of Materials for Typical Blocking and Tiedown of PATRIOT Van-Type Semitrailer-Mounted Components on CONUS General-Purpose Flatcars (Figs. 7-4, 7-4, and 7-5).....	7-15
7-7	Bill of Materials for Blocking and Tiedown of the PATRIOT System Trailer-Mounted Components on CONUS General-Purpose Flatcars (Figs. 7-6 and 7-7).....	7-16
7-8	Application of Materials for Blocking and Tiedown of the PATRIOT System Trailer-Mounted Components on CONUS General-Purpose Flatcars (Figs. 7-2, 7-6, and 7-7)	7-16

List of Tables-Continued

<i>Table</i>	<i>Title</i>	<i>Page</i>
7-9	Bill of Materials for Blocking and Tiedown of the M860A1 Semitrailer with the LS, Outriggers, and Generator, or with the RS Removed and the Outriggers in Place on CONUS General-Purpose Flatcars (Figs. 7-2, and 7-8)	7-25
7-10	Application of Materials for Blocking and Tiedown of the M860A1 Semitrailer with the LS, Outriggers, and Generator, or with the RS Removed and the Outriggers in Place on CONUS General-Purpose Flatcars (Figs. 7-2, and 7-8)	7-25
7-11	Application of Materials for Blocking and Tiedown of the RS on CONUS General-Purpose Flatcars (Fig. 7-2 and 7-9, and 7-10)	7-26
7-12	Application of Materials for Blocking and Tiedown of the RS on CONUS General-Purpose Flatcars (Figs. 7-2, 7-9, and 7-10)	7-27
7-13	Bill of Materials for Blocking and Tiedown of the AMG on CONUS General-Purpose Flatcars (Fig. 7-2 and 7-11)	7-27
7-14	Application of Materials for Blocking and Tiedown of the AMG on CONUS General-Purpose Flatcars (Fig. 7-2 and 7-11)	7-28
7-15	Bill of Materials for Typical Blocking and Tiedown of the ECS, ICC, and CRG Shelter-Mounted Components on CONUS General-Purpose Flatcars (Figs. 7-2 and 7-12)	7-30
7-16	Application of Materials for Typical Blocking and Tiedown of the ECS, ICC, and CRG Shelter-Mounted Components on CONUS General-Purpose Flatcars (Figs. 7-2 and 7-12)	7-30
7-17	Restraint Required on Cushioned-Draft Railcars	7-31

CHAPTER 1 INTRODUCTION

1-1. Purpose and Scope

a. This manual provides transportability guidance for logistical handling and movement of the Phased Array Tracking to Intercept of Target (PATRIOT) missile system components. It contains information considered appropriate for safe transport of the system components. Included are technical data, as well as safety considerations, which will be useful in planning for worldwide movement by the various transport modes. Where appropriate, metric equivalents appear in parentheses after the dimensions or other measurements.

b. This manual is for transportation officers and other personnel responsible for moving the PATRIOT missile system components or for providing transportation services.

1-2. Safety

Precautionary measures required during movement of the PATRIOT missile system are in chapter 3.

1-3. Definitions of Warnings, Cautions, and Notes

Throughout this manual, warnings, cautions, and notes emphasize important or critical guidance. They are used for the following conditions:

a. *Warning.* Instructions that, if not followed, could result in injury to or death of personnel.

b. *Caution.* Instructions that, if not strictly observed, could result in damage to or destruction of equipment.

c. *Note.* An operating procedure condition that must be emphasized.

1-4. Reporting of Recommendations and Comments

MTMCTEA welcomes comments and recommended changes for improving this manual. Users of this manual should prepare comments and recommendations on DA Form 2028 (Recommended Changes to DA Publications and Blank Forms) and forward to Commander, Military Traffic Management Command Transportation Engineering Agency, ATTN: MTTE-TRA, PO Box 6276, Newport News, VA 23606-0276. Address electrically transmitted messages to CDR MTMCTEA FT EUSTIS VA //MTTE-TRA//. This command will furnish a reply.

CHAPTER 2 TRANSPORTABILITY DATA

2-1. Scope

This chapter provides a general description and drawings of the PATRIOT missile system components. The drawings contain tabulated transportability characteristics that will assist in the planning and transport of the system components. These characteristics apply to the model number or national stock number shown.

2-2. Description and Transportability Drawings

a. *Radar Set (RS), AN/MPQ-53, Semitrailer Mounted, Towed by the M983 (Fig 2-1).* The operational RS uses the M983 heavy expanded mobility tactical truck (HEMTT) (fig 2-2) as the prime mover for the M860A1 semitrailer (fig 2-3). The M983 is a 10-ton, 8 x 8 truck-tractor. The M860A1 has outriggers at each of the four corners for leveling and stabilizing the RS. The outriggers are removed to reduce the height when required by the mode of shipment. The maximum reduced configuration of the RS is shown in figure 2-4.

GROSS WEIGHT = 77,615 LB (35 214 KG)

AXLE LOADS

- NO. 1 AXLE 11,202 LB (5 082 KG)
- NO. 2 AXLE 11,202 LB (5 082 KG)
- NO. 3 AXLE 11,003 LB (4 992 KG)
- NO. 4 AXLE 11,003 LB (4 992 KG)
- NO. 5 AXLE 16,603 LB (7 533 KG)
- NO. 6 AXLE 16,603 LB (7 533 KG)

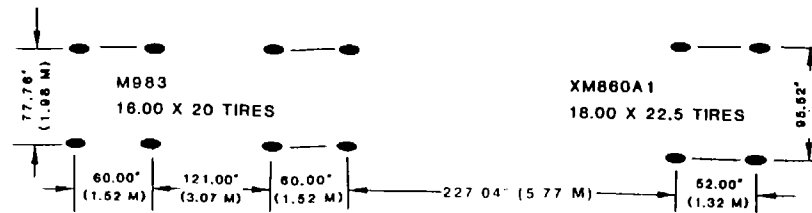

FOOTPRINT DATA

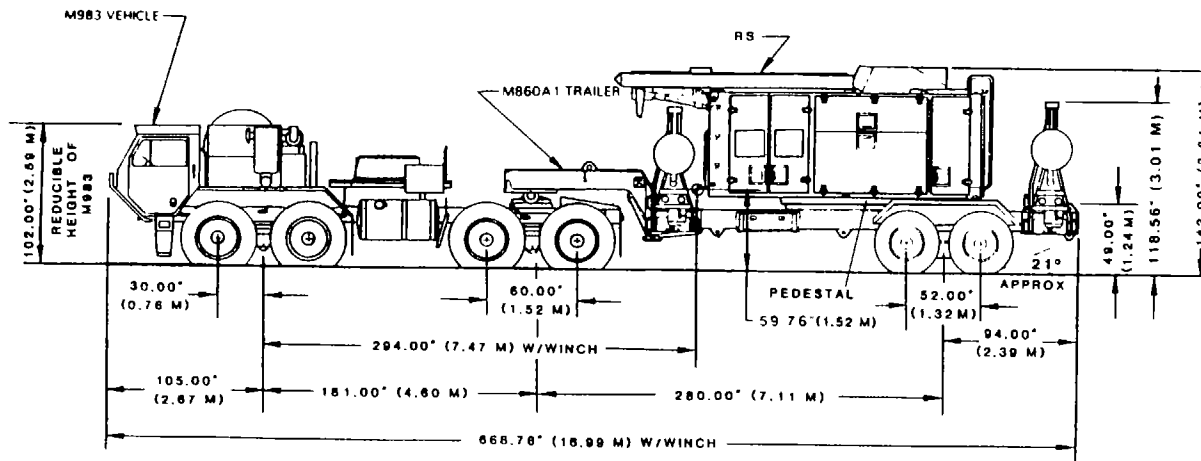

SIDE VIEW

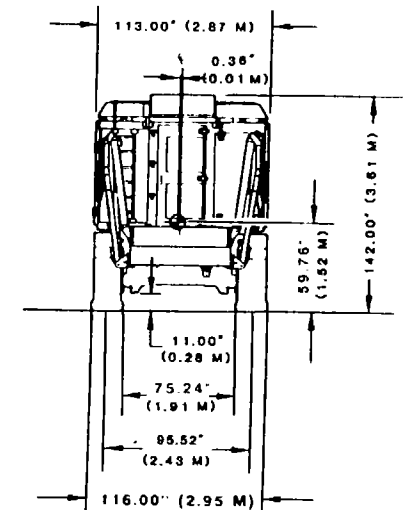

REAR VIEW

Figure 2-1. Radar set, AN/MPQ-53, semitrailer-mounted, towed by the M983 truck-tractor.

MSN	2320-01-097-0247
LIN	T88677
SPEED	61 MPH (98 KM/H)
RANGE	800 MI
FUEL	150 GAL (568 L) DIE
TURNING RADIUS	42.5 FT (12.95 M)
KING PIN	3.5 IN (0.09 M)
MIC	14
TIRES	16.00 R20 W/TUBE
FOOTPRINT	117.3 IN ²
@ MAX LOAD	240.3 IN ²
GROUND PRESSURE	
@ UNLOADED	23.6 PSI
@ MAX LOAD	46.0 PSI

CUBE:	
OPERATIONAL	3.180 FT ³ (90.01 M ³)
WITH MIRRORS AND SPARE TIRE REMOVED	2.090 FT ³ (59.14 M ³)
WITH MIRRORS, HAND BARS, AND SPARE TIRE REMOVED	1.967 FT ³ (55.66 M ³)

WEIGHT:	
CURB WEIGHT	32,150 LB (14,583 KG)

GROSS VEHICLE WEIGHT WITH KINGPIN LOAD	49,650 LB (22,521 KG)
--	-----------------------

AXLE LOAD (CURB WEIGHT):	
NO. 1 AXLE	10,900 LB (4,944 KG)
NO. 2 AXLE	10,900 LB (4,944 KG)
NO. 3 AXLE	5,175 LB (2,347 KG)
NO. 4 AXLE	5,175 LB (2,347 KG)

AXLE LOAD (GROSS VEHICLE WEIGHT):	
NO. 1 AXLE	11,400 LB (5,171 KG)
NO. 2 AXLE	11,400 LB (5,171 KG)
NO. 3 AXLE	13,425 LB (6,090 KG)
NO. 4 AXLE	13,425 LB (6,090 KG)

M983 CENTER OF GRAVITY		
	A (AFT OF CL 2ND AXLE)	B (ABOVE GROUND)
W/O CRANE	30 (0.76 M)	43 (1.09 M)
W/CRANE	36 (0.91 M)	49 (1.24 M)

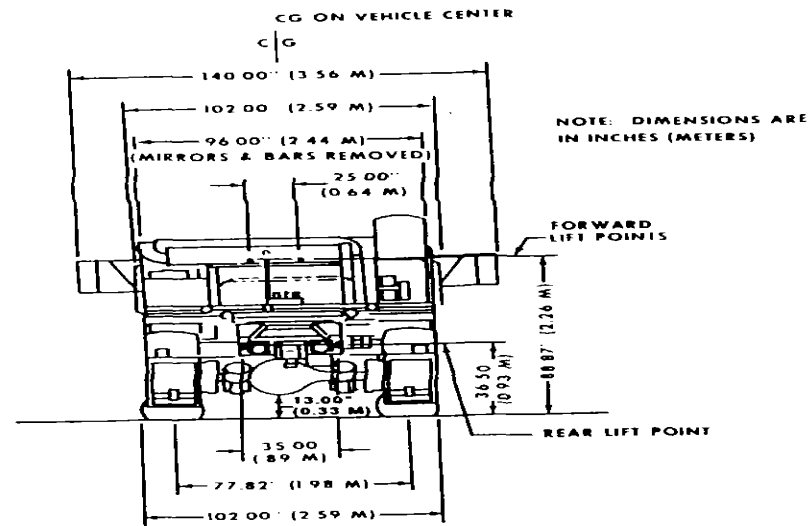

REAR VIEW

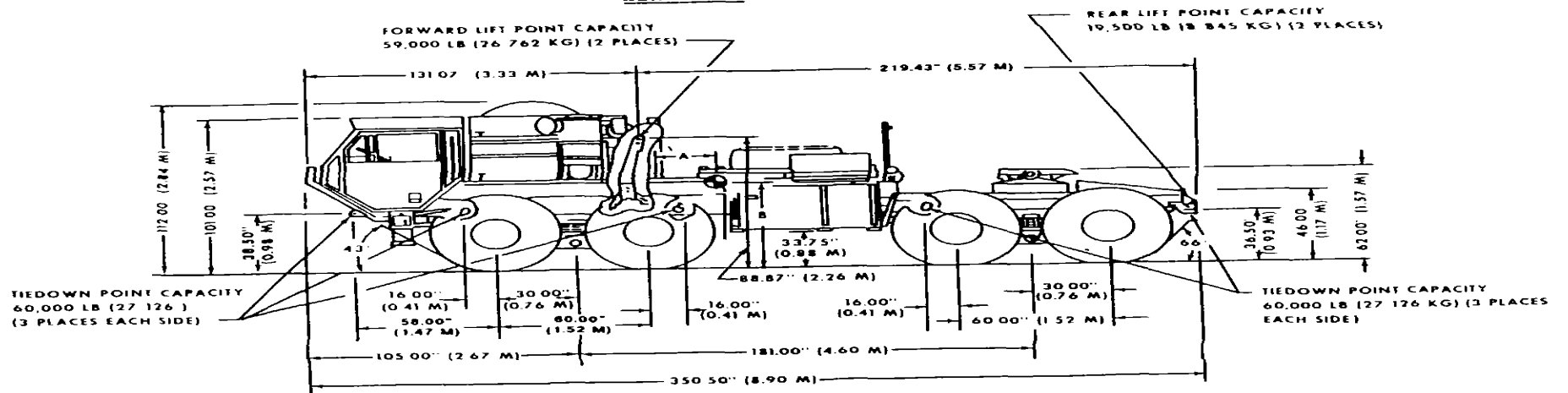

LEFT-SIDE VIEW

Figure 2-2. M983, 10-ton, 8 x 8 truck-tractor

A & E = LIFT CAPACITY 110,055 LB (49 930 KG)
 B,C,D,&F = TIEDOWN CAPACITY
 VERTICAL 95,700 LB (43 409 KG)
 LONGITUDINAL 191,400 LB (86 817 KG)
 LATERAL 71,775 LB (32 556 KG)

WEIGHTS IN POUND (KG)			
	OPERATIONAL	WO/RS SHELTER	WO OUTRIGGERS
CURB	45,460 (20 620)	23,080 (10 469)	19,684 (8 929)
KINGPIN	12,256 (5 559)	6,147 (2 788)	4,681 (2 123)
BOGIE	33,204 (15 061)	16,933 (7 681)	15,003 (6 805)
LANDING GEAR	16,866 (7 650)	8,563 (3 884)	6,633 (3 009)
BOGIE	28,544 (12 948)	14,517 (6 585)	12,587 (5 709)

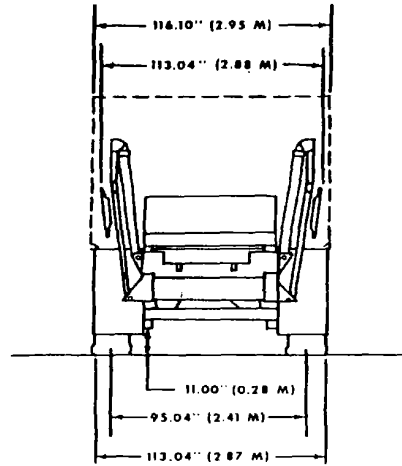

REAR VIEW

NSN: 1430-01-087-6330
 LIN: R18815
 KINGPIN: 3.5 IN (0.09 M)
 TIRES: 18 00x22.5 RADIAL
 INFLATION: 55 PSIG (379 KPA)
 FOOTPRINT: 144 IN² (0.09 M²)
 GROUND PRESSURE:
 W/RS 57.6 PSI
 WO RS 29.4 PSI
 AREA: 317.0 FT² (29.45 M²)
 CUBE:
 OPERATIONAL 3.850 FT³ (108.84 M³)
 WO/RS SHELTER 3.204 FT³ (90.69 M³)
 WO OUTRIGGERS 2.196 FT³ (62.15 M³)

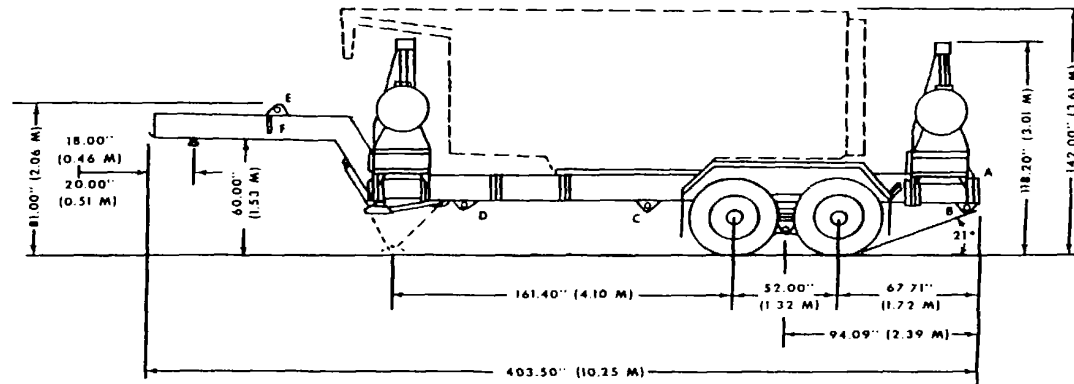

SIDE VIEW

Figure 2-3. RS M860A1 semitrailer, with outriggers in transport position.

NOTE 1: TIEDOWN CAPACITY:
 LONG 50,000 LB (22 680 KG)
 LAT 25,000 LB (11 340 KG)

NOTE 2: (A) TIEDOWN CAPACITY:
 VERT 41,150 LB (18 665 KG)
 LONG 43,820 LB (19 876 KG)
 (B) LIFT CAPACITY:
 VERT 26,535 LB (12 036 KG)
 LONG 19,418 LB (8 808 KG)

NOTE 3: LIFT CAPACITY:
 VERT 49,700 LB (22 543 KG)
 LAT 27,600 LB (12 519 KG)

NOTE 4: TIEDOWN CAPACITY:
 VERT 38,361 LB (17 400 KG)
 LONG 25,256 LB (11 456 KG)
 LAT 3,881 LB (1 760 KG)

GROSS WEIGHT = 22,760 LB (10 327)

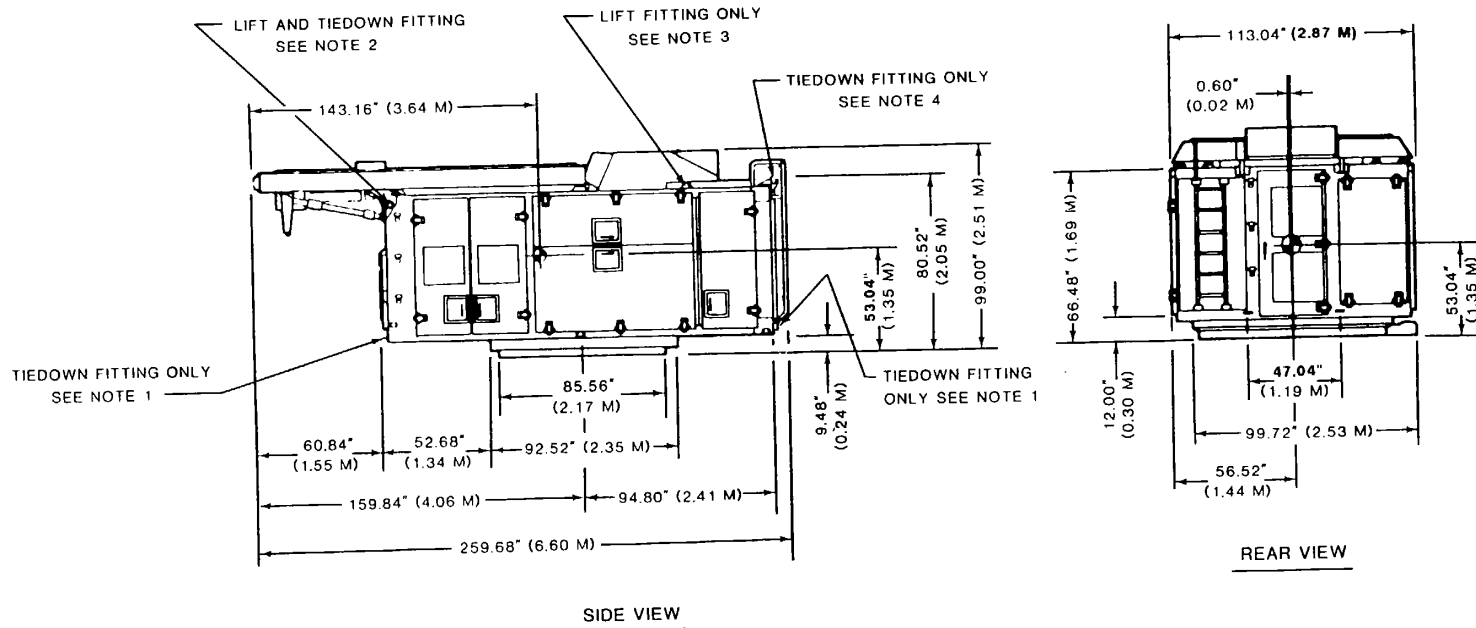
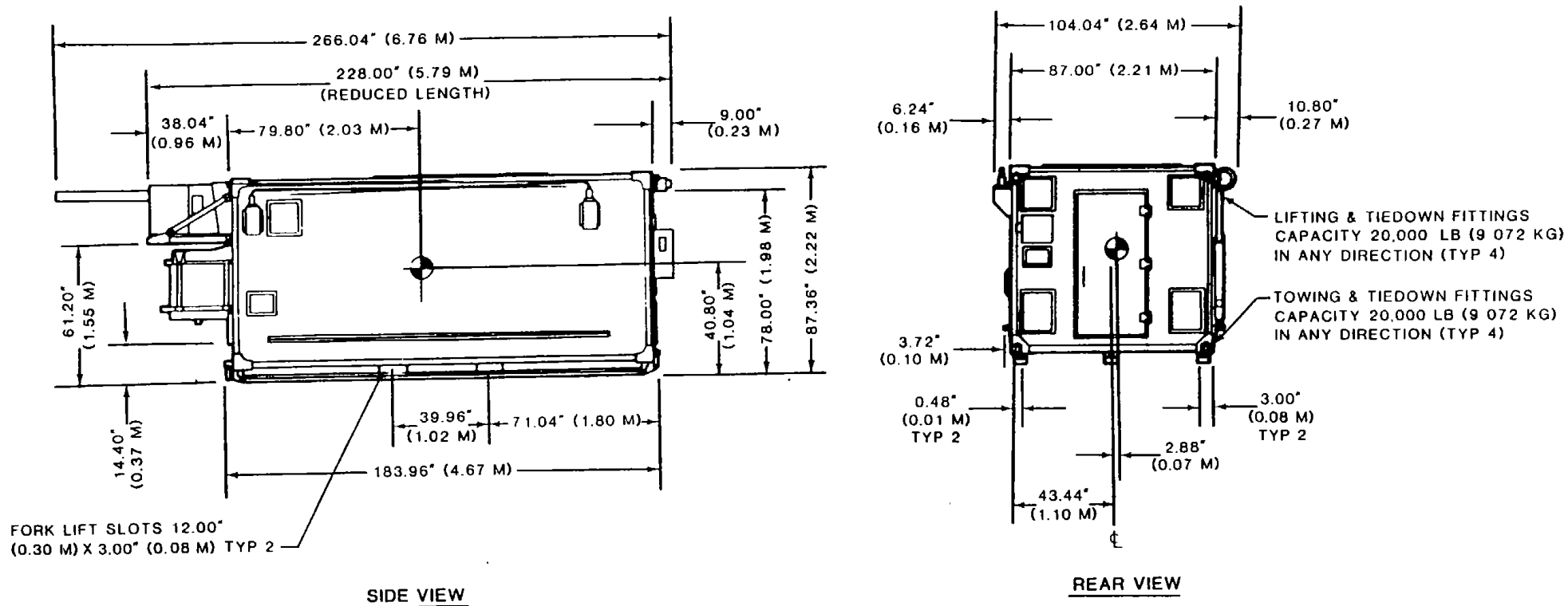

Figure 2-4. Radar set, AN/MPQ-53, removed from semitrailer

b. Engagement Control Station (ECS) AN/MSQ104. The ECS is shelter mounted (fig 2-5). The shelter is transported by an M927. This 5-ton, 6 x 6 truck is shown in figure 2-6. The shelter width is reducible to 87 inches by removing the whip antenna

mounts and the telescoping VHF digital link antenna. Shipments of the ECS with crypto units installed require constant surveillance because crypto units are classified as secret.



NOTE: GROSS WEIGHT = 12,410 LB (5 631 KG)

Figure 2-5. Shelter-mounted engagement control station.

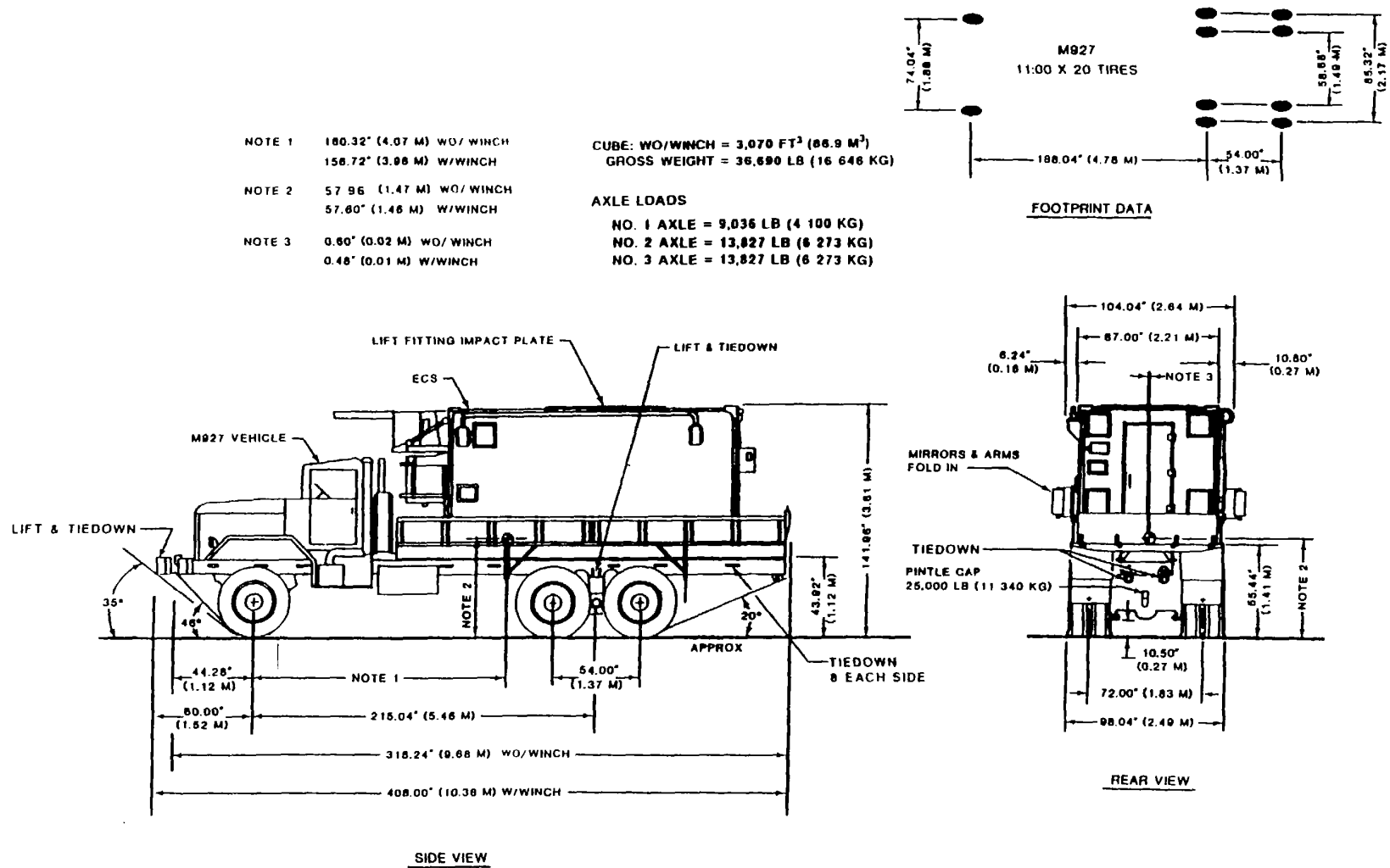
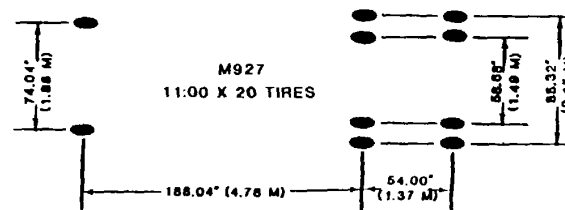

Figure 2-6. Engagement control station on an M927

c. *Information and Coordination Central (ICC)*. The ICC is a shelter mounted on an M927, as shown in figure 2-7. The ICC removed from the truck is shown in figure 2-8. The ICC is classified as secret when shipped

with crypto units installed. Under these conditions, shipment requires constant surveillance.

CUBE: WO/WINCH 3070 FT³ (86.9 M³)
 GROSS WEIGHT 35,040 LB (15 898 KG)
 AXLE LOADS
 NO. 1 AXLE 9,072 LB (4 116 KG)
 NO. 2 AXLE 12,984 LB (5 891 KG)
 NO. 3 AXLE 12,984 LB (5 891 KG)



FOOTPRINT DATA

NOTE 1 159.12' (4.04 M) WO/WINCH
 155.62' (3.95 M) W/WINCH
 NOTE 2 58.88' (1.44 M) WO/WINCH
 58.64' (1.44 M) W/WINCH

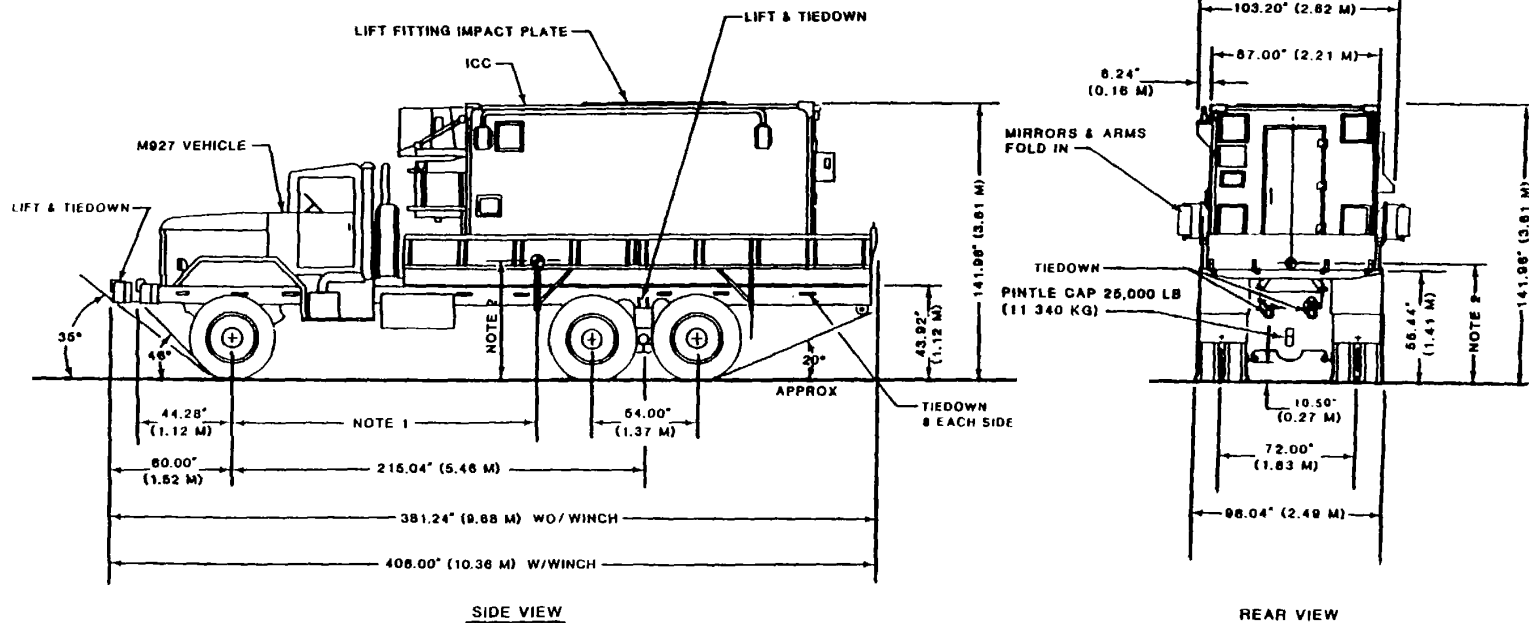
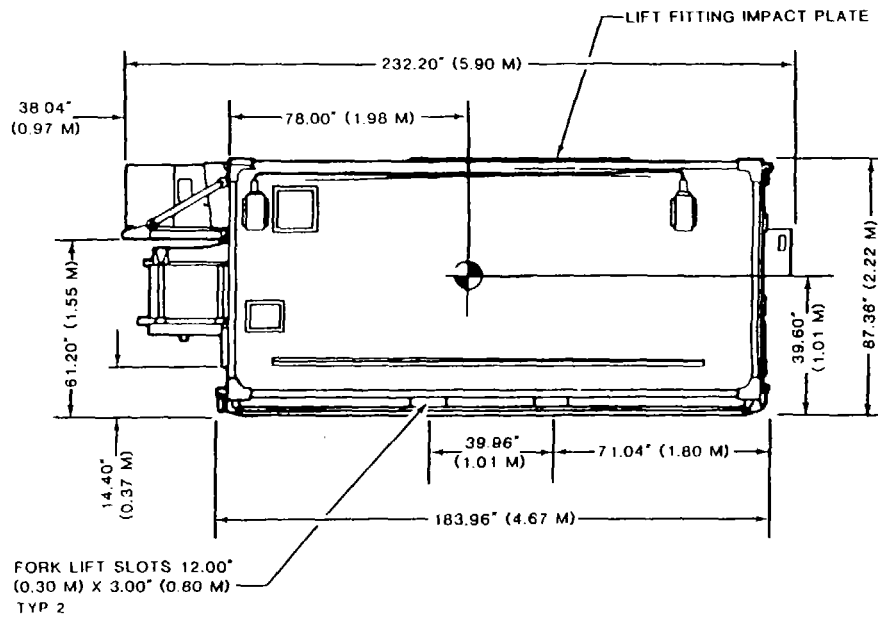
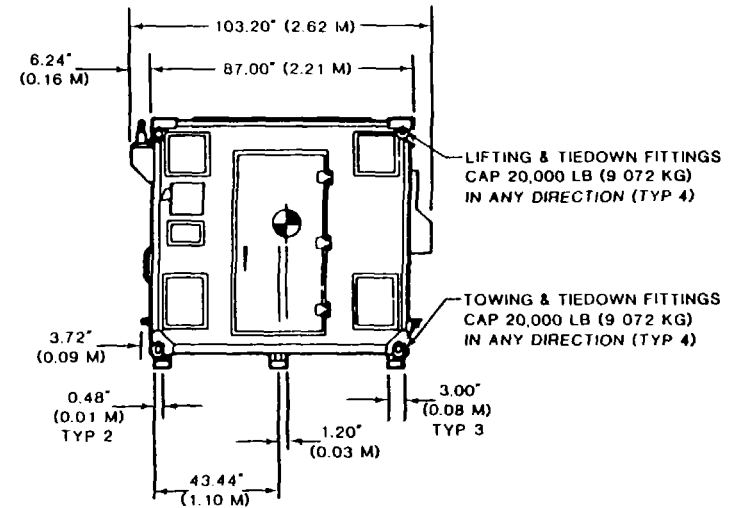

Figure 2-7. Information and coordination central mounted on an M927
 2-10



SIDE VIEW



REAR VIEW

NOTE: GROSS WEIGHT = 10,760 LB (4 882 KG)

Figure 2-8. Shelter-mounted information and coordination central.

d. Launching Station (LS), Semitrailer-Mounted, M901. The PATRIOT missile system uses the M983 HEMTT as the prime mover for the LS, as shown in figure 2-9. The M983, a 10-ton, 8 x 8 truck-tractor, is shown in figure 2-2. The LS mounted on the M860A1 semitrailer is shown in figure 2-10. The M860A1 has

outriggers at each of the four corners for leveling and stability. Electrical power is provided by a 15-kW diesel-powered generator, with a 15-gallon fuel tank, mounted on the gooseneck of the semitrailer. Reduced shipping configurations are shown in figures 2-11 and 2-12.

GROSS WEIGHT = 65,830 LB (29 860 KG)

AXLE LOADS

- NO. 1 AXLE 10,981 LB (4 981 KG)
- NO. 2 AXLE 10,981 LB (4 981 KG)
- NO. 3 AXLE 10,551 LB (4 786 KG)
- NO. 4 AXLE 10,551 LB (4 786 KG)
- NO. 5 AXLE 11,383 LB (5 163 KG)
- NO. 6 AXLE 11,383 LB (5 163 KG)

TIRE PRINT 109 IN²
GROUND PRESSURE 52.2 PSI

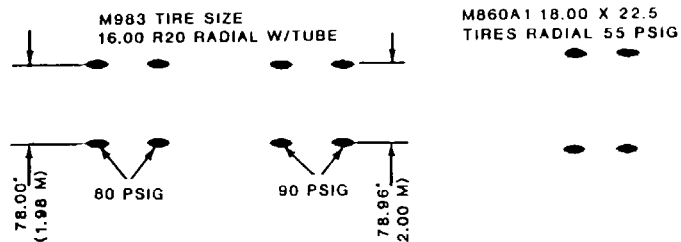

FOOTPRINT DATA

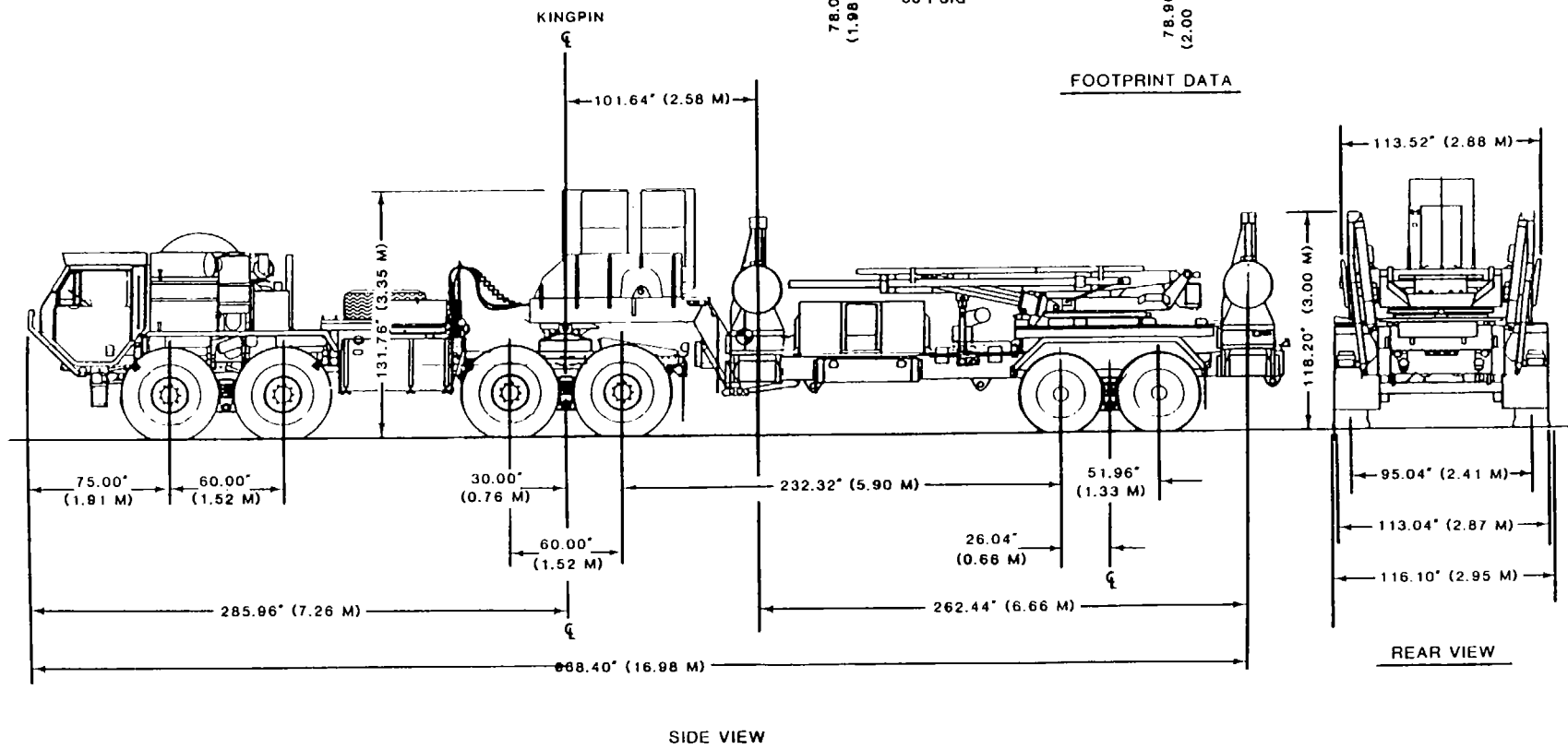

SIDE VIEW

REAR VIEW

Figure 2-9. Launching station M901, semitrailer-mounted, towed by an M983 truck-trailer
2-13

NSN 1440-01-087-9844
LIN: N/A

WEIGHTS IN POUNDS (KG)			
	OPERATIONAL	W/O GENERATOR GENERATOR	W/O GEN AND OUTRIGGERS
CURB	32,930 (14 937)	28,120 (12 765)	24,724 (11 216)
KINGPIN	10,164 (4 610)	7,134 (3 238)	6,372 (2 890)
BOGIE	22,768 (10 327)	19,858 (9 007)	19,888 (9 021)
LANDING GEAR	15,863 (6 267)	10,735 (4 892)	8,827 (4 458)
BOGIE	17,268 (7 833)	17,335 (7 863)	14,888 (6 758)

LIFT AND TIEDOWN CAPACITY IN POUNDS (KG)						
POINTS (TYP BOTH SIDES)	FWD	AFT	INBD	OUTBD	UP	DOWN
a	43,900 (19 900)		24,400 (11 100)		50,300 (22 800)	
b		62,000 (28 100)		35,800 (16 200)		29,000 (13 100)
c	62,000 (28 100)			35,800 (16 200)		29,000 (13 100)
d	62,000 (28 100)	62,000 (28 100)		35,800 (16 200)		29,000 (13 100)
e		43,900 (19 900)	24,400 (11 100)		50,300 (22 800)	
f	36,800 (16 200)	36,800 (16 200)		62,000 (28 100)		29,000 (13 100)

	W/GEN & OUTRIGGERS	W/O GEN	W/O GEN & OUTRIGGERS
A	54.00" (1.37 M)	49.00" (1.25 M)	48.20" (1.18 M)
B	200.30" (5.08 M)	190.90" (4.85 M)	214.80" (5.45 M)

AREA: 325 FT² (30.18 M²)

CUBE: OPERATIONAL: 3574 FT³ (101.43 M³)
 WO/ GENERATOR: 3230 FT³ (91.40 M³)
 WO/ GENERATOR
 AND OUTRIGGERS: 2462 FT³ (69.68 M³)

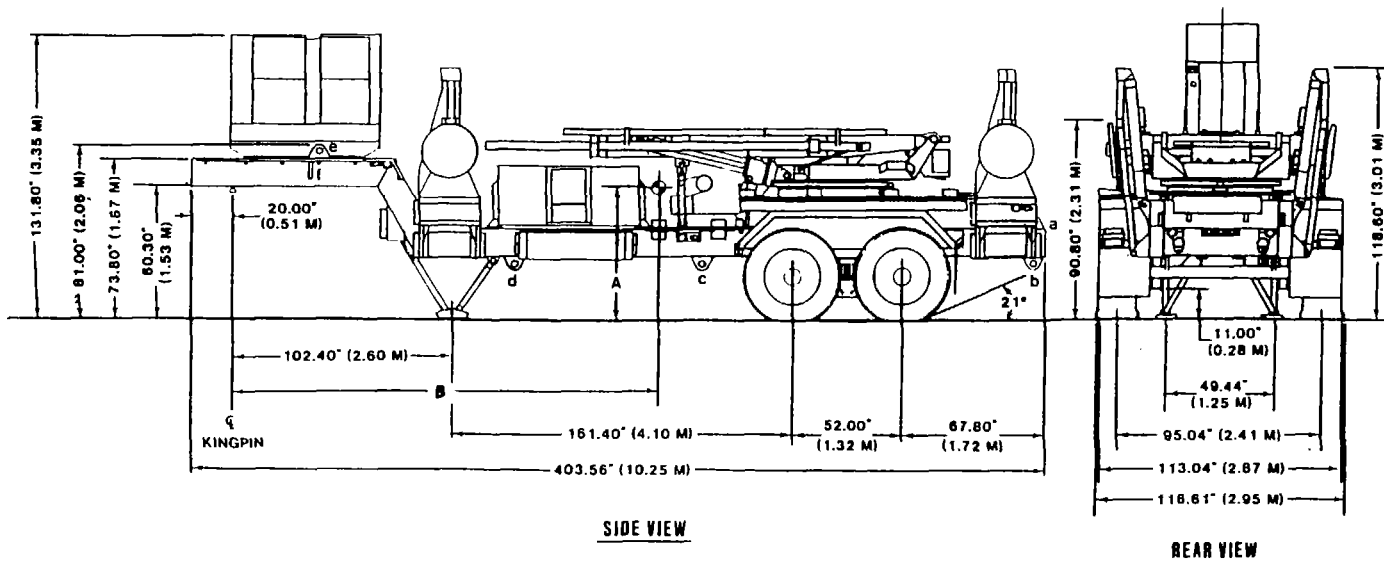
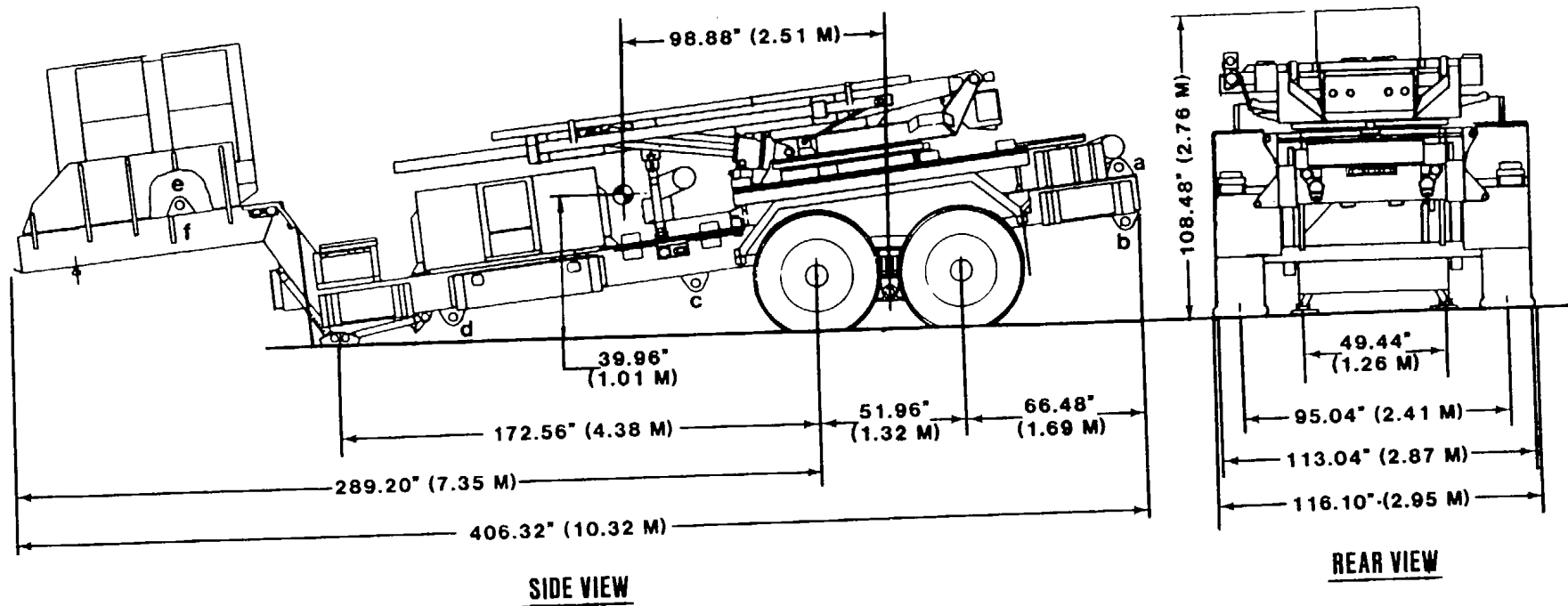
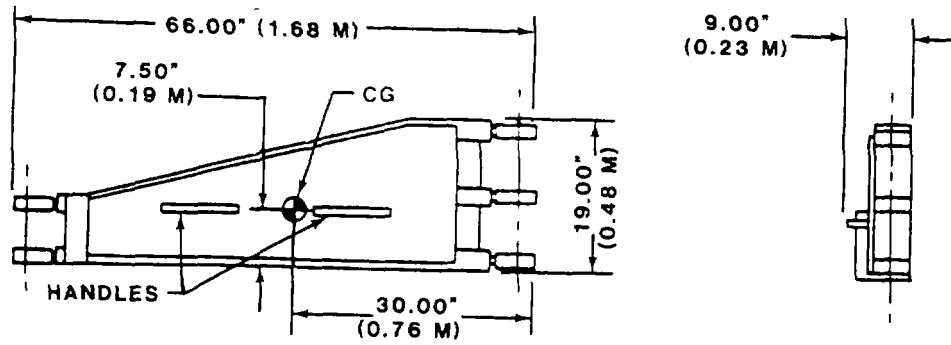

Figure 2-10. Launching station M901, mounted on an M860A1 semitrailer, with generator and outriggers in place.



NOTE: GROSS WEIGHT = 32,930 LB (14 937 KG)

Figure 2-11. Launching station M901, mounted on an M860A1 semitrailer, with landing gear retracted and rear outriggers removed.



WT: 275 LB (124.72 KG)
 VOLUME: 7.75 FT³ (0.22 M³)

UPPER ARM

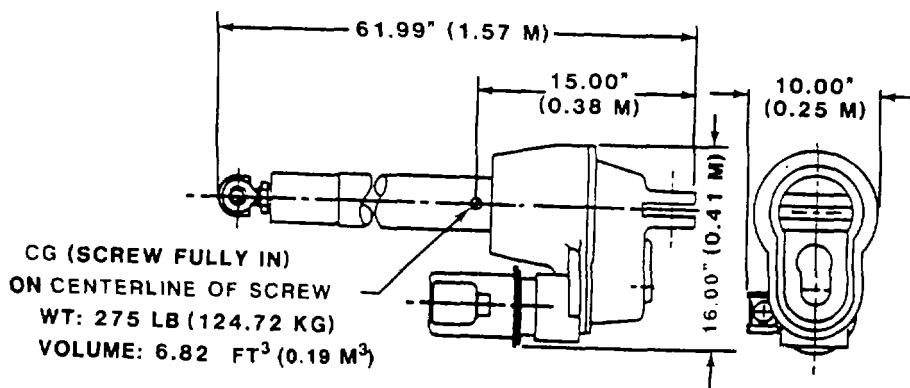

CG (SCREW FULLY IN)
 ON CENTERLINE OF SCREW
 WT: 275 LB (124.72 KG)
 VOLUME: 6.82 FT³ (0.19 M³)

BALL SCREW ACTUATOR ASSY

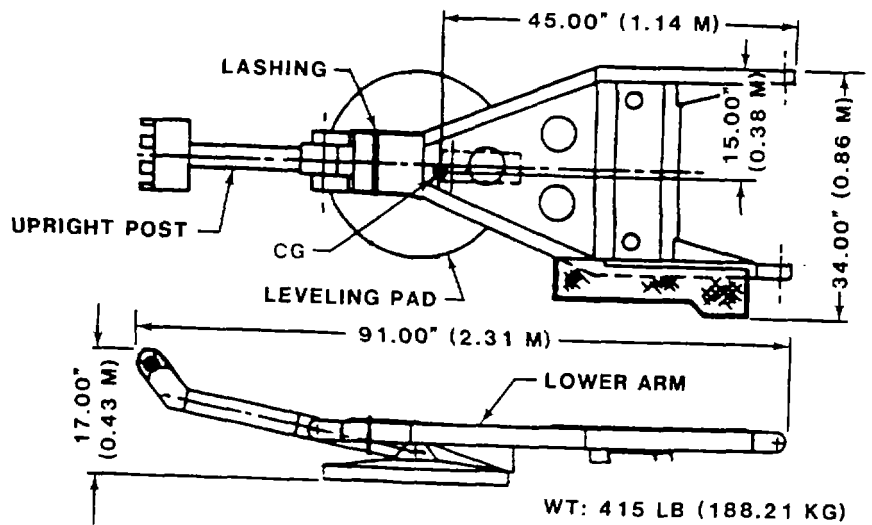

WT: 415 LB (188.21 KG)
 VOLUME: 33.54 FT³ (0.95 M³)

LOWER ARM ASSY

Figure 2-12. Outriggers removed from the LS M860A1 semitrailer.

e. *Large Repair Parts Transporter (LRPT)*. The LRPT is an Mp77 HEMTT. This 10-ton, 8 x 8 cargo truck is shown in figure 2-13.

SPEED:	41 MPH (98 KM/H)	
RANGE:	400 MILES	
FUEL:	150 GAL (568 L) DIESEL	
TURNING RADIUS:	47 FT (14.33 M)	
MLC:	16 AND 17	
TIRES:	16-00 R20 W/TUBE	
FOOTPRINT:	117.30 M ² (0.08 M ²)	
@ MAX LOAD:	240.30 M ² (0.16 M ²)	
GROUND PRESSURE:		
UNLOADED:	41.3 PSI (285 KPA)	
@ MAX LOAD:	64.8 PSI (447 KPA)	
	NSN 2320-01-097-0260	NSN 2320-01-097-0261
CUBE:	M977	M985E1
OPERATIONAL:	3634 FT ³ (102.85 M ³)	3816 FT ³ (107.98 M ³)
WITH MIRRORS AND SPARE TIRE REMOVED:	2388 FT ³ (67.56 M ³)	2507 FT ³ (70.95 M ³)
AND SPARE TIRE REMOVED:	2247 FT ³ (63.60 M ³)	2360 FT ³ (66.77 M ³)
WEIGHT:		
CURB WEIGHT:	38,800 LB (17,400 KG)	39,650 LB (17,985 KG)
GROSS VEHICLE WEIGHT:	59,700 LB (27,080 KG)	62,100 LB (28,169 KG)
AXLE LOAD (CURB WEIGHT):		
NO.1 AXLE:	10,425 LB (4,820 KG)	10,475 LB (4,751 KG)
NO.2 AXLE:	10,425 LB (4,820 KG)	10,475 LB (4,751 KG)
NO.3 AXLE:	8,775 LB (3,980 KG)	9,350 LB (4,241 KG)
NO.4 AXLE:	8,775 LB (3,980 KG)	9,350 LB (4,241 KG)
AXLE LOAD (GROSS VEHICLE WEIGHT):		
NO.1 AXLE:	14,000 LB (6,350 KG)	13,575 LB (6,158 KG)
NO.2 AXLE:	14,000 LB (6,350 KG)	13,575 LB (6,158 KG)
NO.3 AXLE:	15,850 LB (7,190 KG)	17,475 LB (7,927 KG)
NO.4 AXLE:	15,850 LB (7,190 KG)	17,475 LB (7,927 KG)
CRANE CAPACITY:		
AT 9 FEET:	4,500 LB (2,041 KG)	
AT 19 FEET:	2,500 LB (1,134 KG)	
AT 14.5 FEET:		5,400 LB (2,449 KG)

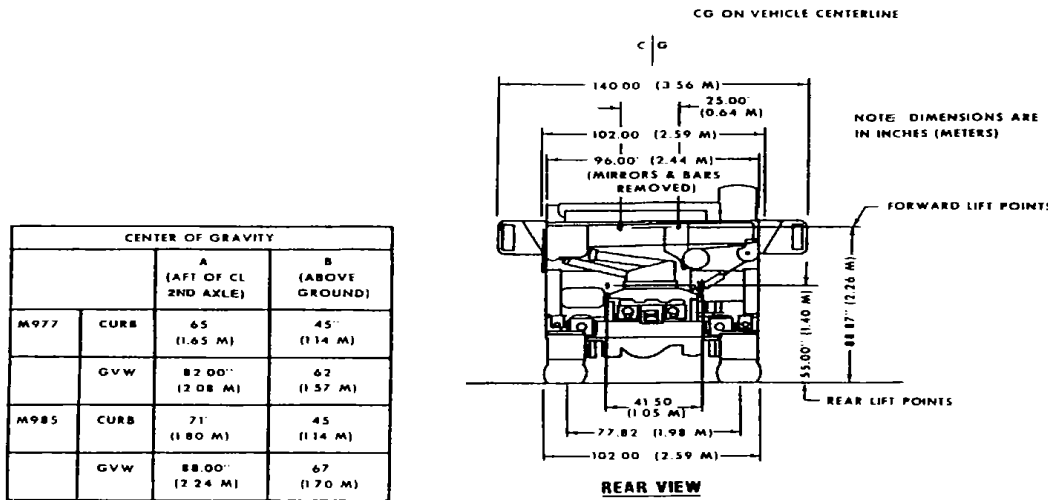

CENTER OF GRAVITY			
		A (AFT OF CL 2ND AXLE)	B (ABOVE GROUND)
M977	CURB	65 (1.65 M)	45' (1.14 M)
	GVW	82.00" (2.08 M)	62 (1.57 M)
M985	CURB	71' (1.80 M)	45 (1.14 M)
	GVW	88.00" (2.24 M)	67 (1.70 M)

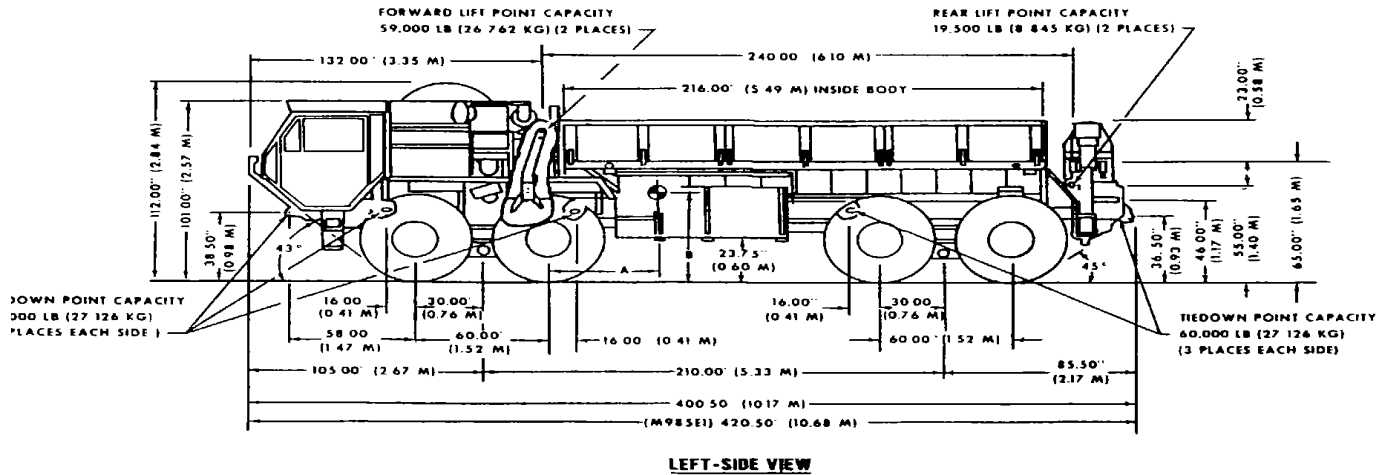

Figure 2-13. Large repair parts transporter, M977.

f. Guided Missile Transporter (GMT). The GMT is the M985E1 HEMTT (a 10-ton, 8 x 8 cargo truck) with mounts for missile canisters and an HIAB 8108 crane. It is similar to the M977 (fig 213), with a frame extension and cargo bed extension. Unlike the M977, the M985E1 HEMTT has no permanent rear lifting provision.

g. Maintenance Centers, Battalion AN/TSM-163, Battery AN/TSM-164, and Small Repair Parts Transporter M1032. The maintenance centers and small repair parts transporter are M373A2 semitrailers towed by M932, 5-ton truck tractors, as shown in figures 2-14 through 2-16.

TIRES: 9.00 X 20 TUBE TYPE
 INFLATION:55 PSIG (345 KPA)

WEIGHTS IN POUNDS (KG)		
	CURB WEIGHT	GROSS VEHICLE WEIGHT
KING PIN AXLE	3,390 (1538 KG)	8,890 (4033 KG)
	6,040 (2740 KG)	12,540 (5688 KG)
	9,430	21,430
LANDING GEAR AXLE	4,430 (2009 KG)	10,072 (4569 KG)
	5,000 (2268 KG)	11,358 (5152 KG)
	9,430	21,430

NSN 4935-01-136-0233, AN/TSM-164; AREA, 275 FT² (25.55 M²); CUBE, 3144 FT³ (89.98 M³)
 NSN 4935-01-134-8713, AN/TSM-163; AREA, 275 FT² (25.55 M²); CUBE, 3144 FT³ (89.98 M³)
 NSN 2330-01-130-7980, SRPT, M1032; AREA, 262 FT² (24.34 M²); CUBE, 2986 FT³ (84.50 M³)

CENTER OF GRAVITY DIMENSIONS			
A	B	C	
BATTALION MAINTENANCE CENTER AN/TSM 164	69.35" (1.76 M)	132.28" (3.36 M)	0.31" (0.01 M)
BATTERY MAINTENANCE CENTER AN/TSM 163	69.15" (1.75 M)	133.16" (3.38 M)	0.16" (0.01 M)
SMALL REPAIR PARTS TRANSPORTER M1032	73.10" (1.86 M)	143.00" (3.63 M)	0.82" (0.02 M)

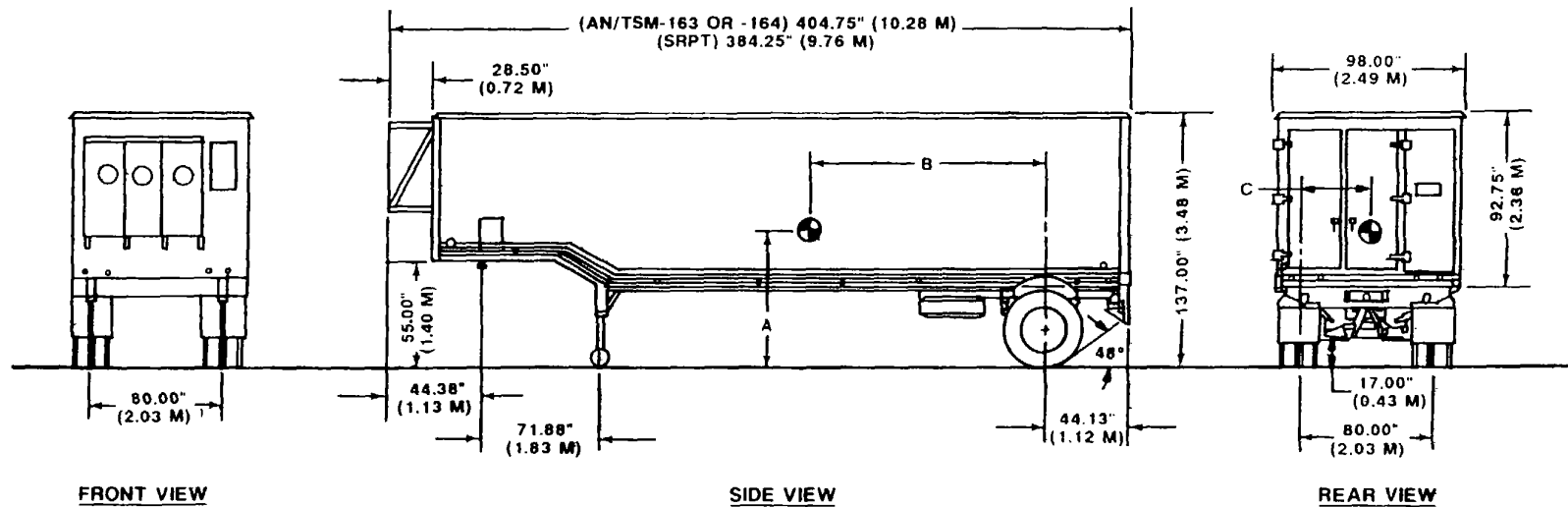

Figure 2-14. Battalion maintenance center AN/TSM-163, or small repair parts transporter M1032, mounted in a modified M373A2 semitrailer van

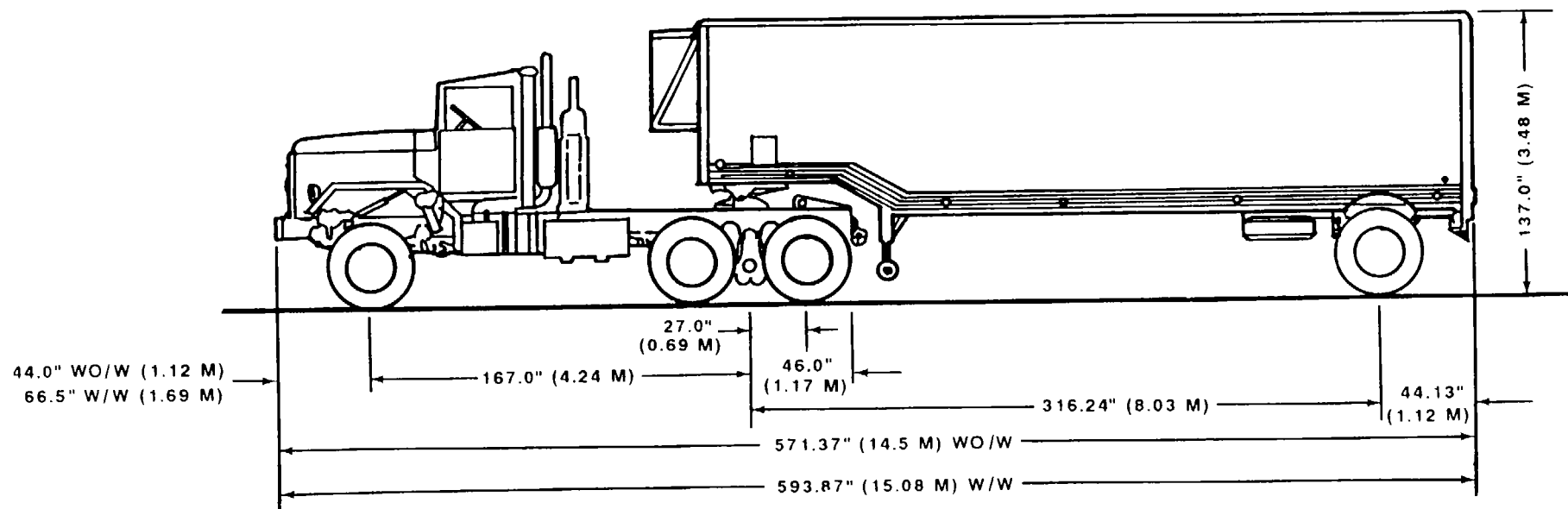

Figure 2-15. Battalion maintenance center AN/TSM-164, battery maintenance center AN/TSM-163, or small repair parts transporter M1032, semitrailer van mounted and towed by an M932.

WEIGHT IN POUNDS (KG)	
CURB WEIGHT	21,610 (9 802)
GROSS VEHICLE WEIGHT	36,610 (16 606)
AXLE LOAD (CURB)	
NO. 1	10,870 (4 930)
NO. 2	5,370 (2 436)
NO. 3	5,370 (2 436)
AXLE LOAD (GVW)	
NO. 1	11,245 (5 101)
NO. 2	12,683 (5 753)
NO. 3	12,683 (5 753)

NSN 2320-01-047-8752
LIN X59463

CUBE: OPERATIONAL	2,373 FT ³ (67.16 M ³)
W/MIRRORS REMOVED	1,922 FT ³ (54.39 M ³)
W/MIRRORS AND CAB FOLDED	1,482 FT ³ (41.94 M ³)
AREA: OPERATIONAL W/MIRRORS FOLDED	194 FT ² (17.99 M ²)
MAXIMUM SPEED: 55 MPH (88 KM/H)	FUEL TANK CAPACITY: 116 GAL (439 L)
MAXIMUM RANGE: 460 MILES (740 KM)	FUEL: DIESEL
TIRES: 80 PSI (FRONT) 50 PSI (REAR)	

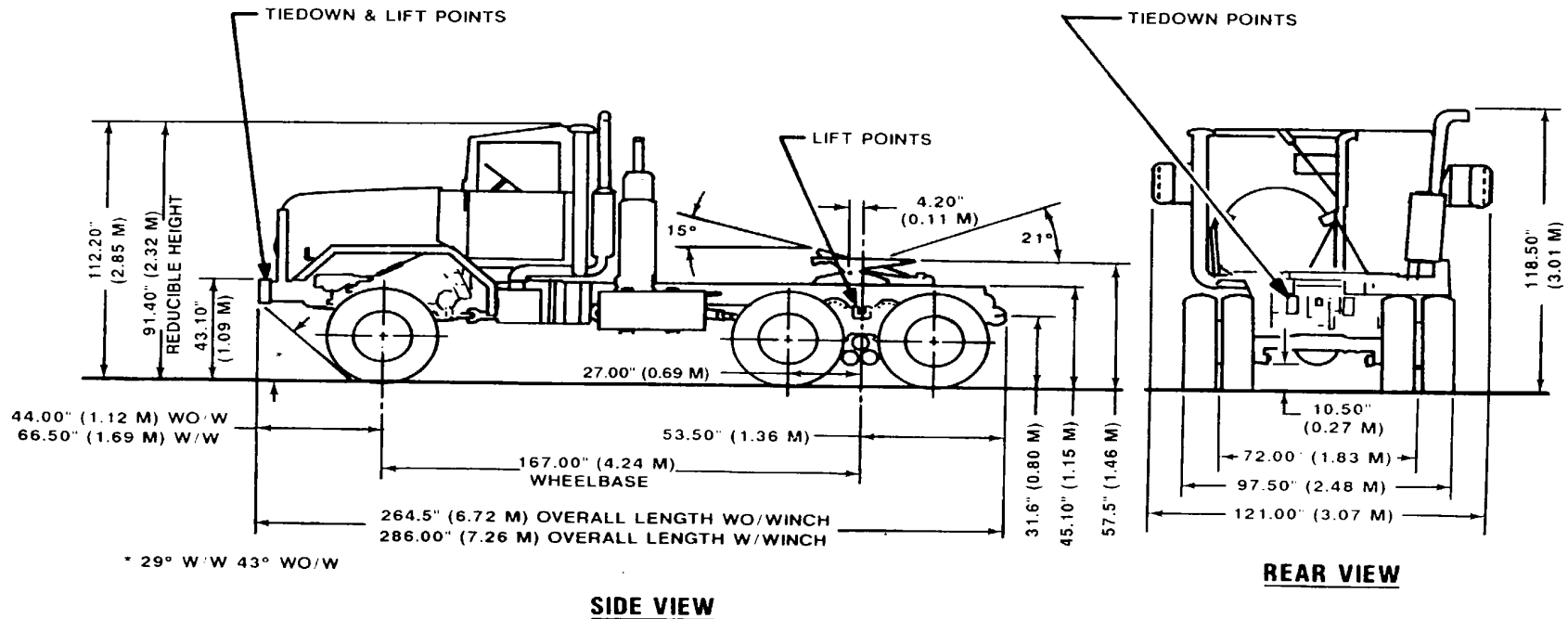
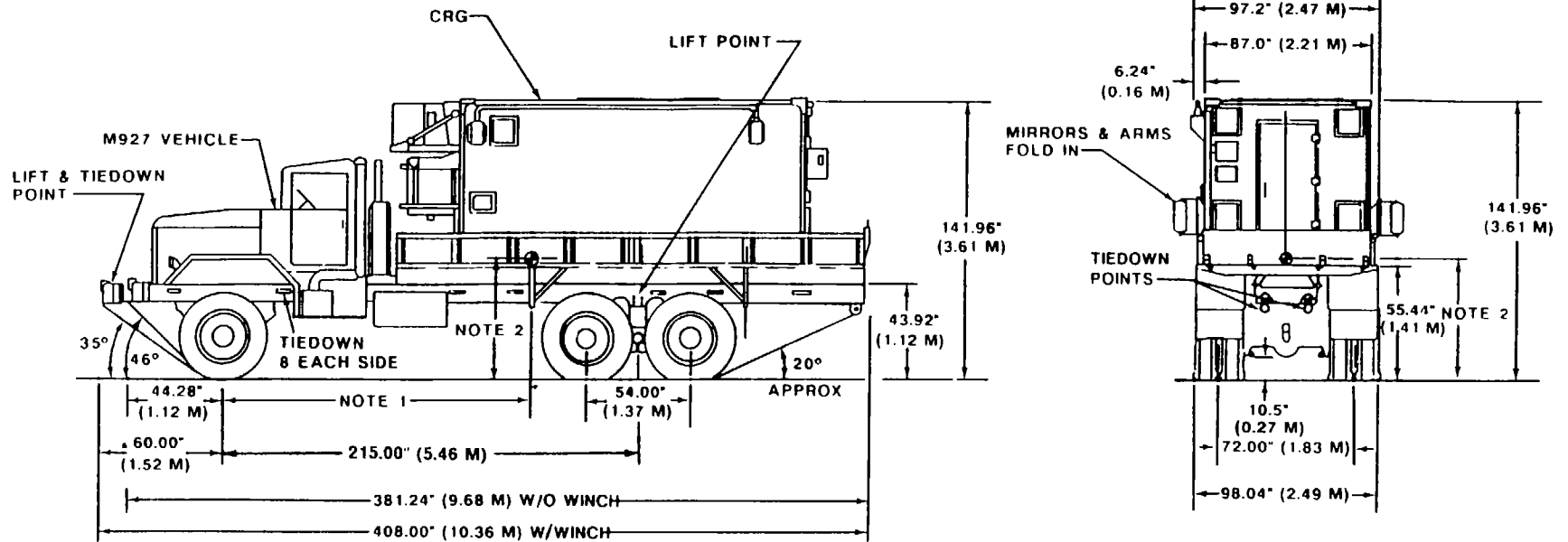

Figure 2-16. M932, 5 ton, 6 x 6 truck-trailer

h. Communication Relay Group (CRG) AN/ MRC-137. The CRG is a shelter mounted on an M927, as shown in figure 2-17. The CRG shelter removed from the prime mover is shown in figure 2-18. The M927, a 5-ton, 6 x 6 truck, is shown in figure 2-19. The CRG is

classified as confidential when shipped with crypto units installed. Under these conditions, shipment requires constant surveillance.



NOTE 1. 159.12" (4.04 M) W/O WINCH
155.52" (3.95 M) W/WINCH

NOTE 2. 56.88" (1.44 M) W/O WINCH
56.64" (1.44 M) W/WINCH

*WITH WINCH

CUBE: WO/WINCH = 3070 FT³ (86.9 M³)
GROSS WEIGHT = 33,390 LB (15 150 KG)

AXLE LOADS

NO. 1 AXLE = 10,060 LB (4 564 KG)
NO. 2 AXLE = 11,665 LB (5 293 KG)
NO. 3 AXLE = 11,665 LB (5 293 KG)

Figure 2-17. Shelter-mounted communication relay group on an M927.

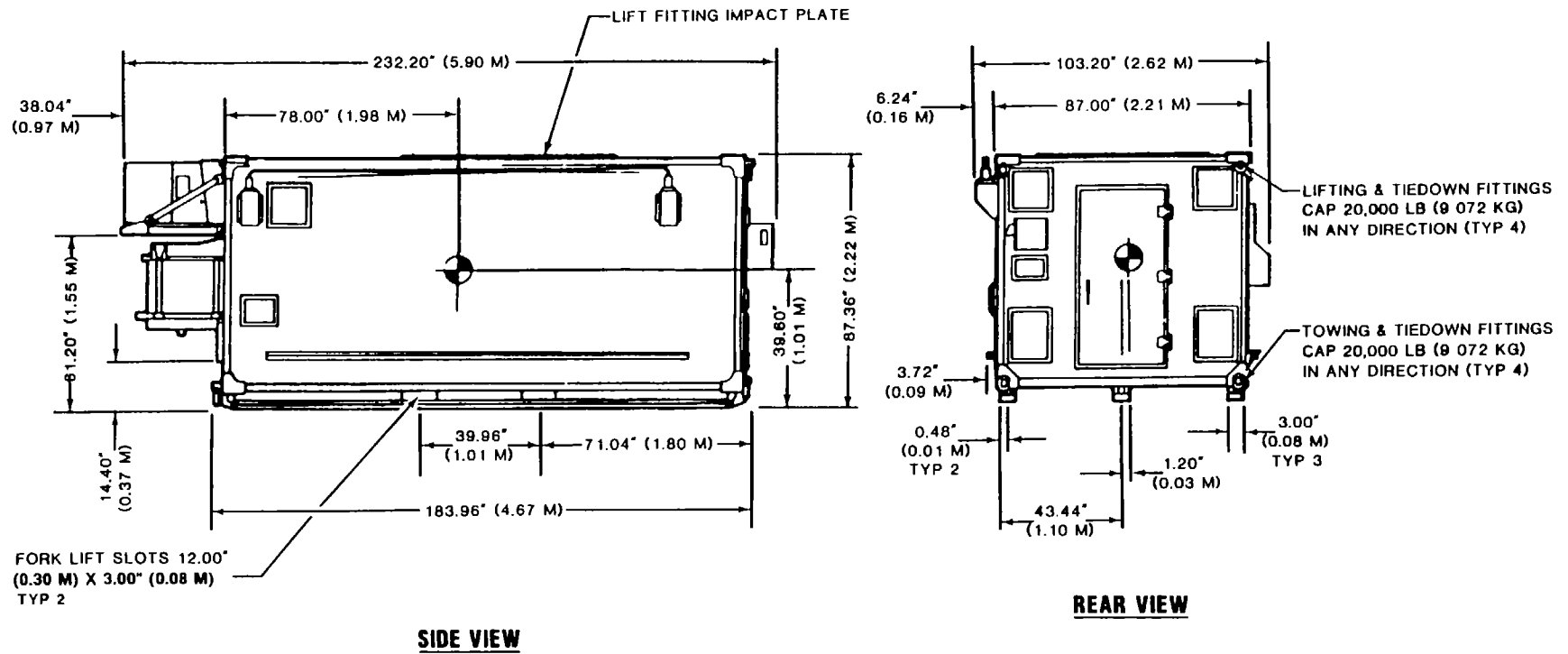

NOTE: GROSS WEIGHT = 9,106 LB (4 136 KG)

Figure 2-18. Communication relay group AN/MRC-137, shelter-mounted.

WEIGHT IN POUNDS (KG)	
CURB WEIGHT	24.300 (11.022)
GROSS VEHICLE WEIGHT	34.300 (15.558)
AXLE LOAD (CURB)	
NO. 1	10.200 (4 627)
NO. 2	7.050 (3 199)
NO. 3	7.050 (3 199)
AXLE LOAD (GVW)	
NO. 1	10.205 (4 629)
NO. 2	12.048 (5 465)
NO. 3	12.048 (5 465)

NSN 2320-01-047-8770 (M927)
 LIN X41242
 NSN 2320-01-047-8771 (M928)
 LIN X41105

	M927	M928
CUBE OPERATIONAL	3.169 FT ³ (89.68 M ³)	3.347 FT ³ (94.71 M ³)
W MIRRORS REMOVED	2.554 FT ³ (72.64 M ³)	2.696 FT ³ (76.32 M ³)
W MIRRORS AND CAB FOLDED	1.968 FT ³ (55.68 M ³)	2.078 FT ³ (58.81 M ³)
AREA OPERATIONAL W MIRRORS FOLDED	260 FT ² (24.15 M ²)	274 FT ² (25.46 M ²)

MAXIMUM SPEED: 55 MPH (88 KM H)
 MAXIMUM RANGE: 300 MILES (483 KM)
 TIRES: 80 PSI (FRONT) 50 PSI (REAR)

FUEL TANK CAPACITY: 81 GAL (307 L)
 FUEL: DIESEL

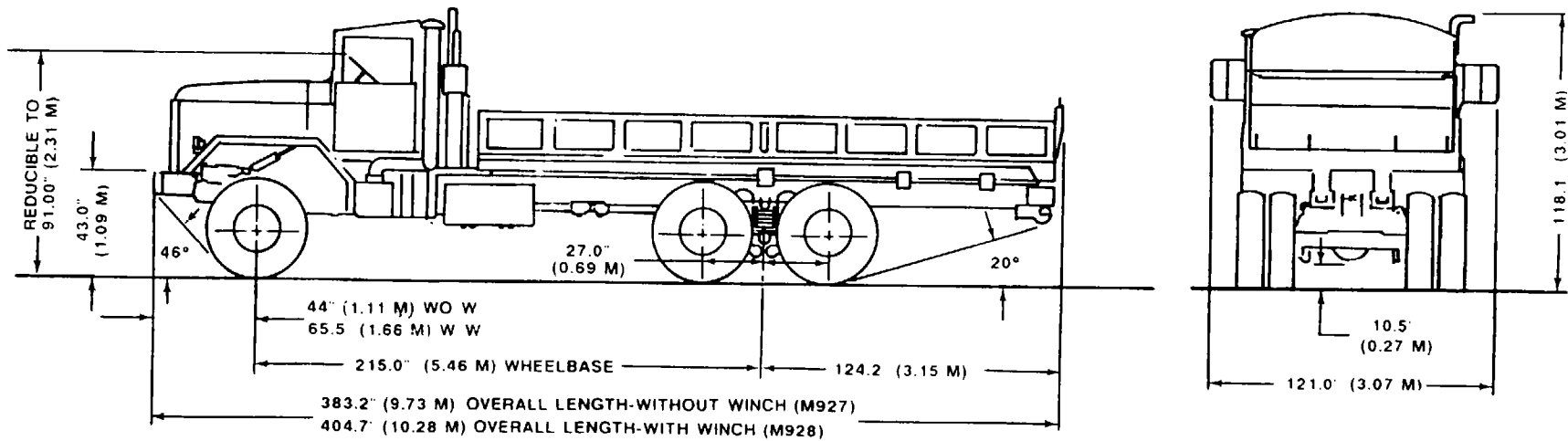

Figure 2-19. M927, 5-ton, 6 x 6 truck.

i. Antenna Mast Group (AMG), OE-346/MRC.
The AMG mounted on the M942 or M942A1 is shown in figure 2-20. The AMG removed from the M942 is shown in figure 2-21. The M942 (fig 2-22) and the M942A1 are 5-ton, 6 x 6 truck chassis. The AMG has two

hydraulically erectable, pneumatically extendable masts. For shipment by all modes, both extendable masts must be restrained as shown in figure 2-23 to prevent extension of the masts.

GROSS WEIGHT = 36,530 (16 574 KG)

AXLE LOADS

- NO. 1 AXLE = 10,400 LB (4 718 KG)
- NO. 2 AXLE = 13,065 LB (5 928 KG)
- NO. 3 AXLE = 13,065 LB (5 928 KG)

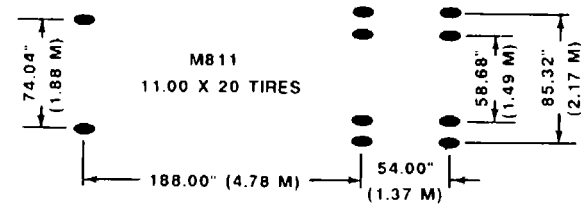

FOOTPRINT DATA

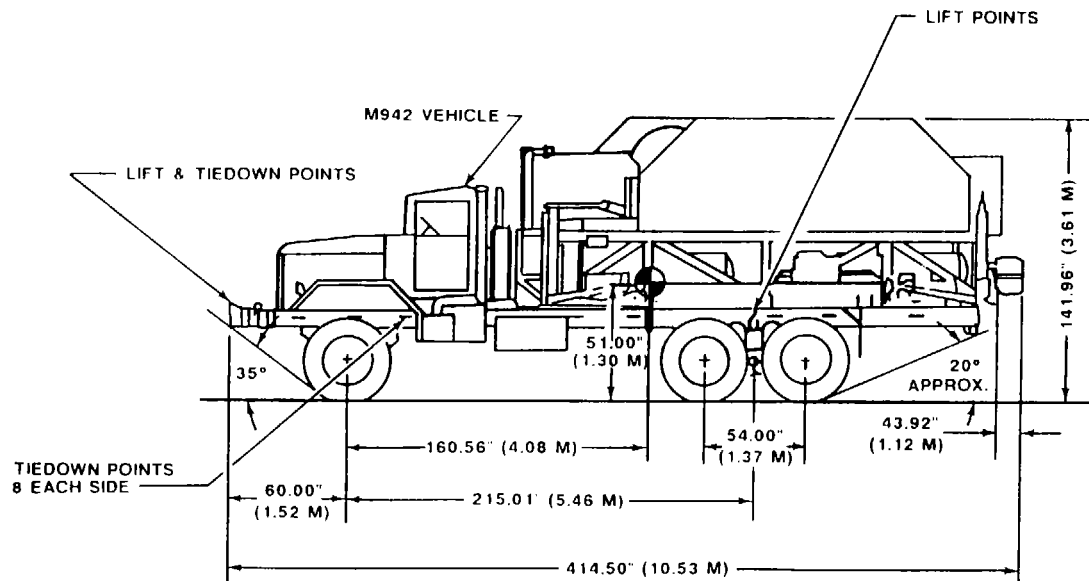

SIDE VIEW

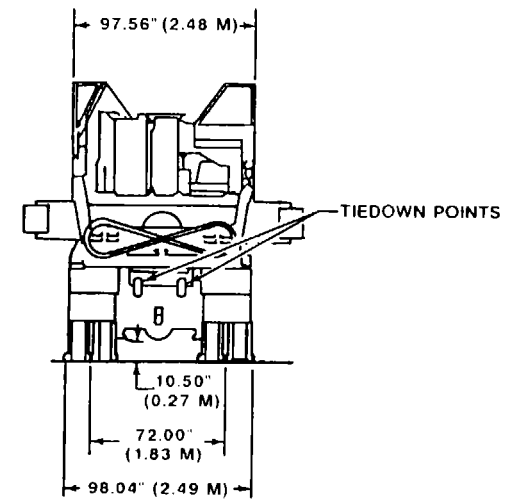

REAR VIEW

Figure 2-20. Antenna mast group mounted on the M942.

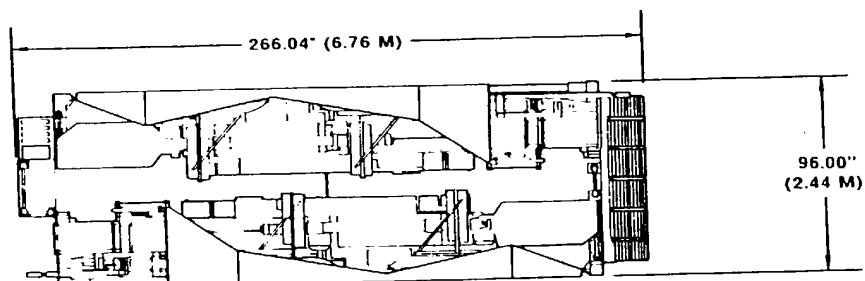

ANTENNA MAST GROUP
GUIDED MISSILE, OFF-LOADED
PLAN VIEW

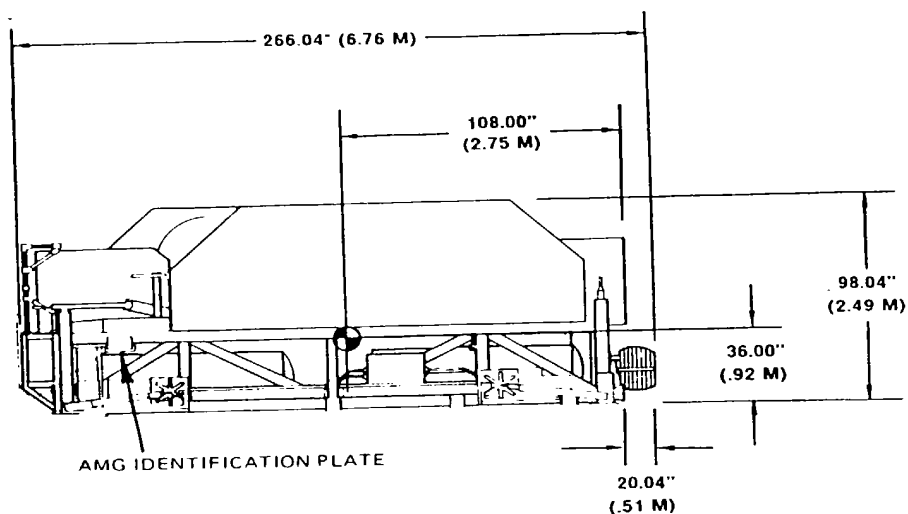

AMG IDENTIFICATION PLATE

ANTENNA MAST GROUP
GUIDED MISSILE, OFF-LOADED
SIDE VIEW

GROSS WEIGHT = 14,500 LB (6 583 KG)

LIFTING AND TIEDOWN FITTINGS
CAP. 10,000 LB (4,536 KG)
IN ANY DIRECTION (TYP 4)

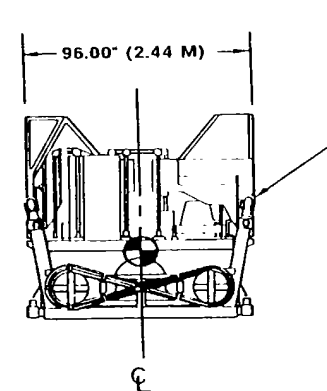

ANTENNA MAST GROUP
GUIDED MISSILE, OFF-LOADED
END VIEW

Figure 2-21. Antenna mast group.

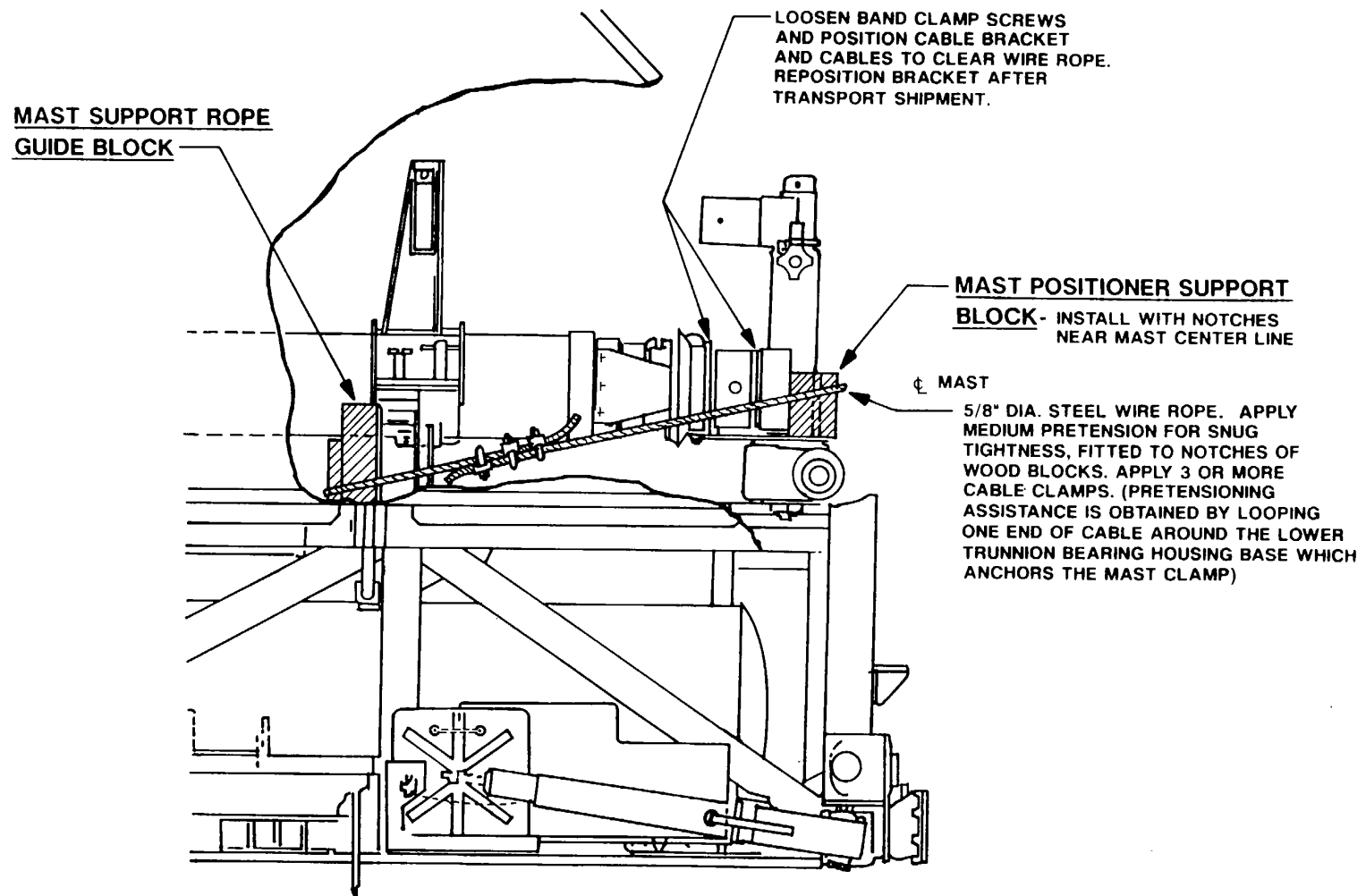
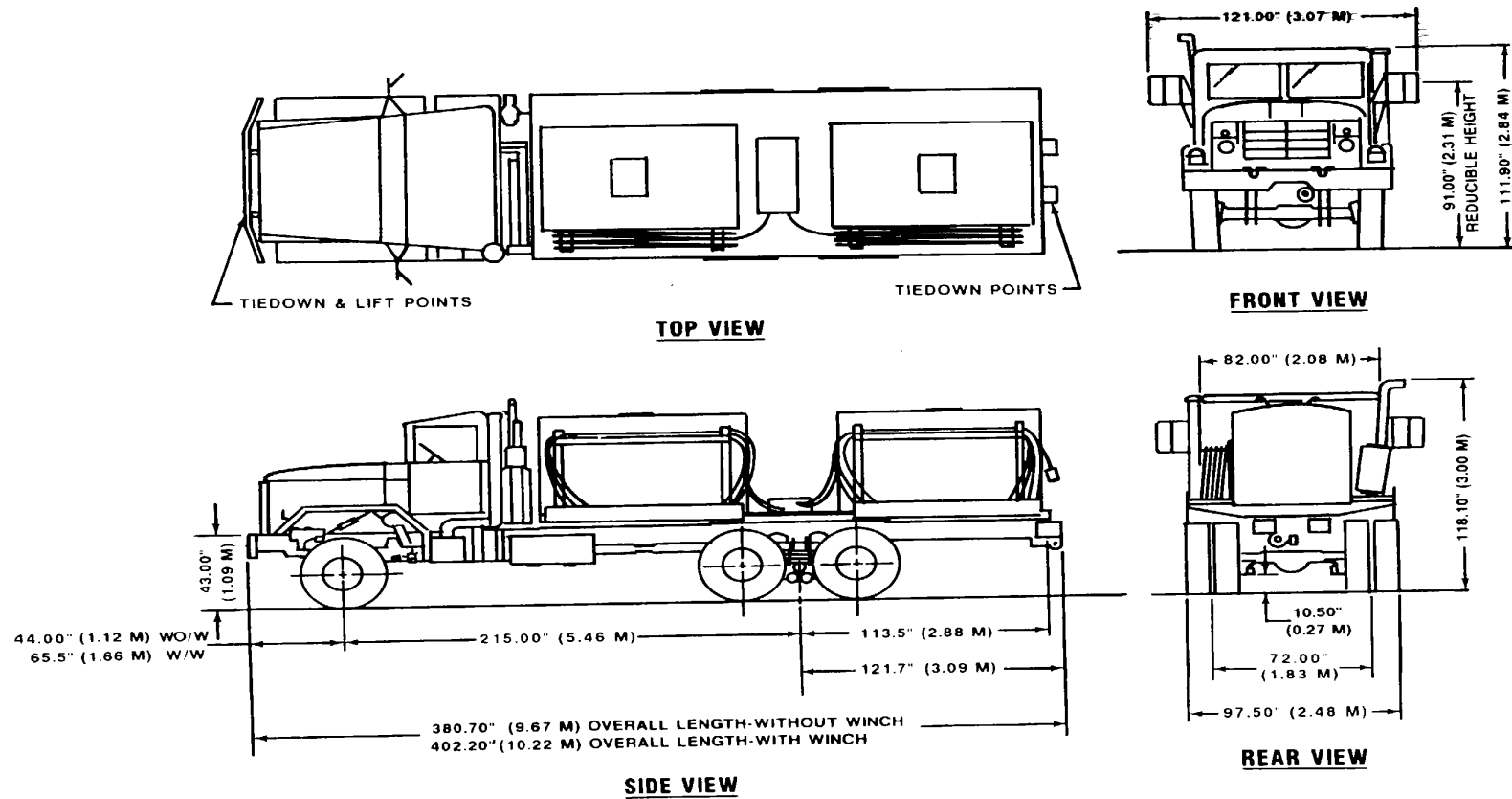

Figure 2-23. Mast restraint and blocking applied to antenna mast group for all modes of transport.

j. *Electrical Power Plant (EPP) AN/MJQ-24, Truck Mounted.* The EPP consists of two 150-kW

generators mounted on the M942, as shown in figure 2-24.



CUBE: WO/WINCH = 2,537 FT³ (71.8 M³)
 GROSS WEIGHT = 32,400 LB (14 727 KG)

AXLE LOADS
 NO. 1 AXLE = 10,480 LB (4 764 KG)
 NO. 2 AXLE = 10,960 LB (4 982 KG)
 NO. 3 AXLE = 10,960 LB (4 982 KG)

Figure 2-24. Electrical power plant AN/MJQ-24, mounted on an M942

k. Electrical Power Unit (EPU II) PU-789/M. Trailer Mounted. The EPU II is a diesel-powered generator

mounted on a modified M353, 3½/2-ton trailer, as shown in figure 2-25.

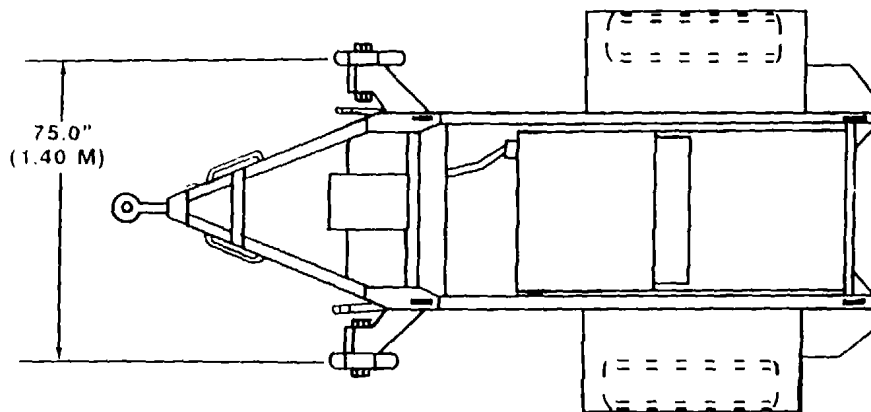

CUBE = 869 FT³ (24.59 M³)
 GROSS WEIGHT = 6,260 LB (2 840 KG)
 AXLE LOAD = 5,310 LB (2 414 KG)

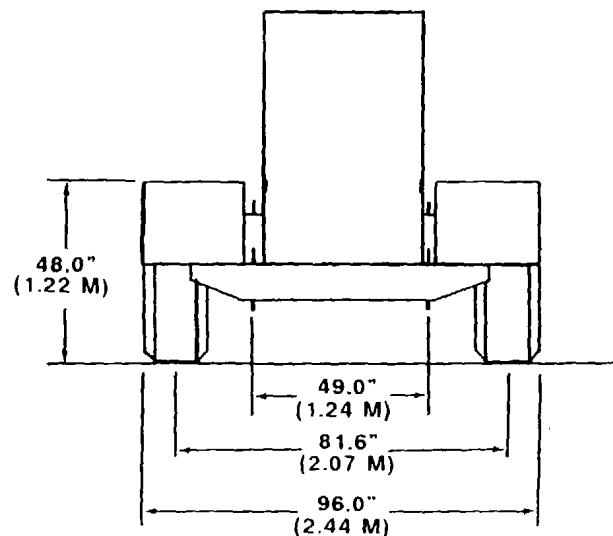
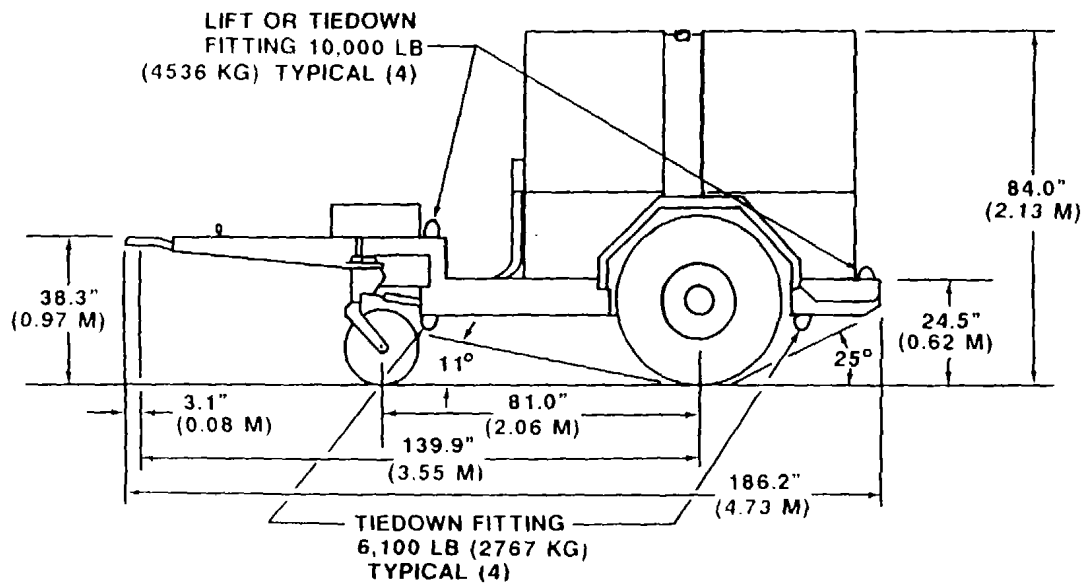

Figure 2-25. Electrical power unit (EPU II) PU-789/M, trailer-mounted

I. Guided Missile, Intercept Aerial MIM-104A. A canister and an enclosed missile comprise the missile round (MR). The canister is reusable for logistics and test operations, but not for practical operations. The canister (fig 2-26) functions as a launch tube and also as a shipping and storage container for the missile. It has

externally indexed mounting and latching mechanisms, for rapid attachment to the LS. The four shipping skid-tie-down type external isolation systems may be removed or remain installed for mounting the canister to the LS.

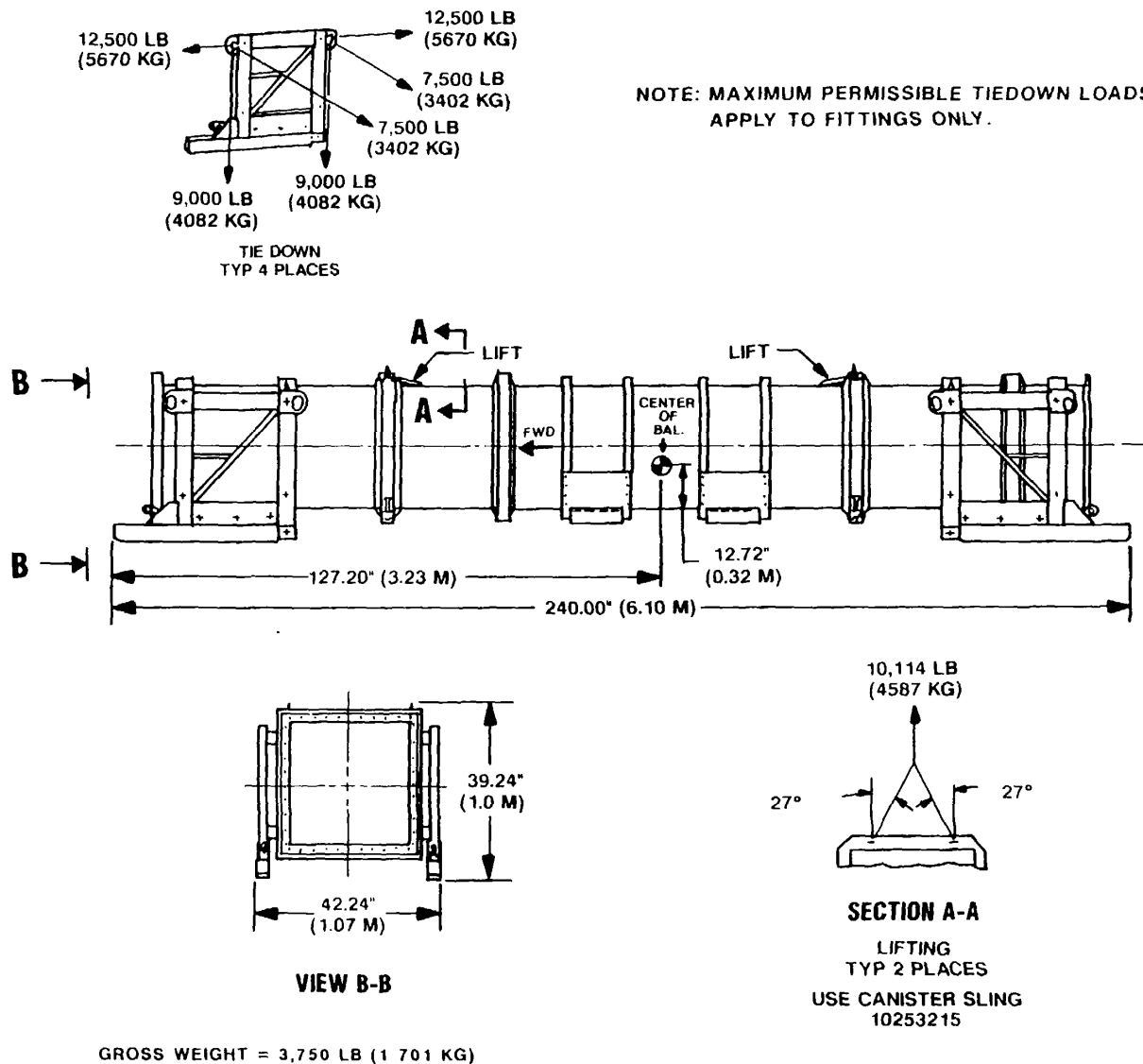

Figure 2-26. Side and end views of missile round (MR) canister.

2-3. Unusual and Hazardous Characteristics

The PATRIOT components have no unusual, hazardous, and dangerous characteristics that require special attention during exposure to normal transportation environments.

NOTE

Those regulations and/or transportation procedures normally associated with vehicles containing diesel fuel and batteries will apply.

**CHAPTER 3
SAFETY**

3-1. General

General safety considerations and precautions for movement are as follows:

- a. Check each vehicle to ensure that all loose items are appropriately secured.
- b. When backing a vehicle, ensure that no personnel or obstructions are in the path of the vehicle.

WARNING

Fire extinguishers must be readily available during all loading and unloading.

WARNING

Provide proper ventilation in confined spaces when loading and unloading vehicles with internal combustion engines. Prolonged exposure to carbon monoxide fumes can be fatal to unprotected humans.

3-2. Specific Safety Requirements

Radar set AN/MPQ-53 cannot be dropped more than ½ -inch. The set contains the following materials that are classified by CFR 49c, ATA-111, and TM 38-250 as radioactive hazardous material.

a. Beryllium Oxide (Be0) in ceramic state is used in the elements (Part No. 10271087) of the phased array antenna.

(1) *US Department of Transportation (DOT) Class.* Nonhazardous, per the current regulations published in DOT, IATA, and TM 38-250. There are no regulations on Beryllium Oxide in ceramic state.

(2) *DOT Article (Name).* Beryllium Compound N.O.S. (Be0) ceramic.

(3) *Compliance with Applicable US Code(s) and Regulations.* A special ruling is required by the Bureau of Explosives and/or DOT Office of Hazardous Materials Operations to cover shipments of Beryllium in a ceramic state.

b. Tritium in electron tubes used in the radar set comparator assembly are as follows:

FSN 1430-449-7969.....	150 millicuries per tube
FSN 1430-712-8422.....	150 millicuries per tube
FSN 1430-157-5981.....	50 millicuries per tube
FSN 5960-449-7994.....	<u>50</u> millicuries per tube

Total 400 millicuries (0.400 curies)

(1) *US Department of Transportation (DOT) Class:* N.A.

(a) Each radioactive electron tube is marked with a standard radioactivity symbol and the isotope identification.

(b) The tritium tubes are exempt from certain packing, labeling, and marking requirements because, at 10.16 centimeters (4.0 inches) from any unpacked device, radioactivity does not exceed 10 millirem per hour. Total radioactivity of a package must not exceed 200 curies, and so forth. As shown above (0.400 curies total), conditions have been met.

(c) Labels and special marking are not required on the radar set shelter; however, the packing slip (which may be a shipping memo, DD 250, and so forth) must contain a shipper's certification and identify this material as Transportation Group VII.

(2) *DOT Article (Name):* Tritium, electron tube.

(3) *Disaster Response Force Requirements:*

(a) *Medical.* If the tube is broken, take necessary precautions to prevent personnel contamination and to clean away the debris. If the material containing radioactive material causes a wound, apply pressure about the wound and/or use a suction cup to stimulate mild bleeding. If the wound is a puncture-type wound and will not bleed, make a small incision to promote free bleeding and to ease cleaning the material from the wound. If the wound is in the extremities, place a tightly constricting band 5.08 cm (2 in.) to 10.16 cm (4 in.) closer to the heart than the place of the wound. Make the band tight enough to constrict the flow of blood in superficial vessels, but not tight enough to stop arterial flow. After first aid has been administered, evacuate the patient to a medical facility for further treatment and monitoring. All such wounds must be examined by a medical officer.

(b) *Cleanup and Disposal.* If the tube is broken, thoroughly clean the surface on which the tube was broken to eliminate the danger of further contamination. The wet method is the recommended procedure. Put on rubber or plastic gloves, and pick up the large fragments using forceps. Place the pieces in a container such as a plastic bag or a glass jar for disposal. Then, using a wet cloth, wipe across the area. Make one wipe at a time and fold the cloth in half, using the clean side for wiping

each time. When the size of the cloth becomes too small, discard it in the disposal container and start with a new cloth. Take care not to rub the radioactive material into the surface being cleaned. Upon completion of the cleanup operation, discard the remaining cloth and the gloves in the disposal container along with the broken pieces and other discarded materials. Then, seal and dispose of the container in accordance with TM 3-261 and AR 755-15.

(4) *Compliance with Applicable US Code(s) and Regulations.* Authorization No. A01-12-09 (US Army) for possession and use of radioactive material. No label is required. The shelter does not exceed the limits imposed by the Federal Code of Regulations Title 49.

c. Traveling Wave Tube (TWT) is located in the RS shelter transmitter.

(1) *US Department of Transportation (DOT) Class: Nonmagnetic.* When packaged for air transport, a substance is considered to be magnetized material if it has a magnetic field strength of 0.002 Gauss or more at 2.13 meters (7 feet) from any point on the surface of the package. The highest magnetic field of the tube is about 0.002 Gauss at 1.37 meters (4.5 feet); therefore, no label or special marking is required.

(2) *DOT Article (Name):* Not applicable.

CHAPTER 4 AIR TRANSPORTABILITY GUIDANCE

4-1. Scope

This chapter provides air transportability guidance for movement of the PATRIOT missile system. It covers technical and physical characteristics of and safety considerations for the PATRIOT system. It also prescribes the materials required to prepare, load, unload, and tie down the PATRIOT system components on US Air Force C-141B and C-5 aircraft.

4-2. Maximum Utilization of Aircraft

The loads described in this chapter are not maximum loads. Additional cargo and/or personnel within allowable cabin load limits and restrictions, prescribed by pertinent aircraft documents and safety regulations, can be transported.

4-3. Applicability

a. US Air Force Aircraft. When prepared for loading as described in paragraphs 4-5 through 4-7, the PATRIOT system components are transportable in C-141B and C-5 aircraft.

b. Tiedown Devices. The PATRIOT system components will be tied down with devices described in Section IV, "General Procedures," in TO IC-141B9 and TO IC-5A-9.

c. Loadmaster. The loadmaster will ensure that the loaded equipment is secured in accordance with the restraint criteria outlined in TO IC141B-9 and TO IC-5A-9.

4-4. Safety

Besides those safety precautions in chapter 3, the following must be taken:

a. The activity offering the equipment for air transport must notify the aircraft commander, or designated representative, when hazardous materials are to be transported. Hazardous materials must be prepared for air shipment in accordance with TM 38-250/AFR 71-4.

b. The fuel tanks on vehicles and power components must be not more than one-half full for both contingency and routine air shipments.

c. The PATRIOT components must be tied down according to procedures in TO 1C-XXX-9. The tiedown diagrams presented in this chapter will satisfy restraint requirements for the C-141B and C-5 aircraft.

d. Each vehicle or component must be checked carefully to ensure that all loose items are properly secured.

e. Cargo tanks of water vehicles must be emptied and purged before loading in aircraft.

CAUTION

**The vehicle must not exceed 3 mph
inside the aircraft or on the loading
ramps.**

4-5. Preparation of Equipment

a. Ensure all parking brakes are serviceable, and no rocks or stones are embedded in the tire treads or between dual wheels.

b. Clean all system vehicles and components to remove dirt, grease, or other debris that could be dislodged during loading, transport, or unloading.

c. Secure equipment within shelters, semi-trailers, or trucks to prevent dislodgment during transport.

d. Remove and stow communication antennas, or fold and secure them within the outline of the components.

e. Remove spare tires from the M977, M983, and GMT M985E1 and secure in truck bed (M977 and M985E1), or palletize them for transport in the C141B aircraft. Fold the HIAB 8108 crane, secure it in the truck bed as described in TM 9-2320-35510.

f. Reduce 5-ton cargo trucks to steering wheel height, for transport in the C-141B aircraft. Secure removed items in cargo bed of the truck.

g. For C-141B transport, sectionalize the LS and RS. The RS, when removed from the M860A1 semitrailer, requires a special shoring pattern to support the shelter on 463L pallets or metric pallets and to transmit the load pressures to the aircraft roller systems, as discussed in paragraph 47d.

h. For C-141B transport, ensure the gross vehicle weight of the M977 and M983 does not exceed 62,000 pounds and the M985E1, 68,000 pounds. When individual axle weights exceed 10,000 pounds, place those axles in compartments I through M. Maximum rear tandem axle weight of the M977 and M983 shall not exceed 32,000 pounds and the M985E1, 38,000 pounds. Maximum forward tandem axle weight must not exceed 30,000 pounds.

i. For C-5 transport, ensure the gross vehicle weight of the M977 and M983 does not exceed 62,000 pounds and the M985E1, 68,000 pounds. Maximum forward tandem axle weight must not exceed 30,000 pounds.

j. Install all four shackles on the M977, M983, and M985E1 (one in each forward and aft tiedown provision). If a shackle is missing, install a screw pin anchor shackle with a pin size of 1.5-inch diameter (NSN 4030-00-169-9297 or equivalent).

k. Check all pneumatic-tired vehicles for proper tire inflation.

l. Weigh vehicles and components to ensure that the GVW and axle weights do not exceed the weights used for air certification or those shown on the data plate of the vehicle.

4-6. Transport of PATRIOT Missile System Components in C-5 Aircraft

a. The PATRIOT components are transportable by US Air Force C-5 aircraft in accordance with Section IV, "General Procedures," of TO IC-15-9 loading instructions. All items in the system can be loaded in the C-5 aircraft without sectionalization.

b. All PATRIOT vehicles in the road-march configuration are transportable on C-5 aircraft. A typical tiedown diagram for the 5-ton truck-mounted item, without trailers, is shown in figure 4-1. Applications of tiedowns are identified in table 4-1. A tiedown diagram for the M983, M977, and M985E1 is shown in figure 4-2, and applications of tiedowns are identified in table 4-2.

Table 4-1. Tiedown Data for the 5-Ton Cargo Trucks in C-5 Aircraft (Fig 4-1)

Tiedown fitting		Tiedown Device		Attach to Item
Designation	Capacity in 1,000 lb	Type	Capacity in 1,000 lb	
C9	25	MB-2	25	Left front bumper frame.
E9	25	MB-2	25	Right front bumper frame.
C10	25	MB-2	25	Left side, front axle.
E10	25	MB-2	25	Right side, front axle.
C19	25	MB-2	25	Right side, rear axle.
E19	25	MB-2	25	Left side, rear axle.
B21	25	MB-2	25	Left rear frame.
F21	25	MB-2	25	Right rear frame.

Table 4-1. Tiedown Data for the 5-Ton Cargo Trucks in C-5 Aircraft (Fig 4-1) - Continued

Tiedown fitting		Tiedown Device		Attach to Item
Designation	Capacity in 1,000 lb	Type	Capacity in 1,000 lb	
C21	25	MB-2	25	Left rear tiedown provision.
E21	25	MB-2	25	Right rear tiedown provision.

Table 4-2. Tiedown Data for the M983, M977, and M985E1 in C-5 Aircraft (Fig 4-2)

Tiedown fitting		Tiedown Device		Attach to Item
Designation	Capacity in 1,000 lb	Type	Capacity in 1,000 lb	
F9	25	MB-2	25	Pintle.
E9	25	MB-2	25	Pintle.
G9	25	MB-2	25	Left rear tiedown fitting.
D9	25	MB-2	25	Right rear tiedown fitting.
F15	25	MB-2	25	Left tiedown fitting forward of No. 3 axle.
E15	25	MB-2	25	Right tiedown fitting forward of No. 3 axle.
F16	25	MB-2	25	Left tiedown fitting aft of No. 2 axle.
E16	25	MB-2	25	Right tiedown fitting aft of No. 2 axle.
F20	25	MB-2	25	Left tiedown fitting forward of No. 1 axle.
E20	25	MB-2	25	Right tiedown fitting forward of No. 1 axle.
G21	25	MB-2	25	Left forward tiedown fitting.
D21	25	MB-2	25	Right forward tiedown fitting.
G22	25	MB-2	25	Left forward tiedown fitting.

Table 4-2. Tiedown Data for the M983, M977, and M985E1 in C-5 Aircraft (Fig 4-2) - Continued

Tiedown fitting		Tiedown Device		Attach to Item
Designation	Capacity in 1,000 lb	Type	Capacity in 1,000 lb	
D22	25	MB-2	25	Right forward tiedown fitting.

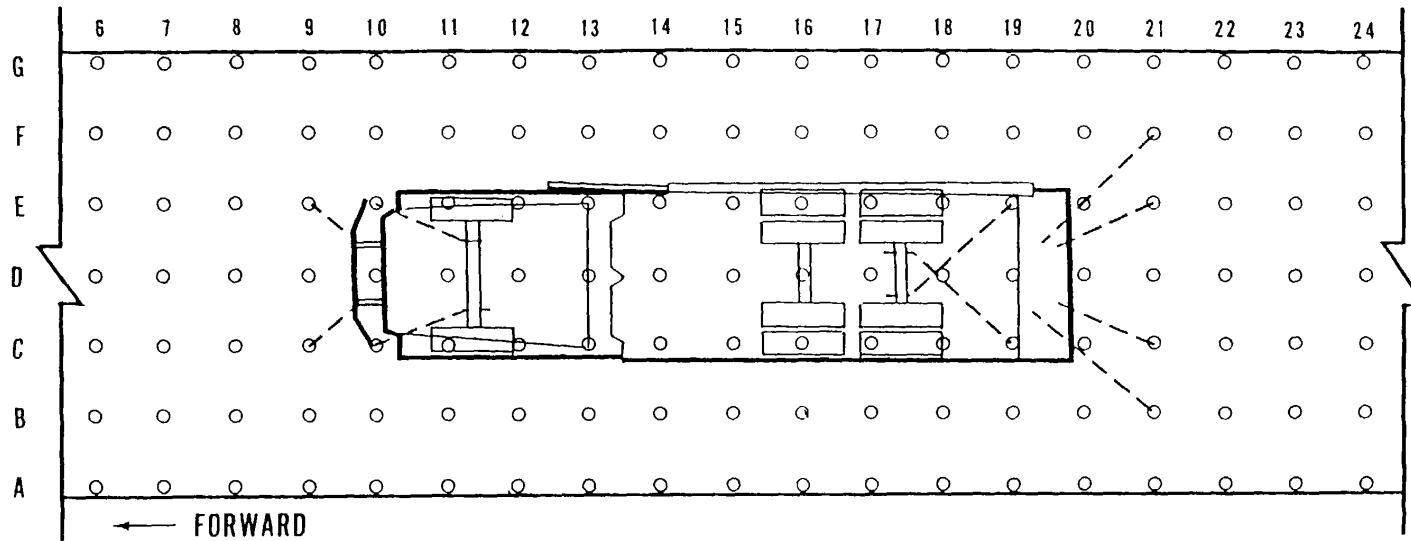

LEGEND: C-5 AIRCRAFT

○ ALL CARGO TIEDOWN FITTING RATINGS 25000 LB EACH

NOTE: FLOOR TIEDOWN FITTINGS ARE LOCATED IN ROWS A THROUGH G AND COLUMNS 1 THROUGH 38. ADDITIONAL COLUMNS OF TIEDOWNS ARE LOCATED ON THE RAMPS: FOUR ON THE FORWARD RAMP AND FIVE ON THE AFT RAMP. THIS IS A TYPICAL TIEDOWN PROCEDURE AND ONLY COLUMNS 6 THROUGH 24 ARE SHOWN. ITEM BEING SHIPPED CAN BE TIED DOWN AT ANY LOCATION APPROVED BY THE LOADMASTER.

Figure 4-1. Typical tiedown diagram for the ECS, ICC, MC (Con Mnt), EPP, CRG, and AMG mounted on 5-ton trucks in C-5 aircraft.

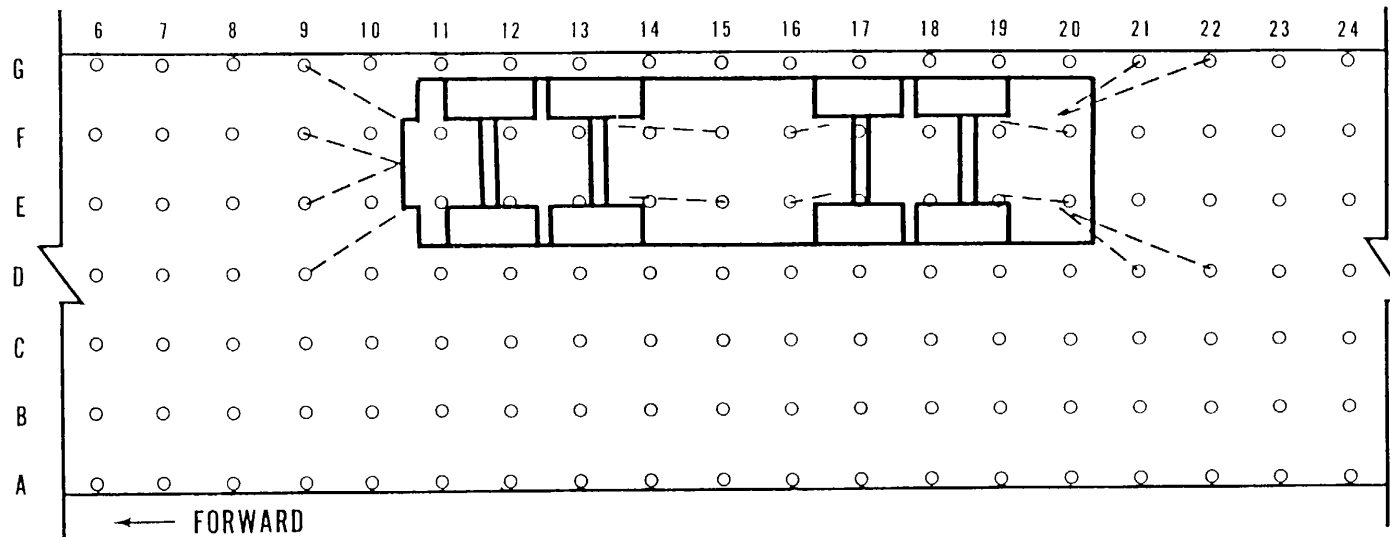

LEGEND: C-5 AIRCRAFT

○ ALL CARGO TIEDOWN FITTING RATINGS 25,000 LB EACH

NOTE: FLOOR TIEDOWN FITTINGS ARE LOCATED IN ROWS A THROUGH G AND COLUMNS 1 THROUGH 38. ADDITIONAL COLUMNS OF TIEDOWNS ARE LOCATED ON THE RAMPS: FOUR ON THE FORWARD RAMP AND FIVE ON THE AFT RAMP. THIS IS A TYPICAL TIEDOWN PROCEDURE AND ONLY COLUMNS 6 THROUGH 24 ARE SHOWN. ITEM BEING SHIPPED CAN BE TIED DOWN AT ANY LOCATION APPROVED BY THE LOADMASTER.

Figure 4-2..Typical tiedown diagram for the M983, M977, and M985E1 vehicles in C-5 aircraft.

c. Loading and tiedown of the PATRIOT system two- and four-wheel trailers are basically the same, except one piece of 2- by 12- by 18-inch lumber is placed beneath the landing gear that has no pneumatic rubber tries. Also, six pieces of 20 by 6 by 80-inch lumber are placed beneath the frame just behind the landing gear of the M353 trailer-mounted items. A typical tiedown diagram for trailer-mounted items is shown in figure 4-3. Applications of tiedowns are identified in table 43. The M353 trailer should be backed into the aircraft with a 2V/2-ton truck equipped with a pintle hook, attached to the front bumper.

CAUTION

The M353 trailer with mounted items of the PATRIOT system and connected to the rear pintle of the 5-ton trucks will impact the aircraft near the ramp hinge. This action will occur during backing into or towing out of the C-5 aircraft when the C-5 is in the forward kneeled loading position.

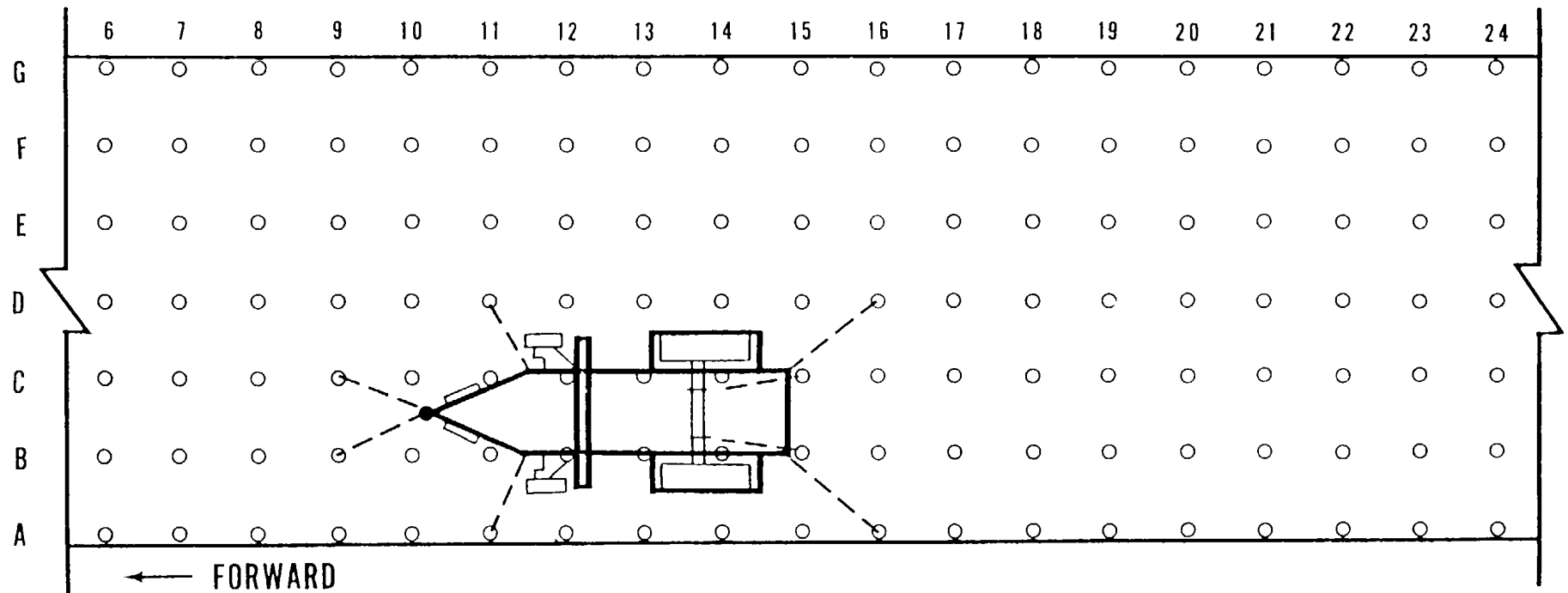

LEGEND: C-5 AIRCRAFT

○ ALL CARGO TIEDOWN FITTING RATINGS 25,000 LB EACH

NOTE: FLOOR TIEDOWN FITTINGS ARE LOCATED IN ROWS A THROUGH G AND COLUMNS 1 THROUGH 38. ADDITIONAL COLUMNS OF TIEDOWNS ARE LOCATED ON THE RAMPS: FOUR ON THE FORWARD RAMP AND FIVE ON THE AFT RAMP. THIS IS A TYPICAL TIEDOWN PROCEDURE AND ONLY COLUMNS 6 THROUGH 24 ARE SHOWN. ITEM BEING SHIPPED CAN BE TIED DOWN AT ANY LOCATION APPROVED BY THE LOADMASTER.

Figure 4-3. Typical tiedown diagram for the PATRIOT trailer-mounted EPUs in C-5 aircraft.

Table 4-3. Tiedown Data for the PATRIOT Trailer-Mounted EPU's in C-5 Aircraft (Fig 4-3)

Tiedown fitting		Tiedown Device		Attach to Item
Designation	Capacity in 1,000 lb	Type	Capacity in 1,000 lb	
B9	25	MB-1	10	Lunette.
C9	25	MB-1	10	Lunette.
All	25	MB-1	10	Left forward tiedown fitting.
D11	25	MB-1	10	Right forward tiedown fitting.
B15	25	MB-1	10	Axle.
C15	25	MB-1	10	Axle.
A16	25	MB-1	10	Left rear tiedown fitting.
D16	25	MB-1	10	Right rear tiedown fitting.

A typical tiedown diagram for the semitrailer-mounted RS or LS towed by an M983 truck-tractor loaded as one item is shown in figure 4-4, and applications of tiedowns are identified in table 4-4. A typical tiedown diagram for an M373A2 semitrailer-mounted MC (Btry), MC (B), or SRPT towed by an M931 or M932 loaded as one item is shown in figure 4-5. Applications of tiedowns are identified in table 4-5.

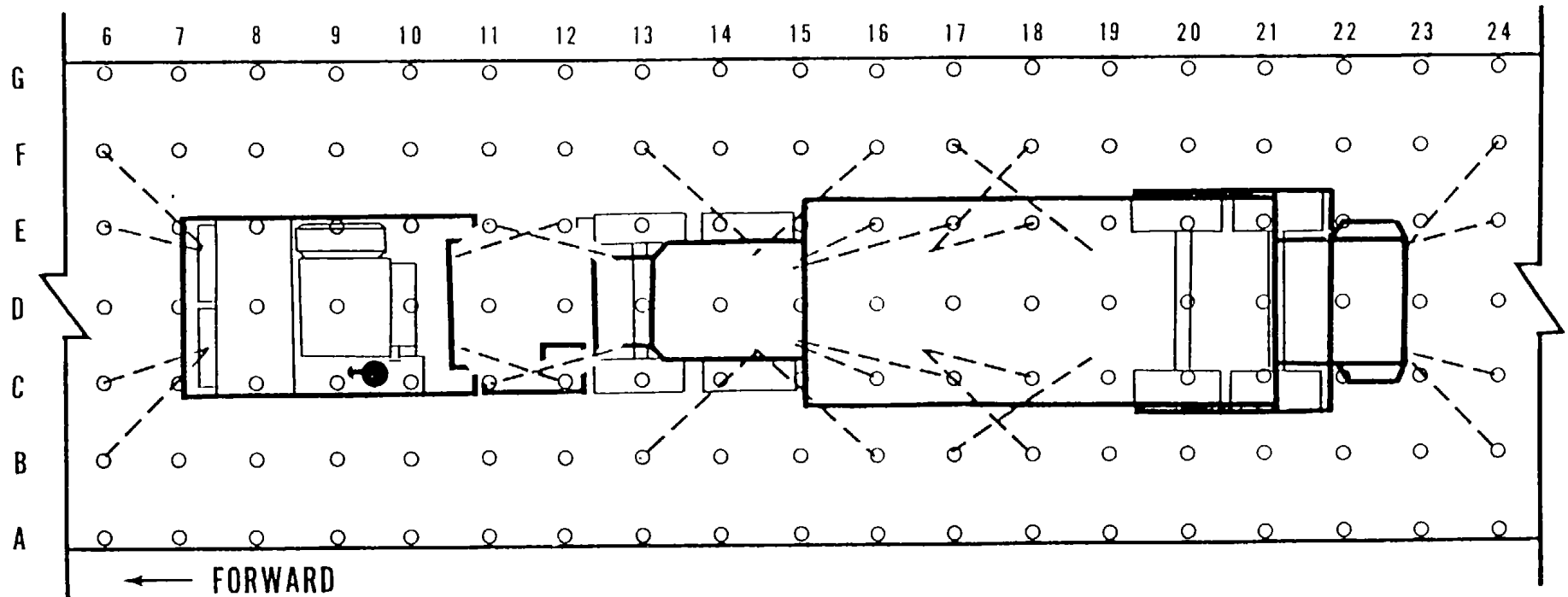

LEGEND: C-5 AIRCRAFT

- ALL CARGO TIEDOWN FITTING RATINGS 25,000 LB EACH

NOTE: FLOOR TIEDOWN FITTINGS ARE LOCATED IN ROWS A THROUGH G AND COLUMNS 1 THROUGH 38. ADDITIONAL COLUMNS OF TIEDOWNS ARE LOCATED ON THE RAMPS: FOUR ON THE FORWARD RAMP AND FIVE ON THE AFT RAMP. THIS IS A TYPICAL TIEDOWN PROCEDURE AND ONLY COLUMNS 6 THROUGH 24 ARE SHOWN. ITEM BEING SHIPPED CAN BE TIED DOWN AT ANY LOCATION APPROVED BY THE LOADMASTER.

Figure 4-4. Typical tiedown diagram for the PATRIOT semitrailer-mounted RS or LS, towed by an M983 truck-tractor, in C-5 aircraft.

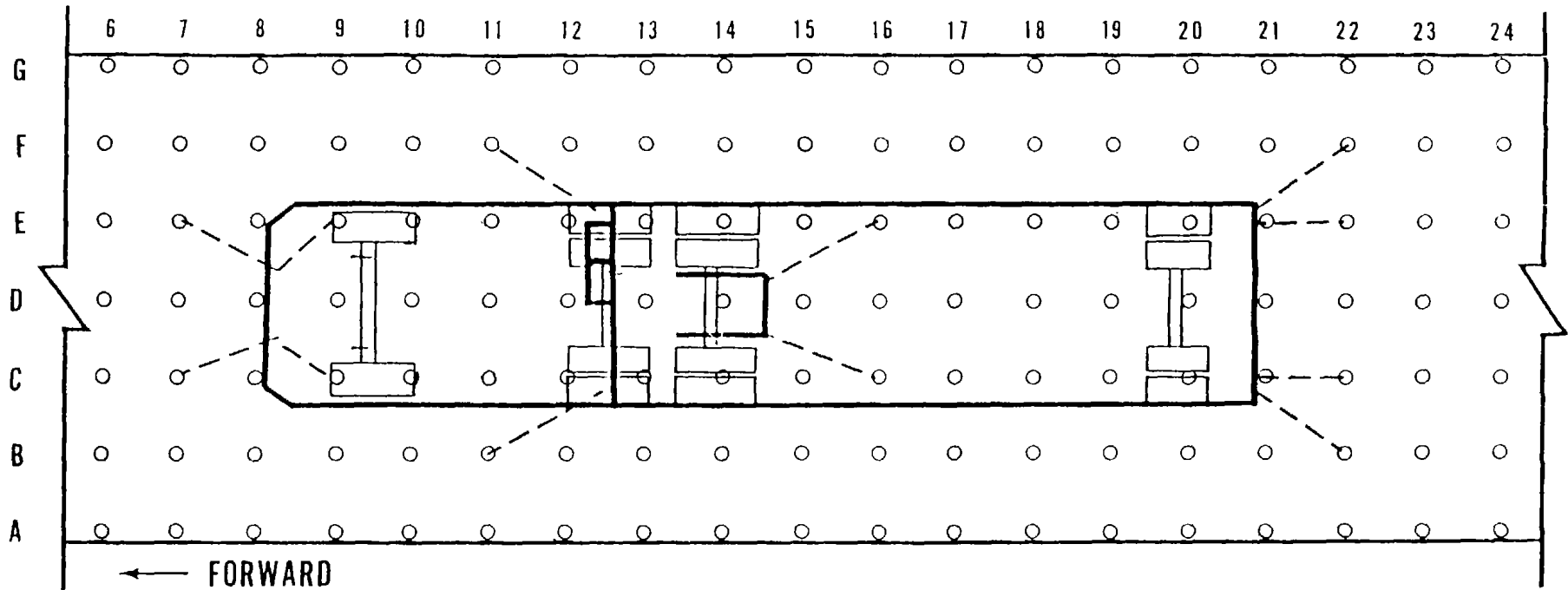

LEGEND: C-5 AIRCRAFT

○ ALL CARGO TIEDOWN FITTING RATINGS 25,000 LB EACH

NOTE: FLOOR TIEDOWN FITTINGS ARE LOCATED IN ROWS A THROUGH G AND COLUMNS 1 THROUGH 38. ADDITIONAL COLUMNS OF TIEDOWNS ARE LOCATED ON THE RAMPS: FOUR ON THE FORWARD RAMP AND FIVE ON THE AFT RAMP. THIS IS A TYPICAL TIEDOWN PROCEDURE AND ONLY COLUMNS 6 THROUGH 24 ARE SHOWN. ITEM BEING SHIPPED CAN BE TIED DOWN AT ANY LOCATION APPROVED BY THE LOADMASTER.

Figure 4-5. Typical tiedown diagram for the PATRIOT semitrailer-mounted MC (Btry), MC (Bn), or SRPT, towed by an M931 or M932 truck-tractor, in C-5 aircraft.

4-7. Transport of PATRIOT Missile System Components in C-141B Aircraft

a. The PATRIOT components are transportable by US Force C-141B aircraft in accordance with Section IV, "General Procedures," of the TO 1C141B-9 loading instructions. All items in the system, except the EPU, are loaded in the C-141B in their reduced configuration. The EPU mounted on the M353 trailer is loaded in its operational configuration.

b. Loading and unloading of the ECS, ICC, MC (Contact Maint), CRG, and AMG require removal from their 5-ton cargo truck. The M983, M977, and M985E1 can be loaded in their reduced configuration with a height limited load. A typical tiedown diagram for the 5-ton cargo trucks is shown in figure 4-6, and applications of tiedowns are identified in table 4-6. Shelter-mounted components secured to three married HCU-6/E (463L) pallets for straight-in loading from a K-loader or semitrailer is shown in figure 4-7, and applications of tiedowns are identified in table 4-7. Shelters with elastomeric skid bases will be locked in the cushioning mode. Place 2by 8by 192-inch lumber, doubled, between skids and pallets. A typical tiedown diagram for the 10-ton vehicles, M983, M977, and M985E1, is shown in figure 4-8, and applications of tiedowns are identified in table 4-8.

Table 4-4. Tiedown Data for the PATRIOT, Semitrailer-Mounted RS or LS Towed by an M983 Truck-Tractor, in C-5 Aircraft (Fig 4-4)

Tiedown fitting		Tiedown Device		Attach to Item
Designation	Capacity in 1,000 lb	Type	Capacity in 1,000 lb	
C6	25	MB-2	25	Left front tiedown provision.
E6	25	MB-2	25	Right front tiedown provision.
B6	25	MB-2	25	Left front tiedown provision.
F6	25	MB-2	25	Right front tiedown provision.
C12	25	MB-2	25	Left frame tiedown ring aft of, No. 2 axle.
E12	25	MB-2	25	Right frame tiedown ring aft of, No. 2 axle.

Table 4-4. Tiedown Data for the PATRIOT, Semitrailer-Mounted RS or LS Towed by an M983 Truck-Tractor, in C-5 Aircraft (Fig 4-4)-Continued

Tiedown fitting		Tiedown Device		Attach to Item
Designation	Capacity in 1,000 lb	Type	Capacity in 1,000 lb	
C11	25	MB-2	25	Left frame tiedown ring aft of, No. 3 axle.
E11	25	MB-2	25	Right frame tiedown ring aft of, No. 3 axle.
B13	25	MB-2	25	Left gooseneck tiedown provision.
F13	25	MB-2	25	Right gooseneck tiedown provision.
B16	25	MB-2	25	Left gooseneck tiedown provision.
F16	25	MB-2	25	Right gooseneck tiedown provision.
C16	25	MB-2	25	Left rear tractor tiedown provision.
E16	25	MB-2	25	Right rear tractor tiedown provision.
C17	25	MB-2	25	Left rear tractor tiedown provision.
E17	25	MB-2	25	Right rear tractor tiedown provision.
B17	25	MB-2	25	Left frame tiedown provision forward of semitrailer axles.
F17	25	MB-2	25	Right frame tiedown provision forward of semitrailer axles.
C18	25	MB-2	25	Left forward frame tiedown provision.

Table 4-4. Tiedown Data for the PATRIOT, Semitrailer-Mounted RS or LS Towed by an M983 Truck-Tractor, in C-5 Aircraft (Fig 4-4)-Continued

Tiedown fitting		Tiedown Device		Attach to Item
Designa- ton	Capacity in 1,000 lb	Type	Capacity in 1,000 lb	
E18	25	MB-2	25	Right forward frame tiedown provision.
B18	25	MB-2	25	Left forward frame tiedown provision.
F18	25	MB-2	25	Right forward frame tiedown provision.
C24	25	MB-2	25	Left rear tiedown provision.
E24	25	MB-2	25	Right rear tiedown provision.
B24	25	MB-2	25	Left rear tiedown provision.
F24	25	MB-2	25	Right rear tiedown provision.

Table 4-5. Tiedown Data for the PATRIOT Semitrailer Mounted MC (Btry), MC (Bn), or SRPT, Towed by an M931 or M932 Truck-Tractor, in C-5 Aircraft (Fig 4-5)

Tiedown fitting		Tiedown Device		Attach to Item
Designa- ton	Capacity in 1,000 lb	Type	Capacity in 1,000 lb	
C7	25	MB-2	25	Left forward frame.
E7	25	MB-2	25	Right forward frame.
C9	25	MB-2	25	Left forward frame.
E9	25	MB-2	25	Right forward frame.
B11	25	MB-2	25	Left forward semitrailer tiedown ring.
F11	25	MB-2	25	Right forward semitrailer tiedown ring.
C16	25	MB-2	25	Left rear tiedown.
E16	25	MB-2	25	Right rear tiedown.
B22	25	MB-2	25	Left outboard semitrailer tiedown ring.
C22	25	MB-2	25	Left inboard semitrailer tiedown ring.
E22	25	MB-2	25	Right inboard semitrailer tiedown ring.
F22	25	MB-2	25	Right outboard semitrailer tiedown ring.

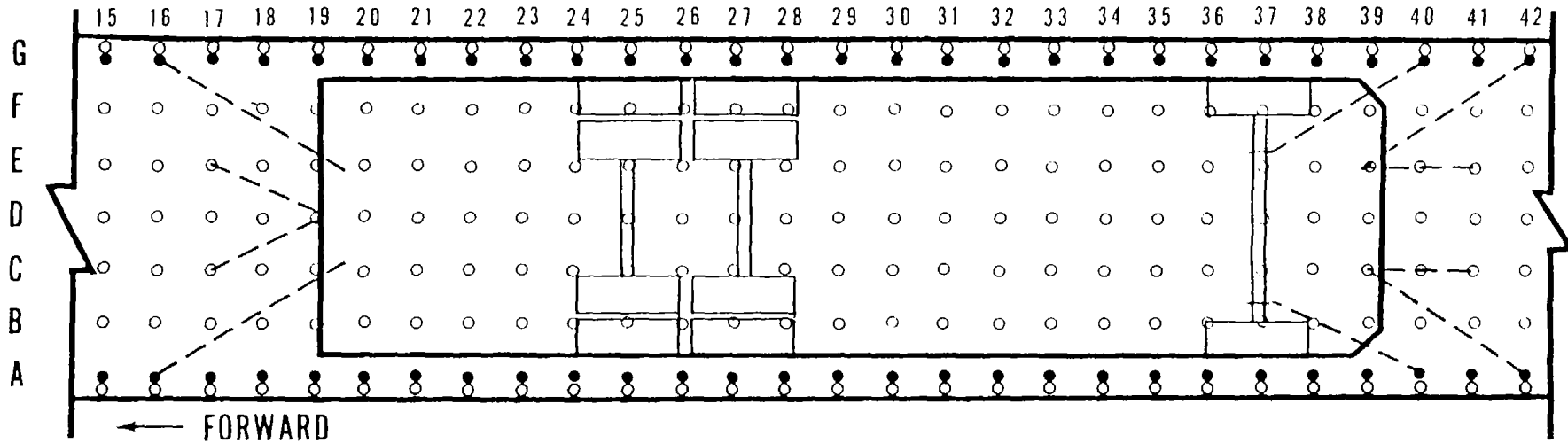

LEGEND: C-141 AIRCRAFT

- 10,000-POUND-CAPACITY TIEDOWN FITTING
- 25,000-POUND-CAPACITY TIEDOWN FITTING

NOTE: FLOOR TIEDOWN FITTINGS ARE LOCATED IN ROWS A THROUGH G AND COLUMNS 1 THROUGH 56. THE RAMP HAS 6 ADDITIONAL COLUMNS. THIS IS A TYPICAL TIEDOWN PROCEDURE AND ONLY COLUMNS 15 THROUGH 42 ARE SHOWN. ITEM BEING SHIPPED CAN BE TIED DOWN AT ANY LOCATION APPROVED BY THE LOADMASTER.

Figure 4-6. Typical tiedown diagram for PATRIOT 5-ton cargo trucks in C-141B aircraft.

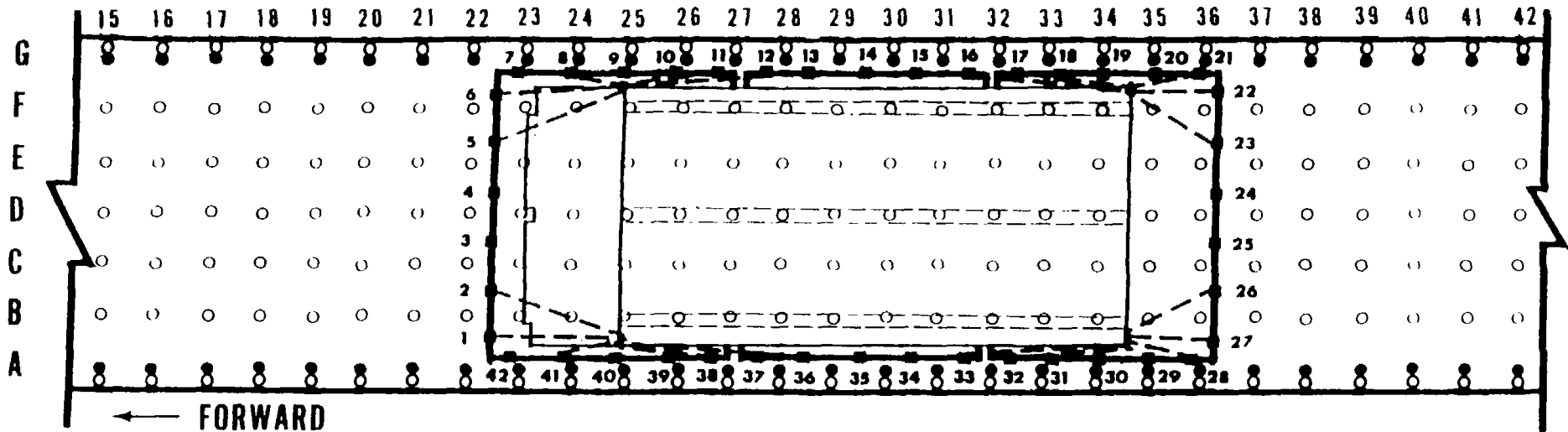

LEGEND: C-141 AIRCRAFT

- 10,000-POUND-CAPACITY TIEDOWN FITTING
- 25,000-POUND-CAPACITY TIEDOWN FITTING

NOTE: FLOOR TIEDOWN FITTINGS ARE LOCATED IN ROWS A THROUGH G AND COLUMNS 1 THROUGH 56. THE RAMP HAS 6 ADDITIONAL COLUMNS. THIS IS A TYPICAL TIEDOWN PROCEDURE AND ONLY COLUMNS 15 THROUGH 42 ARE SHOWN. ITEM BEING SHIPPED CAN BE TIED DOWN AT ANY LOCATION APPROVED BY THE LOADMASTER.

Figure 4-7. Typical tiedown diagram for the PATRIOT shelter-mounted components secured to three married HCU-6/E (463L) pallets for loading in C-141B aircraft.

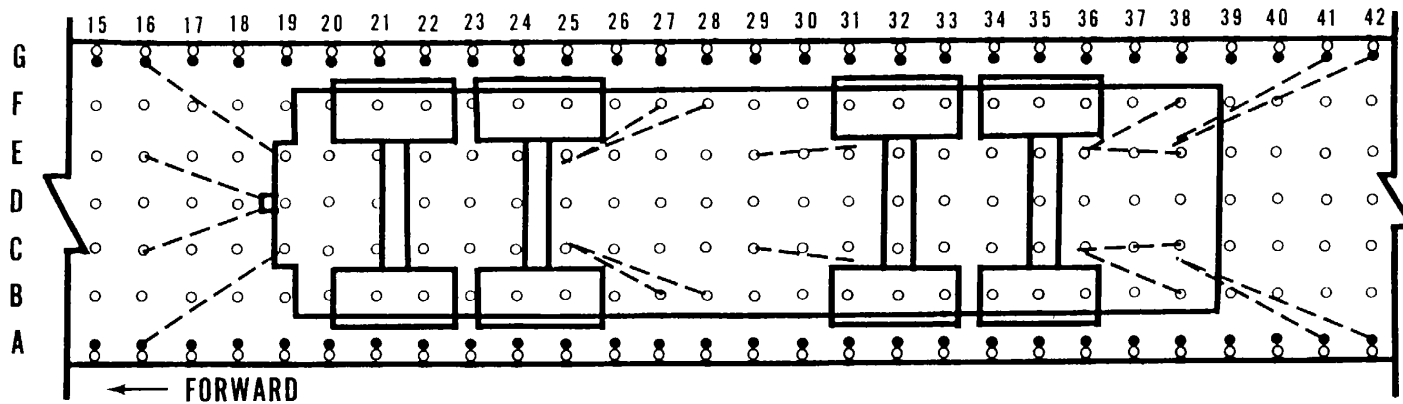

LEGEND: C-141 AIRCRAFT

- 10,000-POUND-CAPACITY TIEDOWN FITTING
- 25,000-POUND-CAPACITY TIEDOWN FITTING

NOTE: FLOOR TIEDOWN FITTINGS ARE LOCATED IN ROWS A THROUGH G AND COLUMNS 1 THROUGH 56. THE RAMP HAS 6 ADDITIONAL COLUMNS. THIS IS A TYPICAL TIEDOWN PROCEDURE AND ONLY COLUMNS 15 THROUGH 42 ARE SHOWN. ITEM BEING SHIPPED CAN BE TIED DOWN AT ANY LOCATION APPROVED BY THE LOADMASTER.

Figure 4-8. Typical tiedown diagram for the M983, M977, and M985E1 vehicles in C-141B aircraft.

c. Loading and tiedown of the PATRIOT system two-and four-wheel trailers are basically the same. One piece of 2by 12by 18-inch lumber is placed beneath the landing gear not equipped with pneumatic tires. Six pieces of 2by 6by 80-inch lumber are placed beneath the frame just behind the landing gear of the M353 trailer-mounted items. A typical tiedown diagram for trailer-mounted items is shown in figure 4-9, and applications of tiedowns are identified in table 4-9. The M353 trailer should be backed onto the C-141B with a 21/2-ton truck equipped with a pintle hook attached to the front bumper.

Table 4-6. Tiedown Data for the 5-ton Cargo Trucks in C-141B Aircraft (Fig 4-6)

Tiedown fitting		Tiedown Device		Attach to Item
Designa-ton	Capacity in 1,000 lb	Type	Capacity in 1,000 lb	
A16	25	MB-2	25	Right rear frame.
G16	25	MB-2	25	Left rear frame.
C17	10	MB-1	10	Pintle.
E17	10	MB-1	10	Pintle.
A40	25	MB-2	25	Right front axle.
G40	25	MB-2	25	Left front axle.
C41	10	MB-1	10	Right front frame.
E41	10	MB-1	10	Left front frame.
A42	25	MB-2	25	Right front frame.
G42	25	MB-2	25	Left front frame.

Table 4-7. Tiedown Data for the PATRIOT Engagement Control Station Mounted in a Shelter with Data Link Antenna Removed and Secured on Three Married 463L Pallets (HCU-6/E) (Fig 4-7)

Tiedown fitting		Tiedown Device		Attach to Item
Designa-ton	Capacity in 1,000 lb	Type	Capacity in 1,000 lb	
1	7.5	MB-1	10	Lower left towing fitting.
2	7.5	MB-1	10	Lower left towing fitting.
5	7.5	MB-1	10	Lower right towing fitting.
6	7.5	MB-1	10	Lower right towing fitting.

Table 4-7. Tiedown Data for the PATRIOT Engagement Control Station Mounted in a Shelter with Data Link Antenna Removed and Secured on Three Married 463L Pallets (HCU-6/E) (Fig 4-7)Continued

Tiedown fitting		Tiedown Device		Attach to Item
Designa-ton	Capacity in 1,000 lb	Type	Capacity in 1,000 lb	
8	7.5	MB-1	10	Upper right forward tiedown fitting.
11	7.5	MB-1	10	Upper right forward tiedown fitting.
12	7.5	MB-1	10	Upper right forward tiedown fitting.
16	7.5	MB-1	10	Upper right rear tiedown fitting.
17	7.5	MB-1	10	Upper right rear tiedown fitting.
21	7.5	MB-1	10	Upper right rear tiedown fitting.
22	7.5	MB-1	10	Lower right rear towing fitting.
23	7.5	MB-1	10	Lower right rear towing fitting.
26	7.5	MB-1	10	Lower left rear towing fitting.
27	7.5	MB-1	10	Lower left rear towing fitting.
28	7.5	MB-1	10	Upper left rear tiedown fitting.
32	7.5	MB-1	10	Upper left rear tiedown fitting.
33	7.5	MB-1	10	Upper left rear tiedown fitting.
37	7.5	MB-1	10	Upper left forward tiedown fitting.
38	7.5	MB-1	10	Upper left forward tiedown fitting.
41	7.5	MB-1	10	Upper left forward tiedown fitting.

Table 4-8. Tiedown Data for the M983, M977, and M985E1 in C-141B Aircraft (Fig 4-8)

Tiedown fitting		Tiedown Device		Attach to Item
Designation	Capacity in 1,000 lb	Type	Capacity in 1,000 lb	
C16	10	MB-1	10	Pintle.
E16	10	MB-1	10	Pintle.
A16	25	MB-2	25	Right rear tiedown fitting.
G16	25	MB-2	25	Left rear tiedown fitting.
B27	10	MB-1	10	Right tiedown fitting forward of No. 3 axle.
F27	10	MB-1	10	Left tiedown fitting forward of No. 3 axle.
B28	10	MB-1	10	Right tiedown fitting forward of No. 3 axle.
F28	10	MB-1	10	Left tiedown fitting forward of No. 3 axle.
C29	10	MB-1	10	Right tiedown fitting aft of No. 2 axle.
E29	10	MB-1	10	Left tiedown fitting aft of No. 2 axle.
B38	10	MB-1	10	Right tiedown fitting forward of No. 1 axle.

Table 4-8. Tiedown Data for the M983, M977, and M985E1 in C-141B Aircraft (Fig 4-8)-Continued

Tiedown fitting		Tiedown Device		Attach to Item
Designation	Capacity in 1,000 lb	Type	Capacity in 1,000 lb	
C38	10	MB-1	10	Right tiedown fitting forward of No. 1 axle.
E38	10	MB-1	10	Left tiedown fitting forward of No. 1 axle.
F38	10	MB-1	10	Left tiedown fitting forward of No. 1 axle.
A41	25	MB-2	25	Right forward tiedown fitting.
G41	25	MB-2	25	Left forward tiedown fitting.
A42	25	MB-2	25	Right forward tiedown fitting.
G42	25	MB-2	25	Left forward tiedown fitting.

CAUTION

The M353 trailer with mounted items of the PATRIOT system and connected to the rear pintle of the 5-ton trucks will impact the aircraft near the ramp hinge. This action will occur when backing into or towing out of the C-141 aircraft.

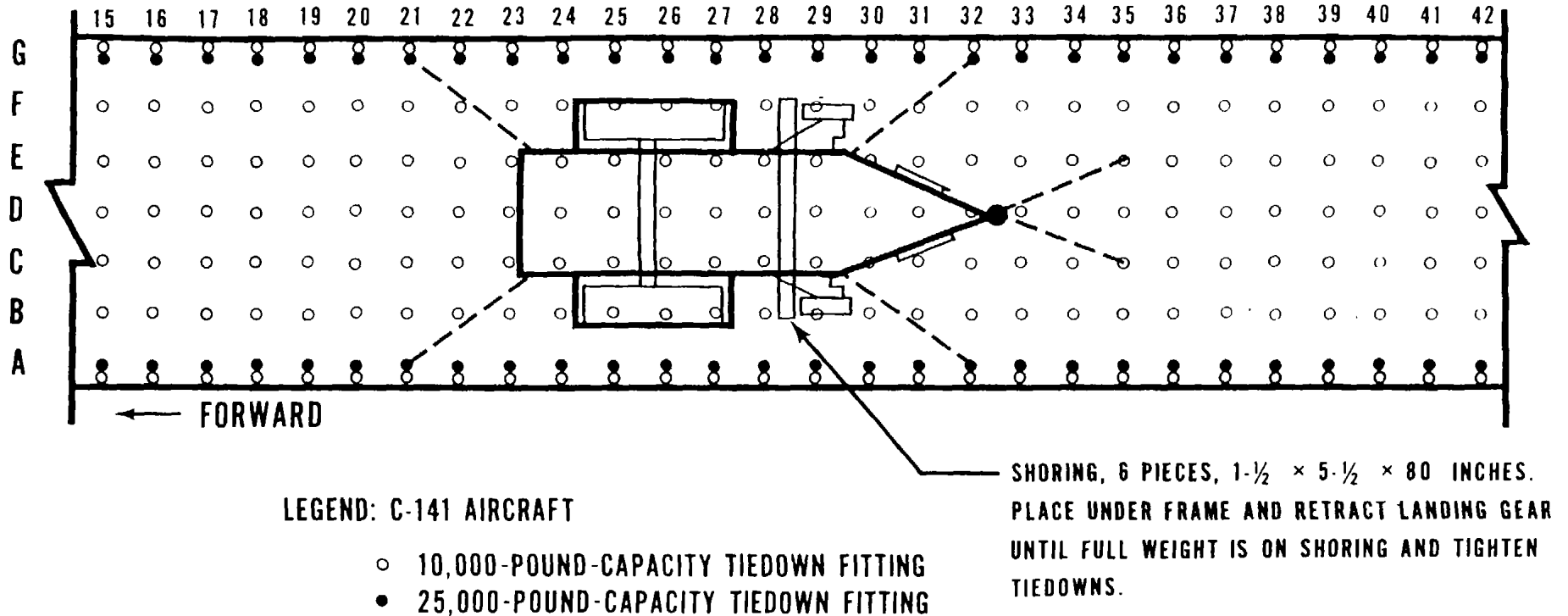

NOTE: FLOOR TIEDOWN FITTINGS ARE LOCATED IN ROWS A THROUGH G AND COLUMNS 1 THROUGH 56. THE RAMP HAS 6 ADDITIONAL COLUMNS. THIS IS A TYPICAL TIEDOWN PROCEDURE AND ONLY COLUMNS 15 THROUGH 42 ARE SHOWN. ITEM BEING SHIPPED CAN BE TIED DOWN AT ANY LOCATION APPROVED BY THE LOADMASTER.

Figure 4-9. Typical tiedown diagram for the PATRIOT trailer-mounted EPUs in C-141B aircraft.

d. Loading of the RS into the C-141B aircraft requires sectionalization into three major components. Loading of the M983 is as described in paragraph 4-7b and figure 4-8. The M860A1 semitrailer loading method is described in paragraph 4-7e. When removed from the M860A1, the RS shelter requires special support shoring to protect the outer azimuth bearing ring of the pedestal mount. Forward and aft supports for air transport are shown in figures 4-10 and 4-11. After stow locking the antenna, lift the RS (as shown in fig 65) from the M860A1 semitrailer. Place the support shoring 107.5 inches apart on three HCU-6/E pallets or on one 20-foot metric pallet. Place the RS on support shoring so it will face forward in the aircraft. Secure the RS with two tiedowns per pallet side to maintain alignment during loading. The pallet-loaded RS is transported to and loaded into the C-141B aircraft with either a 25K or 40K-loader. Position the aircraft ramp even with the aircraft floor. Then, align loader with aircraft ramp. Using two 25,000-pound chains from the MB-2 tiedown devices, form a towing bridle through the lower towing

rings on the RS. Attach the aircraft winch to the bridle, and winch load to its flight position the aircraft. Tie down the platform-loaded RS as shown in figure 4-12. Apply the tiedowns as shown in table 4-10.

Table 4-9. Tiedown Data for the M353 or M200A1 Trailer-Mounted EPUs in C-141B Aircraft (Fig 4-9)

Tiedown fitting		Tiedown Device		Attach to Item
Designation	Capacity in 1,000 lb	Type	Capacity in 1,000 lb	
A21	10	MB-1	10	Right rear tiedown fitting.
G21	10	MB-1	10	Left rear tiedown fitting.
A32	10	MB-1	10	Right forward tiedown fitting.
G32	10	MB-1	10	Left forward tiedown fitting.
C35	10	MB-1	10	Lunette.
E35	10	MB-1	10	Lunette.

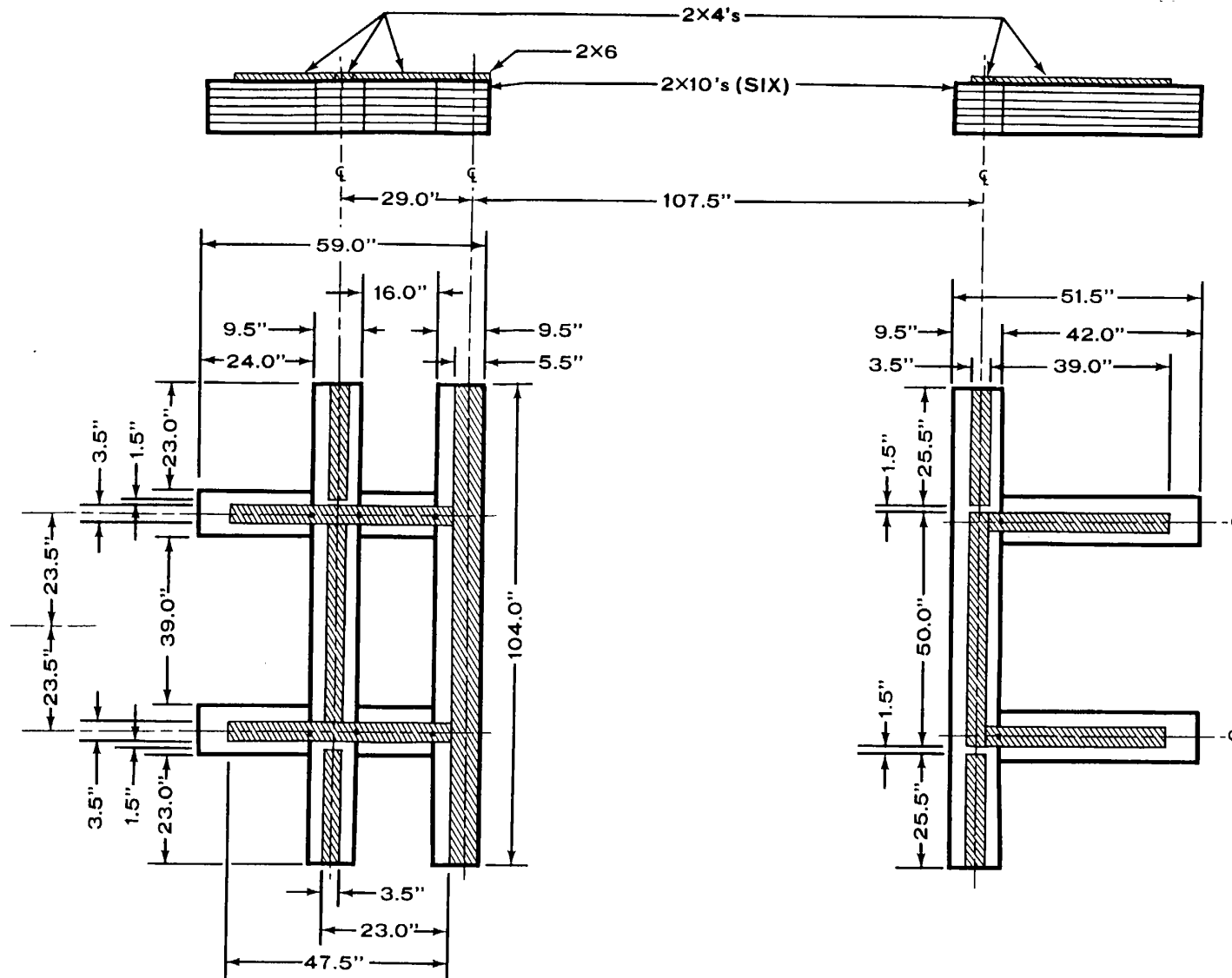

Figure 4-10. Support shoring assemblies required for pallet/platform loading the RS for transport in C-141B aircraft.

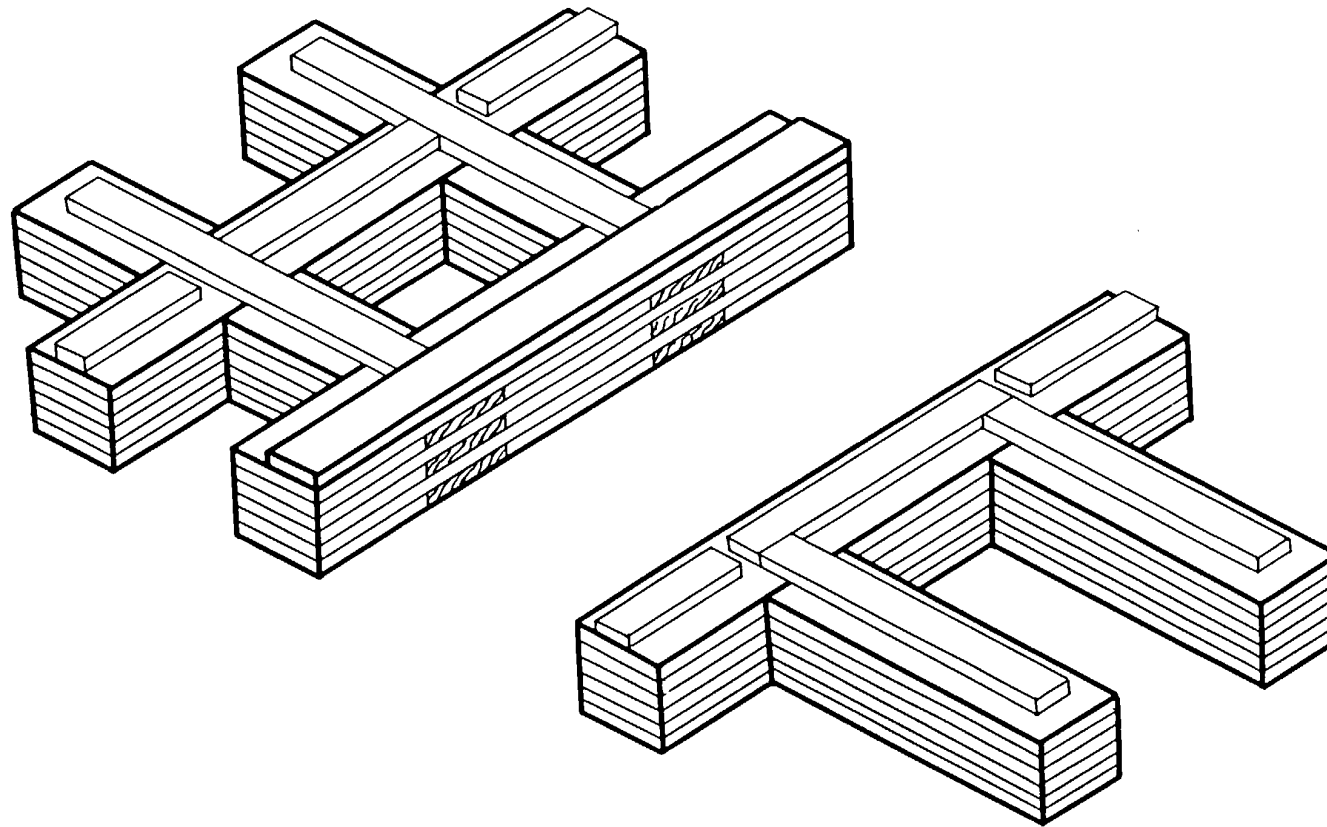
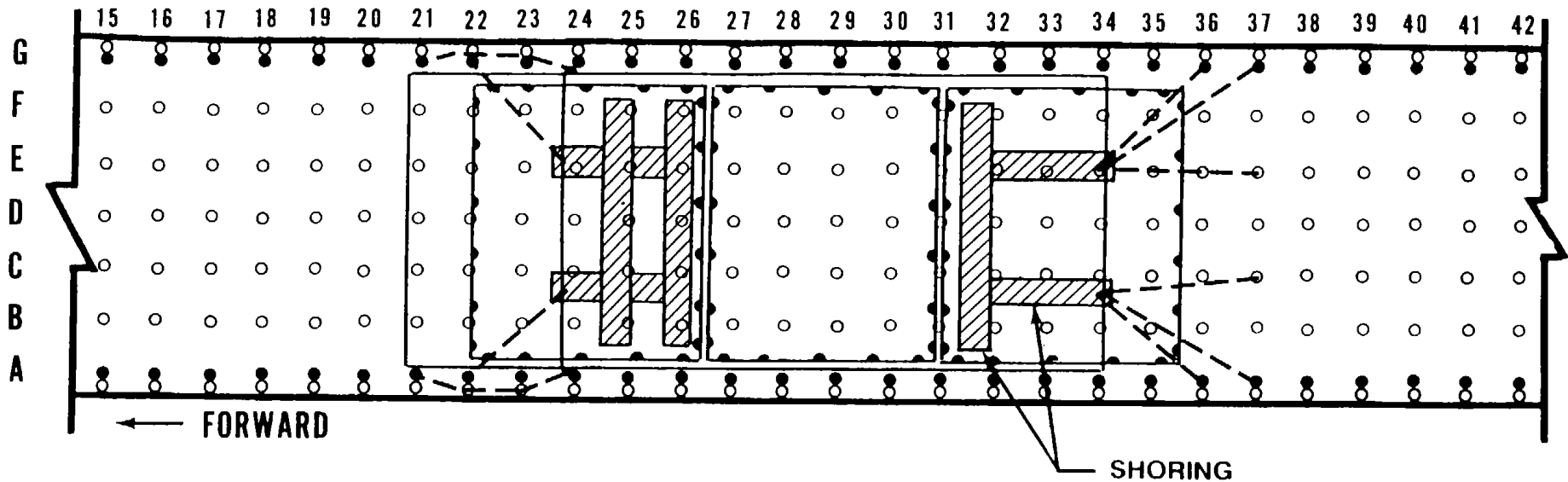

Figure 4-11. Three-quarters view showing assembled shoring for pallet/platform loading of the RS for air transport.



LEGEND: C-141 AIRCRAFT

- 10,000-POUND-CAPACITY TIEDOWN FITTING
- 25,000-POUND-CAPACITY TIEDOWN FITTING

NOTE: FLOOR TIEDOWN FITTINGS ARE LOCATED IN ROWS A THROUGH G AND COLUMNS 1 THROUGH 56. THE RAMP HAS 6 ADDITIONAL COLUMNS. THIS IS A TYPICAL TIEDOWN PROCEDURE AND ONLY COLUMNS 15 THROUGH 42 ARE SHOWN. ITEM BEING SHIPPED CAN BE TIED DOWN AT ANY LOCATION APPROVED BY THE LOADMASTER.

Figure 4-12. Tiedown diagram for the pallet/platform-loaded RS in C-141B aircraft.

e. The M860A1 semitrailer for the RS, with outrigger assemblies removed and secured on the semitrailer, is backed into the C-141B using the reduced M983. Before disconnecting the M983, place shoring beneath the landing gear. Build a stanchion using 4by 4-inch lumber-for vertical pieces and 2by 4-inch lumber for bracings under the kingpin area. Drive long tapered wedges snug between the top of the stanchion and fifth wheel plate. Secure wedges by toenailing. Tie down

the M860A1 semitrailer as shown in figure 4-13, and apply the tiedowns as shown in table 4-11. Reduce the M860A1 semitrailer for the LS by removing the outrigger assemblies and the electrical power unit (mounted on the gooseneck of the semitrailer). Load and secure the removed components to an HCU-6/E pallet as shown in figures 4-14 and 4-15 and tables 4-12 and 4-13. To load and tie down the M860A1 semitrailer for the LS, follow the same procedure as the M860A1 semitrailer for the RS.

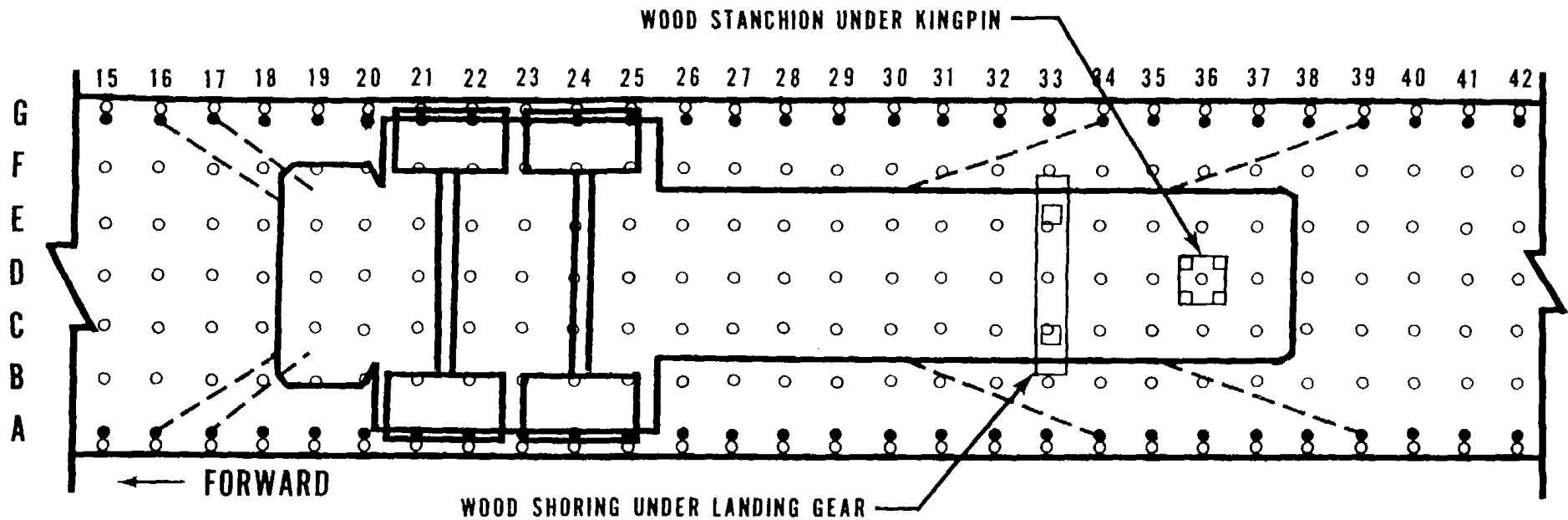

LEGEND: C-141 AIRCRAFT

- 10,000-POUND-CAPACITY TIEDOWN FITTING
- 25,000-POUND-CAPACITY TIEDOWN FITTING

NOTE: FLOOR TIEDOWN FITTINGS ARE LOCATED IN ROWS A THROUGH G AND COLUMNS 1 THROUGH 56. THE RAMP HAS 6 ADDITIONAL COLUMNS. THIS IS A TYPICAL TIEDOWN PROCEDURE AND ONLY COLUMNS 15 THROUGH 42 ARE SHOWN. ITEM BEING SHIPPED CAN BE TIED DOWN AT ANY LOCATION APPROVED BY THE LOADMASTER.

Figure 4-13. Tiedown diagram for the M860A1 semitrailer in C-141B aircraft.

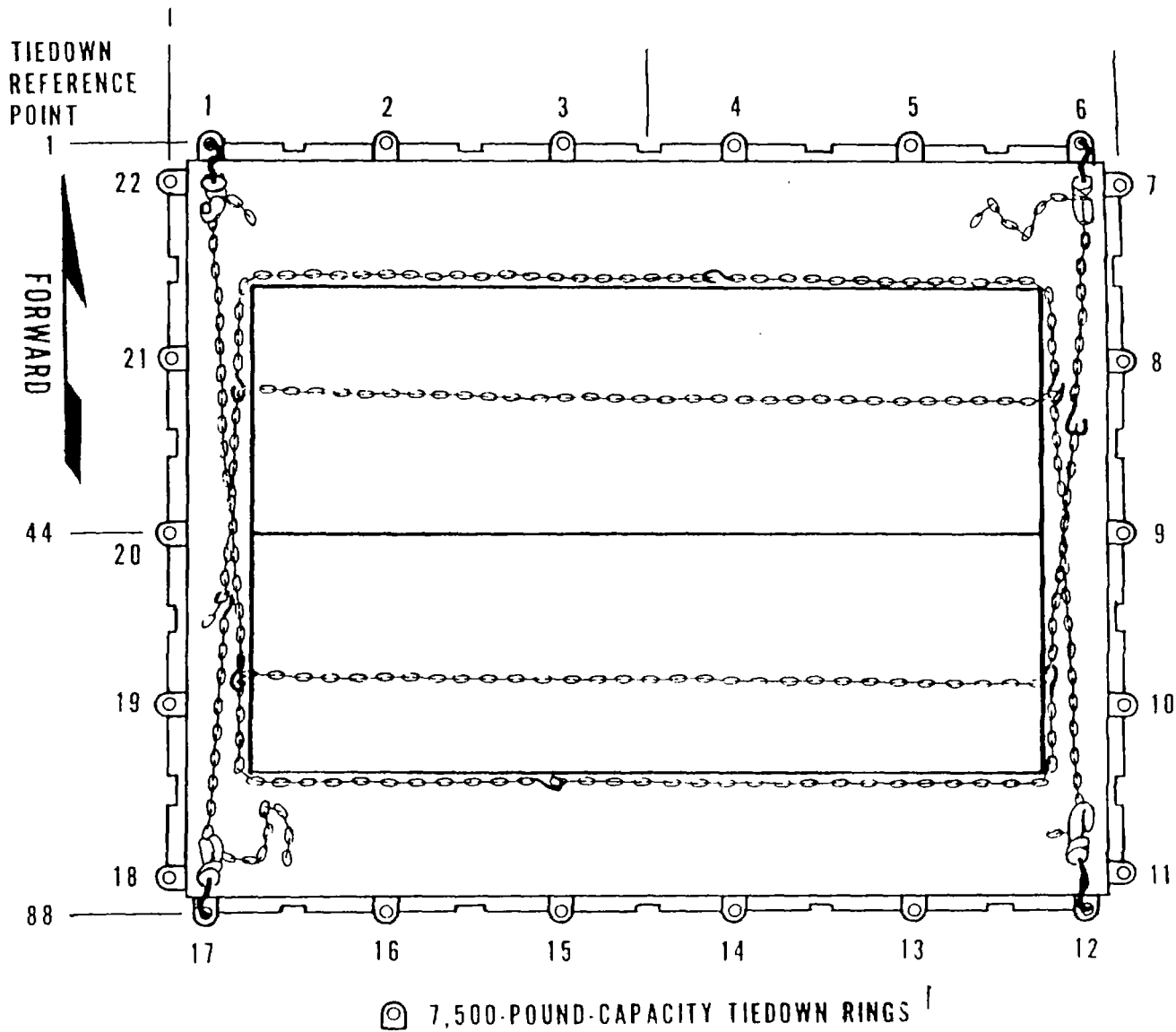

Figure 4-14. Four LS outriggers packaged, unitized, and secured to one HCU-6/E pallet.

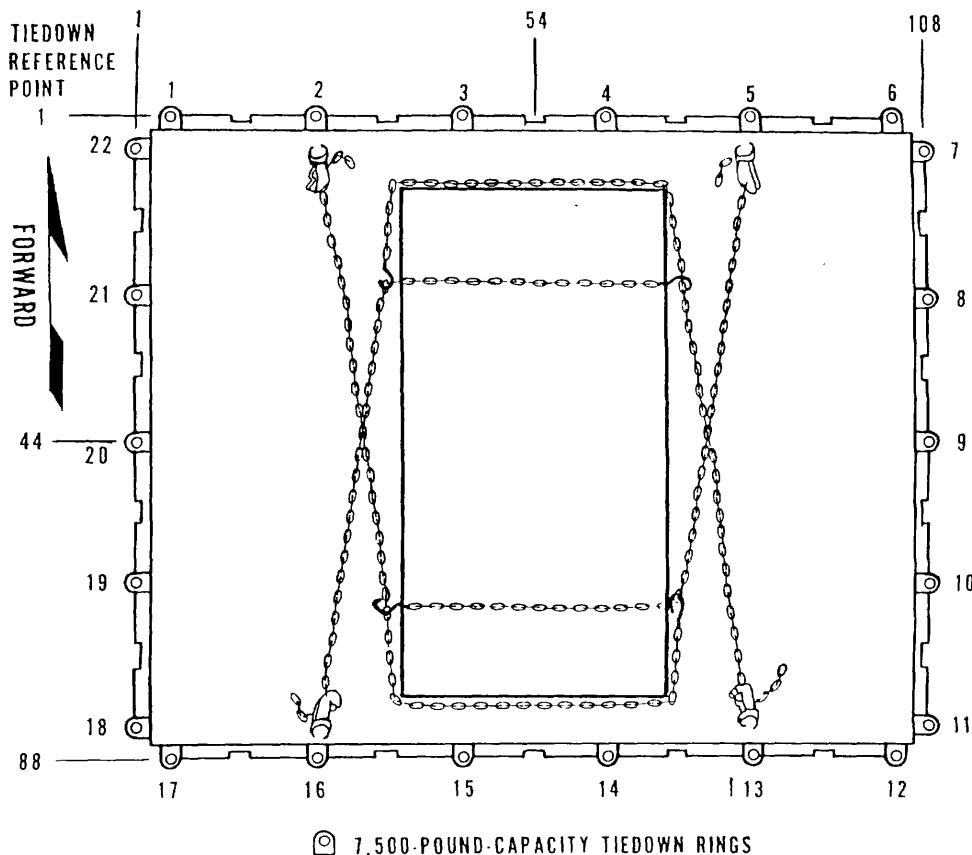

Figure 4-15. LS electrical power unit secured to one HCU-6/E pallet

Table 4-10. Tiedown Data for the Pallet/Platform-Loaded RS in C-141B Aircraft (Fig 4-12)

Tiedown fitting		Tiedown Device		Attach to Item
Designation	Capacity in 1,000 lb	Type	Capacity in 1,000 lb	
G21	25	MB-2	25	Upper right front tiedown fitting.
A21	25	MB-2	25	Upper left front tiedown fitting.
G22	25	MB-2	25	Lower right front tiedown fitting.
A22	25	MB-2	25	Lower left front tiedown fitting.

Table 4-10. Tiedown Data for the Pallet/Platform-Loaded RS in C-141B Aircraft (Fig 4-12) - Continued

Tiedown fitting		Tiedown Device		Attach to Item
Designation	Capacity in 1,000 lb	Type	Capacity in 1,000 lb	
G36	25	MB-2	25	Lower right rear tiedown fitting.
A36	25	MB-2	25	Lower left rear tiedown fitting.
G37	25	MB-2	25	Upper right rear tiedown fitting.
A37	25	MB-2	25	Upper left rear tiedown fitting.

Table 4-10. Tiedown Data for the Pallet/Platform-Loaded RS in C-141B Aircraft (Fig 4-12)-Continued

Tiedown fitting		Tiedown Device		Attach to Item
Designation	Capacity in 1,000 lb	Type	Capacity in 1,000 lb	
E37	10	MB-1	10	Upper right rear tiedown fitting.
C37	10	MB-1	10	Upper left rear tiedown fitting.

Table 4-11. Tiedown Data for M860AI Semitrailer in C-141B Aircraft (Fig 4-13)

Tiedown fitting		Tiedown Device		Attach to Item
Designation	Capacity in 1,000 lb	Type	Capacity in 1,000 lb	
A16	25	MB-2	25	Right bottom rear tiedown fitting.
G16	25	MB-2	25	Left bottom rear tiedown fitting.
A17	10	MB-1	10	Right upper rear tiedown fitting.
G17	10	MB-1	10	Left upper rear tiedown fitting.
A34	25	MB-2	25	Right midframe tiedown fitting.
G34	25	MB-2	25	Left midframe tiedown fitting.
A39	25	MB-2	25	Right gooseneck tiedown fitting.
G39	25	MB-2	25	Left gooseneck tiedown fitting.

Table 4-12. Tiedown Data for the RS/LS Outriggers Secured on One 463L Pallet (Fig 4-14)

Tiedown fitting		Tiedown Device		Attach to Item
Designation	Capacity in 1,000 lb	Type	Capacity in 1,000 lb	
1*	7.5	MB-1	10	Over top front and hook to 6.
6*	7.5	MB-1	10	Around front and hook to 1.
12*	7.5	MB-1	10	Over top rear and hook to 17.
17*	7.5	MB-1	10	Around rear and hook to 12.

*Link two chains together.

Table 4-13. Tiedown Data for the LS Electrical Power Unit on One 463L Pallet (Fig 4-15)

Tiedown fitting		Tiedown Device		Attach to Item
Designation	Capacity in 1,000 lb	Type	Capacity in 1,000 lb	
2	7.5	MB-1	10	Over top front and hook to 5.
5	7.5	MB-1	10	Around front and hook to 2.
13	7.5	MB-1	10	Over top rear and hook to 16.
16	7.5	MB-1	10	Around rear and hook to 13.

CHAPTER 5 HIGHWAY TRANSPORTABILITY GUIDANCE

Section I. GENERAL

5-1. Scope

This chapter provides highway transportability guidance for movement of the PATRIOT system. It covers technical and physical characteristics of and safety considerations for the PATRIOT. It also prescribes the materials and guidance required to prepare, load, tie down, and unload the PATRIOT system components.

5-2. Safety

Besides those safety precautions in chapter 3, highway movement is subject to all safety laws, rules, and regulations applying to commercial carriers in the continental United States (CONUS).

Overseas movements are governed by theater regulations.

5-3. General

The PATRIOT system components are transportable under their own power for highway movement in CONUS and overseas areas. The vehicles and payloads separated may also be transported by semitrailers of adequate size and load capacity. The semitrailer van-mounted systems should not be transported by another semitrailer. These items should be highway transported in towaway configuration by commercial or military truck tractors.

Section II. SELF-PROPELLED MOVEMENT

5-4. US Highways

The width of the PATRIOT system RS, LS, ECS, and ICC exceeds legal limits of the interstate highways and those major highways designated by the Federal Highway Administration (FHWA) for vehicles 102 inches (2.59 m) wide. In States with legal widths of 96 inches, all 5ton truck-mounted or towed systems will also exceed width limits. The RS and LS also exceed gross vehicle weight limits in some States. Most restrictions can be resolved by permits. Where maximum permit limits are exceeded, certification as "essential to national defense" may be necessary. The procedures for obtaining permits in CONUS are outlined in AR 55162.

Europe. Movement credits and selective routing will be required for all movements in those areas. To obtain information pertaining to special permits and selective routing, contact: Commander, 1st Transportation Movement Control Agency, ATTN: AEUTR-MCA-TA, APO New York, 09451-4000. For theater or incountry clearance, assistance can be obtained from the 4th Transportation Command, Oberursel, Germany.

5-5. European Highways

Most PATRIOT system components exceed width, gross weight, and tandem axle loads in countries throughout

5-6. Other Countries

The PATRIOT system will encounter similar restrictions to those in Europe in most countries worldwide. Special permits and selective routing will be required to accomplish movement.

Section III. TRANSPORT BY SEMITRAILER

5-7. General

The PATRIOT system components, except semitrailer vans, are highway transportable by military or commercial semitrailers of adequate size and capacity. This section provides for moving a disabled vehicle or the PATRIOT system for administrative or logistical purposes. In CONUS and in overseas areas, permits will be required because size and weight limitations will be exceeded. One Army semitrailer that can transport unloaded PATRIOT trucks and tractors is the M872 towed by the M915 truck-tractor. Moving disabled PATRIOT M860A1 semitrailers will be restricted to a lowbed-type semitrailer such as the M870 or M747,

because of the PATRIOT semitrailer width, gross vehicle weight, and tandem axles weights.

WARNING

All loads, vehicles or shelters, with a high center of gravity tend to overturn at normal highway speeds. Drivers should exercise extreme caution before entering curves or inclined road conditions. Potholes or uneven pavement will also increase overturning possibilities.

5-8. Preparation for Transport

a. Preparation of the M985E1, M983, and M977 10-ton trucks for semitrailer transport includes the following procedures:

- (1) Secure all basic issue items (BII) to preclude damage en route.
- (2) Remove the spare tire, and secure it on the vehicle.
- (3) Reduce each vehicle to a cab height of 101 inches.
- (4) Remove and stow communication antennas.
- (5) Check tire pressure.
- (6) Fold and secure the HIAB 8108 crane in the cargo bed of the M985E1 in accordance with TM 9-2320-355-10 or TM 9-2320-279-10 and -34.

b. Preparation for transport of M942 chassis, M927, M928, M931, and M932 5-ton trucks and truck-tractors. Preparation of the PATRIOT 5-ton trucks and truck-tractors for semitrailer transport includes the following procedures.

- (1) Secure all basic issue items (BII) to preclude damage en route.
- (2) Reduce each vehicle to steering wheel height.
- (3) Remove and stow communication antennas.
- (4) Remove shelters or PATRIOT components, and transport as a separate item.

c. Preparation for transport of the M860A1 semitrailer for the RS and LS, and the M353 trailer for the EPU, includes the following procedures:

- (1) Remove the RS from the M860A1.
- (2) Remove the outriggers on M860A1 semitrailers and secure to the semitrailer.
- (3) Remove the generator on the gooseneck of the M860A1 semitrailer for the LS.
- (4) Prepare removed generator to be shipped as a separate load.
- (5) Fully retract landing gear on M860A1 for the RS and LS.
- (6) Ensure all doors and access panels are in the closed position on the M353 trailer-mounted EPU.

5-9. Loading and Tiedown on Semitrailer

a. *Loading and Tiedown of the M985E1, M983, and M977 on Semitrailers.*

- (1) The M985E1, M983, and M977 may be driven onto the semitrailer by using suitable ramps or a loading deck. They may be lifted onto the semitrailer by a crane of adequate capacity, as described in paragraph 6-4b(1).
- (2) The bill of materials for blocking and tiedown of the M985E1, M983, and M977 on a semitrailer is shown in table 5-1. A blocking and tiedown diagram compatible with standard loading practices that will offer adequate restraint is provided in figure 5-1. Data concerning application of materials are provided in table 5-2.

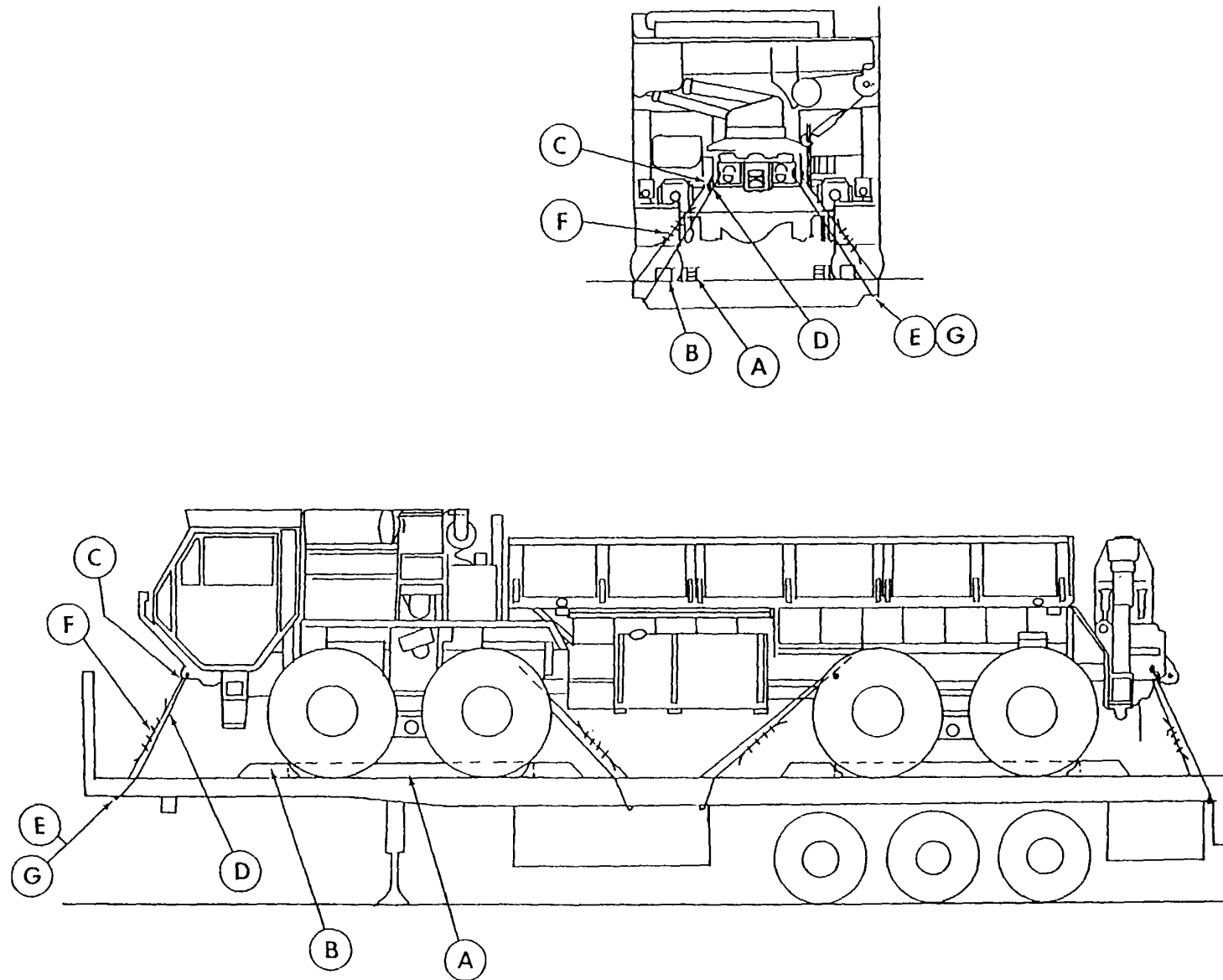

Figure 5-1. Blocking and tiedown diagram for the M985E1, M983, or M977 on an M872 semitrailer.

b. Loading and Tiedown of M942 Chassis, M927, M928, M931, and M932.

(1) The M942 chassis, M927, M928, M931, and M932 may be driven onto the semitrailer by using suitable ramps or a loading dock. They may also be lifted onto the semitrailer by a crane of adequate capacity as described in paragraph 6-4b(2).

(2) The bill of materials for blocking and tiedown of the 5-ton trucks and truck-tractors on a semitrailer is shown in table 5-3. Blocking and tiedown diagrams compatible with standard loading practices that will offer adequate restraint are provided in figures 5-2 through 5-4. Data concerning application of materials are provided in table 5-4.

Table 5-1. Bill of Materials for Blocking and Tiedown of the M985E1, M983, or M977 on an M872 Semitrailer (Fig 5-1)

Item	Description	Approximate Quantity
Lumber	Douglas-fir, or comparable; straight-grain, free from material defects; Fed Spec MML-751H: 6x 6-inch 2x 4-inch 2x 6-inch	12 linear feet 96 linear feet 32 linear feet
Nails	Common, steel, flathead; bright or cement-coated; table X1-b, Fed Spec FF-N-105: 40d 20d 16d	40 130 40
Wire rope.	6 x 19, IWRC; improved plow steel; performed, regular-lay; Fed Spec RR-W-410C: 5/8-inch.	90 feet
Clamps	Wire rope, U-bolt clips, saddled, single-grip, steel, Crosby heavy-duty, or equal; Fed Spec FF-C-450D: 5/8-inch 3/4-inch	32 8
Thimbles.	Standard, open-type, 5/8-inch	8
Shackles.	Anchor, screw pin; Type IV, Class I; Fed Spec RR-C-271B: 1 1/2-inch pin diameter); NSN 4030-00-169-9197 (required if vehicle shackle is missing).	4
Cushioning Material.	Waterproof, burlap, or other suitable material.	as required

Table 5-1. Bill of Materials for Blocking and Tiedown of the M985E1, M983, or M977 on an M872 Semitrailer (Fig 5-1)Continued

Item	Description	Approximate Quantity
Chains	Type 1, Grade C, Class 2; welded steel, 1/4to 1/2-inch-wide by 10-foot-long; 16,000-pound safe working load; welded steel, high-test chain; Fed Spec RR-C-271; with two grabhooks equal to or better than the strength of the chain.	8
Load binders.	Double-hook, heavy-duty, eccentric takeup, with chain grabhooks for 1/4- to 1/2-inch chain; 16,000-pound safe working load.	8

*Chains and load binders may be substituted for wire rope and clamps.

Table 5-2. Application of Materials for Blocking and Tiedown of the M985E1, M983, or M977 on an M872 Semitrailer (Fig 5-1)

Item	No. Required	Application
A	4	Side blocking. Each consists of one piece of 2- x 6- x 96-inch lumber and three pieces of 2- x 4- x 96-inch lumber. Nail the 2- x 6- x 96-inch piece to the side edge of a 2- x 4- x 96-inch piece with eight 16d nails. Place the 2x 6x 96inch piece against the cushioning material and tires, and nail the 2- x 4- x 96inch piece to the semitrailer with eight 20d nails. Place the second 2- x 4- x 96inch piece on top of the first and nail to the first 2- x 4- x 96-inch piece with eight 20d nails. Nail the third 2- x 4- x 96-inch in the same manner to the top of the second piece with eight 20d nails. Use a staggered nailing pattern to avoid striking the nails in the piece below.
B	8	Chock blocks, 6- x 6- x 18-inch lumber cut 45° at both ends. Place one block against the front of each tire of Nos. 1 and 3 axles and against the rear of each tire of Nos. 2 and 4 axles. Nail the heel of each block with three 40d nails. Toenail each side of each block to the semitrailer floor with two 20d nails.
C	4	Shackles. Place on shackle in each forward and rear tiedown point.
*D	8	Tiedown, 5/8-inch wire rope. Attach wire rope to form a complete loop from the shackle in the tiedown point or tiedown ring to the thimble (item E) in the semitrailer stake pocket. Tension tiedown evenly and apply item F.
*E	8	Thimbles, 5/8-inch. Place one thimble over the bottom edge of the semitrailer stake pocket.

Table 5-2. Application of Materials for Blocking and Tiedown of the M.985E1, M983, or M977 on an M872 Semitrailer (Fig 5-1)Continued No.

Item	No. Required	Application
*F	32	Clamps, 5/8-inch. Secure the ends of the wire rope at the overlap area with four clamps spaced 4 inches apart.
*G	8	Clamp, 3/4-inch. Secure item E to item D with one 3/4-inch clamp.

*Chains and load binders may be substituted for wire rope and clamps.

Table 5-3. Bill of Materials for Blocking and Tiedown of the 5Ton Truck or Truck-Tractor on an M872 Semitrailer (Figs 5-2 through 5-4)

Item	Description	Approximate Quantity
Lumber	Douglas-fir, or comparable; straight-grain, free from material defects; Fed Spec MML-751H: 6- x 6-inch 2- x 4-inch 2- x 6-inch	12 linear feet .72 linear feet 24 linear feet
Nails	Common, steel, flathead; bright or cement-coated; table X1-b, Fed Spec FF-N-105: 40d 20d 16d	.40 130 .40
*Wire rope.	6 x 19, IWRC; improved plow steel; performed, regular-lay; Fed Spec RR-W-410C: 1/2inch	45 feet
*Clamps	Wire rope, U-bolt clips, saddled, single-grip steel, Crosby heavy-duty or equal; Fed Spec FF-C-450D: 1/2-inch 5/8-inch	16 4
*Thimbles.	Standard, open-type, 1/2-inch	4
Cushioning material.	Waterproof, burlap, or other suitable material	as required
Chains	Type I, Grade C, Class 2; welded steel, 1/4- to 1/2-inch-wide by 10-foot-long; 16,000 pound safe working load; welded steel, high-test chain; Fed Spec RR-C-271; with two grabhooks equal to or better than the strength of the chain.	8
Load binders.	Double-hook, heavy-duty, eccentric takeup, with chain grabhooks for 1/4to 1/2-inch chain; 16,000-pound safe working load.	8

*Chains and load binders may be substituted for wire rope and clamps

Table 5-4. Application of Materials for Blocking and Tiedown of the 5-Ton Truck or Truck-Tractor on an M872 Semitrailer (Figs 5-2 Through 5-4)

Item	No. Required	Application
A	6	Chock blocks, 6- x 6- x 18-inch lumber cut 45° at both ends. Place one block against the front and back of each front tire, and against the front inside tire of No. 2 axle and against the rear inside tire of No. 3 axle. Nail the heel of each block with three 40d nails. Toenail each side of each block to the semitrailer floor with two 20d nails.
B	4	Side blocking. Two rear blocks consist of one piece of 2- x 6- x 96 inch lumber and three pieces of 2- x 4- x 96-inch lumber. Nail the 2- x 6- x 96inch piece to the side edge of a 2- x 4- x 96-inch piece with eight 16d nails. Place the 2- x 6- x 96-inch piece against the cushioning material (item C) and tires and nail the 2- x 4- x 96-inch piece to the 4 semitrailer with eight 20d nails. Place the second 2- x 4- x 96-inch piece on top of the first and nail to the first 2- x 4- x 96-inch piece with eight 20d nails. Nail the third 2- x 4- x 96-inch piece in the same manner to the top of the second piece with eight 20d nails. Use a staggered nailing pattern to avoid striking the nails in the piece below. The two forward blocks are 48 inches long and placed as described above.
C	as required	Cushioning material. Place between tire and item B.
*D	4	Tiedown, 1/2-inch wire rope. Attach wire rope to form a complete loop from the shackle in the tiedown point or tiedown ring to the thimble (item E) in the semitrailer stake pocket. Tension tiedown evenly and apply item F.
*E	4	Thimbles, 1/2-inch. Place one thimble over the bottom edge of the semitrailer stake pocket.
*F	16	Clamps, 1/2-inch. Secure the ends of the wire rope at the overlay area with four clamps spaced 4 inches apart.
*G	4	Clamp, 5/8-inch. Secure item E to item D with one 5/8-inch clamp.

*Chains and load binders may be substituted for wire rope and clamps.

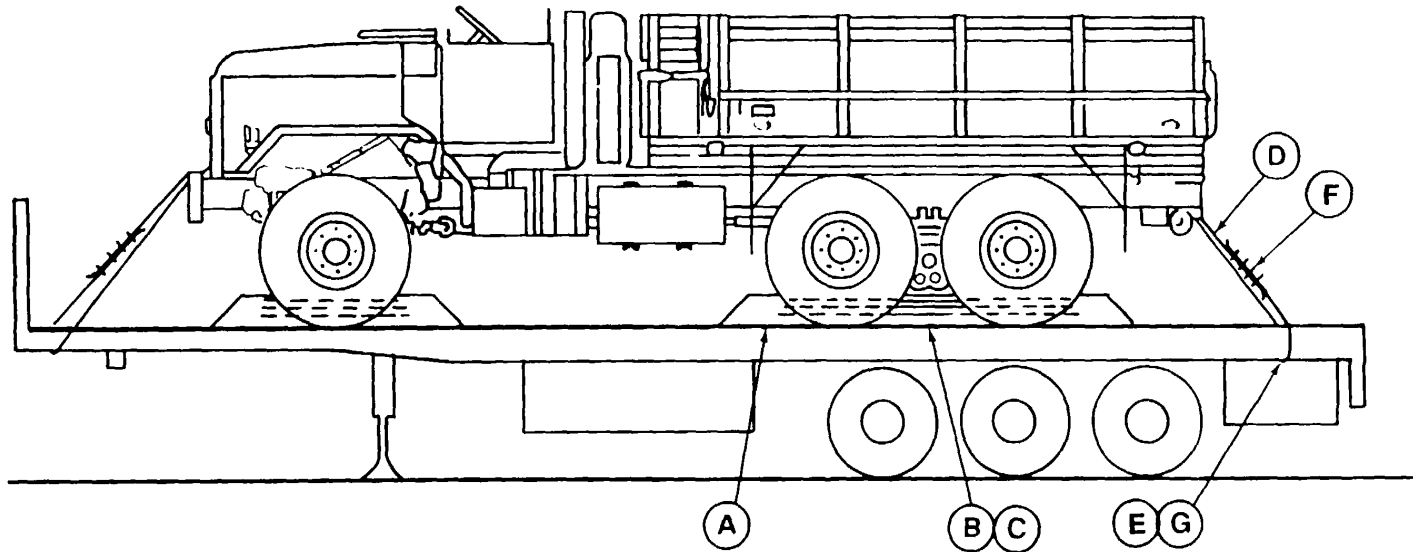

Figure 5-2. Blocking and tiedown diagram for the M942 chassis and the M927, M928, M931, <932 trucks and truck-tractors on an M872 semitrailer (side).

c. *Loading and Tiedown of the M860A1 Semitrailer on the M870 Semitrailer.* The M860A1 semitrailer in its reduced configuration, with landing gear fully retracted, should be lifted into its tiedown position on the M870 semitrailer. Tie down

the M860A1 as shown in figures 5-5 and 5-6. Tables 5-5 and 5-6, bill of and application of materials for blocking and tiedown, are used with figures 5-5 and 5-6.

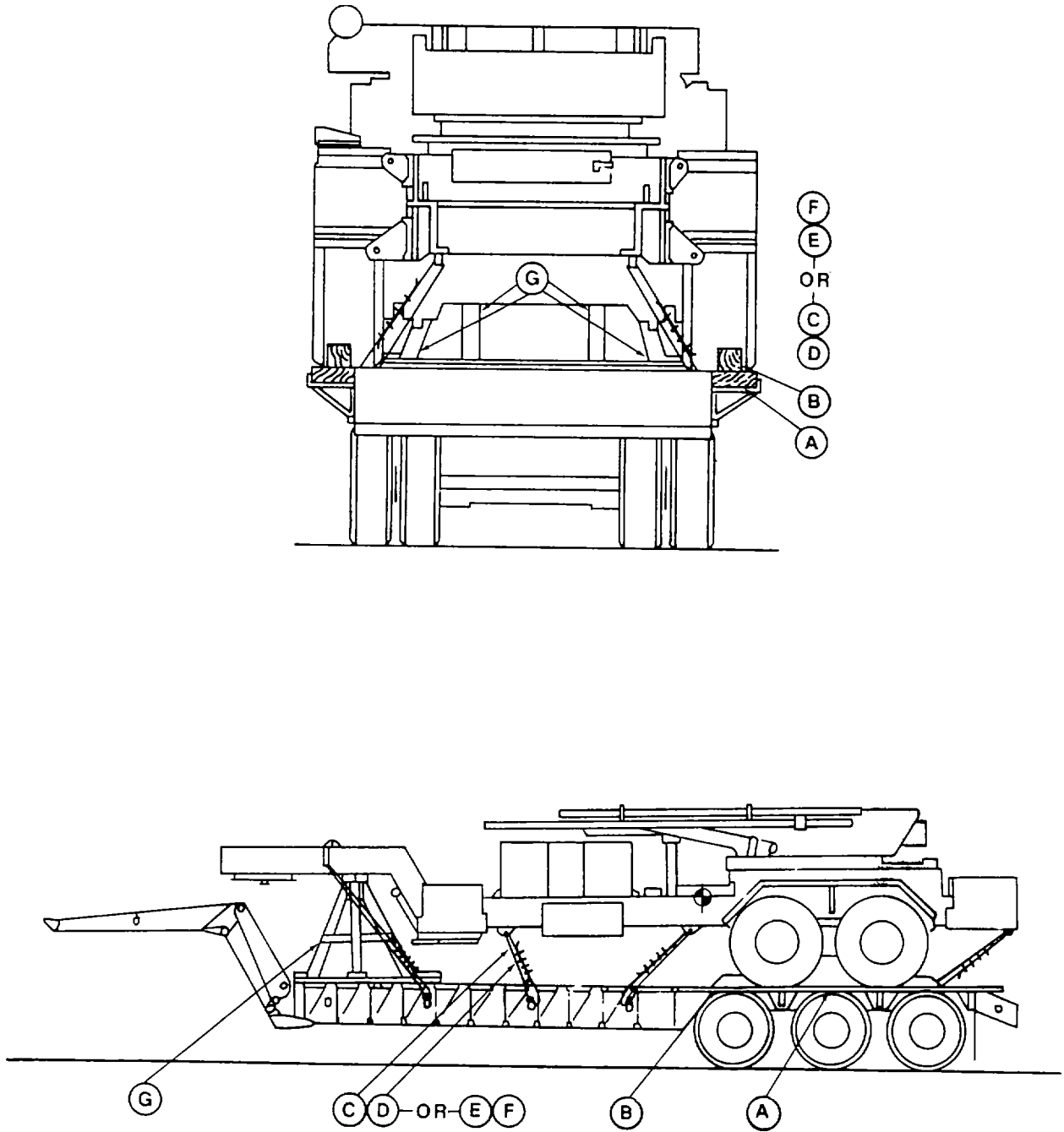

Figure 5-5. Side and rear views of blocking and tiedown of th M860A1 semitrailer on an M870 semitrailer.

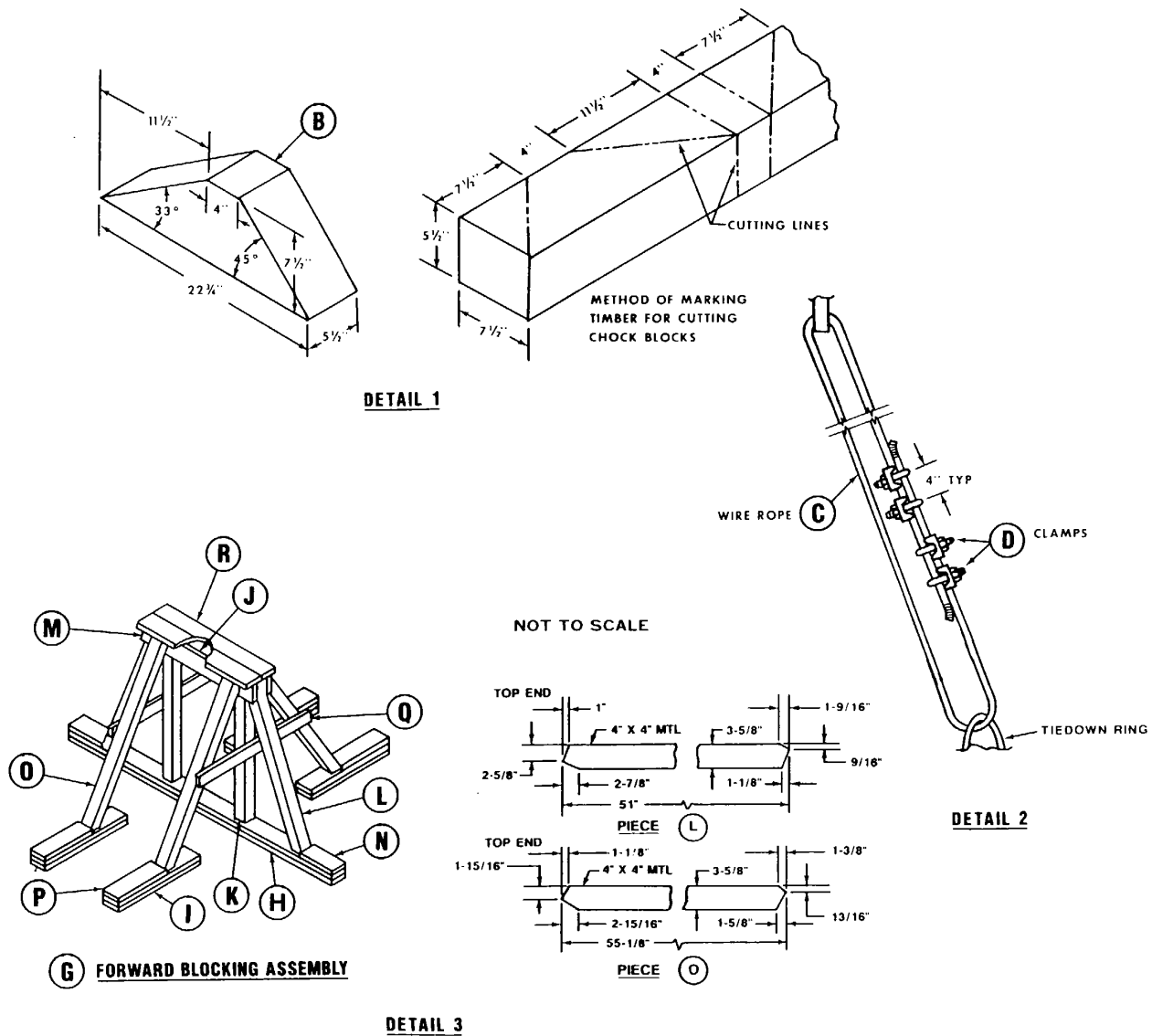

Figure 5-6. Blocking and tiedown details for M860A1 semitrailer.

d. *EPUs and Refueling Units Mounted on Trailers.*
 EPUs and refueling units mounted on single axle trailers may be transported by commercial and military semitrailers of adequate size and weight capacity. Trailer-mounted items may be placed on the semitrailer by a crane or from a loading ramp. Fuel trailers will normally be transported empty with the tank purged. After placement of the trailers at the tiedown position, secure them in accordance with figures 5-7 and 5-8. After the lunette and frame of the trailers are placed on the forward blocking assembly, retract the M353 forward swivel castors and the M200A1 landing gear. Tables 5-7 and 5-8, bill and application of materials for blocking and tiedown, are used with figures 5-7 and 5-8.

Table 5-5. Bill of Materials for Blocking and Tiedown of the M860A1 on an M8700 Semitrailer (Fig. 5-5 and 5-6)

Item	Description	Approximate Quantity
Lumber	Douglas-fir, or comparable; straight-grain, free from material defects; Fed Spec MM-L-751C:	
	2- x 4-inch	45 linear feet
	2- x 6-inch	64 linear feet
	4- x 4-inch	38 linear feet
	6- x 8-inch	6 linear feet
Nails	Common, steel; flathead; bright or cement-coated; table X1-b, Fed Spec FF-N-105A:	
	12d	78
	16d	48
	20d	48
	30d	160
	40d	20
	50d	99
* Wire rope.	6 x 19, IWRC; improved plow steel; performed, regular-lay; Fed Spec RR-W-410C: 1/2-inch.	150 feet
* Clamps	Wire rope, U-bolt clips, saddled, single-grip, steel, Crosby heavy-duty, or equal; Fed Spec FF-C-450D: 1/2-inch.	32
Chain	General service, S-leg, alloy steel, 1/4- to 1/2-inch size, 10-foot length, with two grabhooks.	8
Load binder.	Lever-operated, 4-inch takeup with two grabhooks designed for 1/4- to 1/2-inch chain, 18-1/2-inch lever, large, 4-ton capacity, OD finish; MIL-B-1816 (NSN 3990-00-274-6746).	8

*Chains and load binders may be substituted for wire rope and clamps.

Table 5-6. Application of Materials for Blocking and Tiedown of the M860A1 on an M870 Semitrailer (Figs 5-5 and 5-6)

Item	No. Required	Application
A	outrigger boards	Relocate the two rear outrigger boards from their center stored location to the extended outriggers. Place front end of boards 12 inches in front of last swingout outrigger. Place M860A1 wheels above and between wheel supports of M870. See figure 5-5 for general location.
B	4	Chock blocks (detail 1, fig 5-6). Locate 45°, portion of block against front of front tire and rear of rear tires of M860A1. Nail heel of block to outrigger board with three 40d nails, and toenail that portion of the block under tire to outrigger board with two 40d nails before applying items D and C.
*C	8	Tiedown, 1/2-inch wire rope. Attach wire rope to form a complete loop from the tiedown provision on the M860A1 to the tiedown ring on the M870 (detail 2, fig 5-6). Ends of wire rope should overlap about 24 inches.
*D	32	Clamps, 1/2-inch wire rope. Place four clamps on each item C at the overlap area. Space clamps 4 inches apart and 6 inches from ends of wire rope.
E	8	Chain, general service, S-leg, alloy steel, 1/4- to 1/2-inch size, 10-foot length, with two grabhooks. Pass one end of chain through tiedown shackles at each point on vehicle and engage grabhooks on convenient chain link. Pass other end of chains through tiedown fitting on same side of semitrailer forming a 45° angle.
F	8	Load binder, lever-operated, 4-inch takeup, with two grabhooks designed for 1/4- or 1/2-inch chain. Engage one grabhook into link of chain coming from vehicle securement points. Pull chain through semitrailer tiedown fitting and engage other grabhook into a convenient link. Pull lever down, and lock into secured position. A piece of pipe may be required to depress level in locking position to ensure sufficient depression on vehicle tires. Do not install items E and F until G is in place and the M860A1 landing gear is fully retracted.
G	1	<i>For items H through R, below, refer to forward blocking assembly detail (detail 3, fig 5-6).</i>

Table 5-6. Application of Materials for Blocking and Tiedown of the M860A1 on an M870 Semitrailer (Figs 5-5 and 5-6)Continued

Item	No. Required	Application
H	2	Lumber, 2- x 6- x 96-inch. Nail to floor with one 30d nail every 8 inches in vicinity under the gooseneck, rear of the M860A1 kingpin area. See figure 5-5 for location. Nail second piece on top of first piece in like manner.
I	8	Lumber, 2- 6- 24-inch. Nail to floor with six 30d nails, 33 inches apart, centered on width of semitrailer and with the ends 11 inches from item H. Nail a second piece on top of first in like manner with staggered nailing pattern so as not to strike nails in first piece.
J	1	Lumber, 4- x 4- x 40-inch.
K	2	Lumber, 4- x 4- x 43 1/2-inch. Toenail flush with the ends of item J with four 16d nails. Invert and place on item H, in line with item I, and toenail with four 16d nails.
L	2	Lumber, 4- x 4- x 51-inch. Double bevel each end as shown in piece L, detail 3, figure 5-6. Toenail to items H and J with two 16d nails at each end.

Table 5-6. Application of Materials for Blocking and Tiedown of the M860A1 on an M870 Semitrailer (Figs 5-5 and 5-6)Continued

Item	No. Required	Application
M	2	Lumber, 2- x 6- x 48-inch. Nail to J with six 12d nails and to K and L with two 12d nails each.
N	2	Lumber, 2- x 6- x 14-inch. Tap firmly against item L and nail to item H with four 30d nails.
O	4	Lumber, 4- x 4- x 55 1/8-inch. Double bevel each end as shown in piece O, detail 3, figure 5-6. Toenail to items M and I with two 16d nails at each end.
P	4	Lumber, 2- x 6- x 14-inch. Tap firmly against item O and nail to item I with four 30d nails.
Q	2	Lumber, 2- x 4- x 42-inch. Nail to items O and K with three 12d nails each.
R	2	Lumber, 2- x 6- x 48-inch. Center equally above all connecting pieces J, L, M, and O, and nail with two 16d nails in each of them and four 16d nails in staggered pattern in the middle portion of M and J.

*Chains and load binders may be substituted for wire rope and clamps.

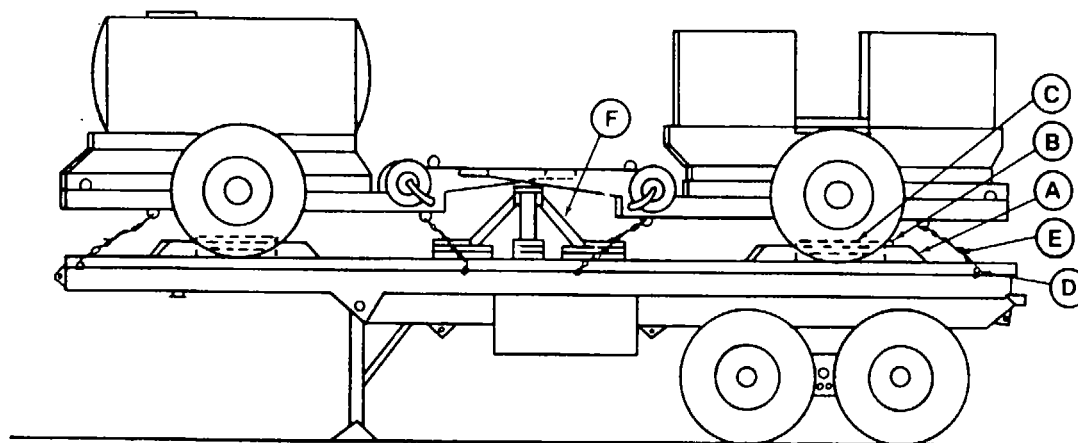
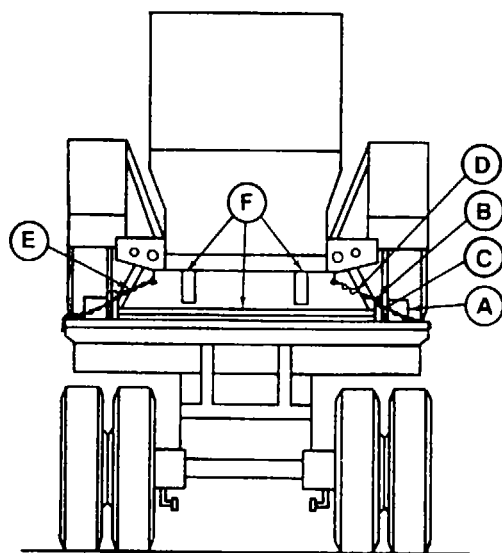

Figure 5-7. Blocking and tiedown of the PATRIOT trailers on an M127A1 semitrailer.

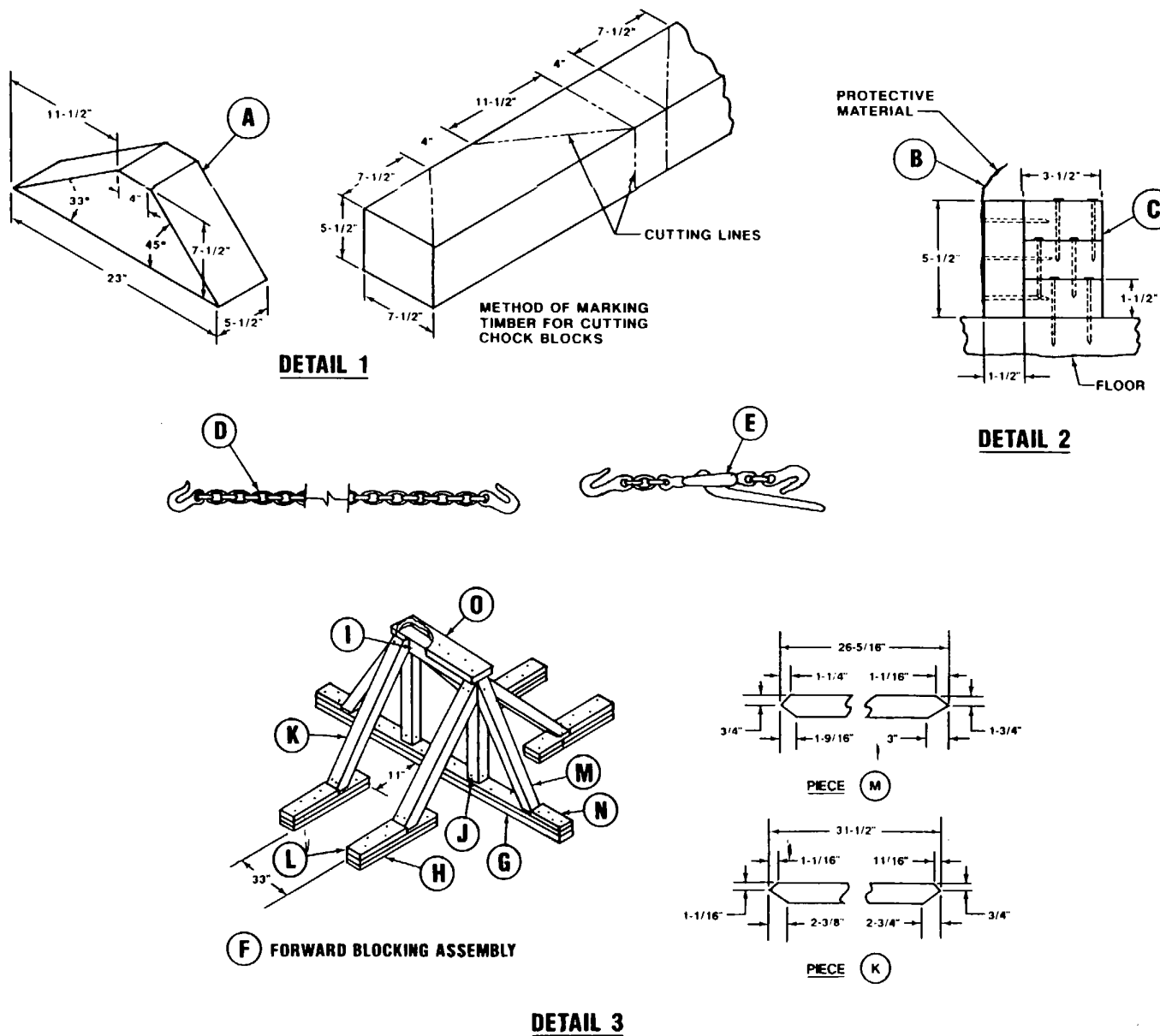

Figure 5-8. Blocking and tiedown details for the PATRIOT trailers.

e. **PATRIOT Shelter-Mounted Components.** PATRIOT shelter-mounted components may be transported on a number of commercial and military semitrailers of adequate length and weight capacity, such as the M269A1 or M270A1-series semitrailers. Semitrailer load bed heights may vary from as high as 60 inches to as low as 26 inches and restrictions may vary according to the semitrailer used. For example, when the RS is loaded on the M127 semitrailer, the overall height will be 161 inches, within the unrestricted CONUS legal height of 162 inches. The width of the loaded RS is 113 inches, and will require width permits for all moves. Typical semitrailer loading of PATRIOT shelter-mounted items, except the RS, is shown in figure 5-9. Bill and application of materials for blocking and tiedown are shown in tables 5-9 and 5-10, respectively. The RS with shoring assemblies detailed and loaded on a typical semitrailer is shown in figure 5-10. Stow lock antenna as shown in the figure. Bill and application of materials for blocking and tiedown are shown in tables 5-11 and 5-12, respectively. Shelters and the RS are lifted to their tiedown position as described in paragraph 6-4b(3).

Table 5-7. Bill of Materials for Blocking and Tiedown of the PATRIOT Trailers on Semitrailer(s) (Figs 5-7 and 5-8)

Item	Description	Approximate Quantity
Lumber	Douglas-fir, or comparable, straight-grain, free from material defects; Fed Spec MML-751C:	
	2- x 4-inch	35 linear feet
	2- x 6-inch	52 linear feet
	4- x 4-inch	26 linear feet
	6- x 8-inch	12 linear feet
Nails	Common, steel; flathead; bright or cement-coated; table X1-6, Fed Spec FF-N-105A:	
	16d	48
	20d	48
	30d	170
	40d	48
Cushioning material.	Waterproof paper, or suitable material.	as required
Chain	General service, S-leg, alloy steel, 1/4- to 1/2-inch size, 10-foot length, with two grabhooks.	8

Load binder. Lever-operated, 4-inch takeup with two grabhooks designed for 1/4- to 1/2-inch chain, 18 1/2-inch lever, large, 4-ton capacity, OD finish; MIL-B-1816 (NSN 3990-00-274-6746). 8

Table 5-8. Application of Materials for Blocking and Tiedown of the PATRIOT Trailers on Semitrailer(s) (Figs 5-7 and 5-8)

Item	No. Required	Application
A	8	Chock blocks (detail 1, fig 5-8). Locate 45 portion of block against front and rear of each wheel. Nail heel of block to floor with three 40d nails, and toenail that portion of the block under tire to floor with two 40d nails before applying items B and C.
B	as required	Protective material (detail 2, item B, fig 5-8), such as waterproof paper or burlap, should be placed under the bottom surface of 2- x 4- x 36-inch piece and between tire and 2- x 6- x 36-inch piece to extend 2 inches above blocking.
C	4	Side blocking (detail 2, item C, fig 5-8). Each to consist of one piece of 2- x 6- x 36-inch lumber and three pieces of 2- x 4- x 36-inch lumber. Nail 2- x 6- x 36-inch piece to edge of a 2- x 4- x 36-inch piece with five 20d nails. Place 2- x 6- x 36-inch piece against tire, and nail to semitrailer floor through 2- x 4- x 36-inch piece with five 20d nails in staggered pattern. Nail the other 2- x 4- x 36-inch pieces to one below in like manner with five 30d nails each.
D	8	Chain, general service, S-leg, alloy steel, 1/4- to 1/2-inch size, 10-foot length, with two grabhooks. Pass one end of chain through tiedown shackles at each end of vehicle and engage grabhooks on convenient chain link. Pass other end of chains through stake pockets on same side of semitrailer, forming a 45° angle.
E	8	Load binder, lever-operated, 4-inch takeup, with two grabhooks designed for 1/4- to 1/2- inch chain. Engage one grabhook into link of chain coming from vehicle securement points. Pull chain through stake pockets and engage with grabhook into a convenient link. Pull lever down, and lock into secured position. A piece of pipe may be required to depress lever in locking position to ensure sufficient depression on vehicle tires. Do not install items D and E until F is in place and trailer forward swivel castors are fully retracted.

Table 5-8. Application of Materials for Blocking and Tiedown of the PATRIOT Trailers on Semitrailer(s) (Figs 5-7 and 5-8)-Continued

Item	No. Required	Application
F	1	<i>For items F through O below, refer to forward blocking assembly detail (detail 3, fig 5-8).</i>
G	2	
H	8	Lumber, 2- x 6- x 96-inch. Nail to floor with one 30d nail every 8 inches in vicinity under the trailer lunette frames. See figure 5-7 for location. Nail second piece on top of first piece in like manner.
I	1	Lumber, 2- x 6- x 24-inch. Nail to floor with six 30d nails, 33 inches apart, centered on width of semitrailer and with the ends 11 inches from item G. Nail a second piece on top of first in like manner with staggered nailing pattern so as to not strike nails in first piece.
J	2	Lumber, 4- x 4- x 40-inch.
K	4	Lumber, 4- x 4- x 19-inch. Toenail flush to the ends of item J with four 16d nails. Invert and place on item G in line with item H and toenail with four 16d nails.
L	4	Lumber, 4- x 4- x 32-inch. Double-bevel each end as shown in piece K, detail 3, figure 5-8. Toenail to items H and I with two 16d nails at each end.
M	2	Lumber, 2- x 6- x 14-inch. Tap firmly against item K and nail to item H with four 30d nails.
N	2	Lumber, 4- x 4- x 27-inch. Double-bevel each end as shown in piece M, detail 3, figure 5-8. Toenail to items G and I with two 16d nails at each end.
O	1	Lumber, 2- x 6- x 14-inch. Tap firmly against item M and nail to item G with four 30d nails.
	1	Lumber, 2- x 6- x 44-inch. Center equally above all connecting pieces I, K, and M and nail with two 16d nails in each of them and with four 16d nails in staggered pattern in the middle portion of O and to item I.

Table 5-9. Bill of Materials for Blocking and Tiedown of the PATRIOT Shelter-Mounted Items, Except RS, on Semitrailers (Fig 5-9)-Continued

Item	Description	Approximate Quantity
Nails	Common, steel; flathead; bright or cement-coated; table X1-b, Fed Spec FF-N-105A: 20d.	96
Cushioning material.	Waterproof paper, or suitable material.	as required
Chain	General service, S-leg, alloy steel, 1/4- to 1/2-inch size, 10-foot length, with two grabhooks.	8
Load binder.	Lever-operated, 4-inch takeup, with two grabhooks designed for 1/4- to 1/2-inch chain, 18 1/2-inch lever, large, 4-ton capacity, OD finish; MIL-B-1816 (NSN 3990-00-274-6746).	8

Table 5-10. Application of Materials for Blocking and Tiedown of PATRIOT Shelter-Mounted Items, Except RS, on Semitrailers (Fig 5-9)

Item	No. Required	Application
A	2	Chain, general service, S-leg, alloy steel, 1/4- to 1/2-inch size, 10-foot length with two grabhooks. Pass one end of chain through tiedown fitting at the top left rear corner of shelter and engage grabhooks on a convenient chain link. Pass other end through stake pocket on same side of semitrailer, forming a 60° angle. Repeat for top right rear corner of shelter.
B	6	Chain as in A and attach at the remaining six corners and cross each to opposite side of semitrailer, forming 45° angle.
C	8	Load binder, lever-operated, 4-inch takeup, with two grabhooks designed for 1/4- or 1/2-inch chain. Engage on grabhook into link of chain coming from tiedown fitting. Pull chain through stake pocket and engage other grabhook into a convenient link. Do not over-tension chains; adjust grabhook to next link to achieve proper tension. Pull lever down and lock into secured position.
D	6	End blocking. Each consists of three pieces of 2- x 6- x 48-inch lumber. Place one stack against each skid on both ends of the shelter. Nail the first piece against the skid with ten 20d nails. Nail the top two pieces in same manner.

Table 5-9. Bill of Materials for Blocking and Tiedown of the PATRIOT Shelter-Mounted Items, Except RS, on Semitrailers (Fig 5-9)

Item	Description	Approximate Quantity
Lumber	Douglas-fir, or comparable, straight-grain, free from material defects; Fed Spec MML-751C: 2- x 6-inch.	76 linear feet

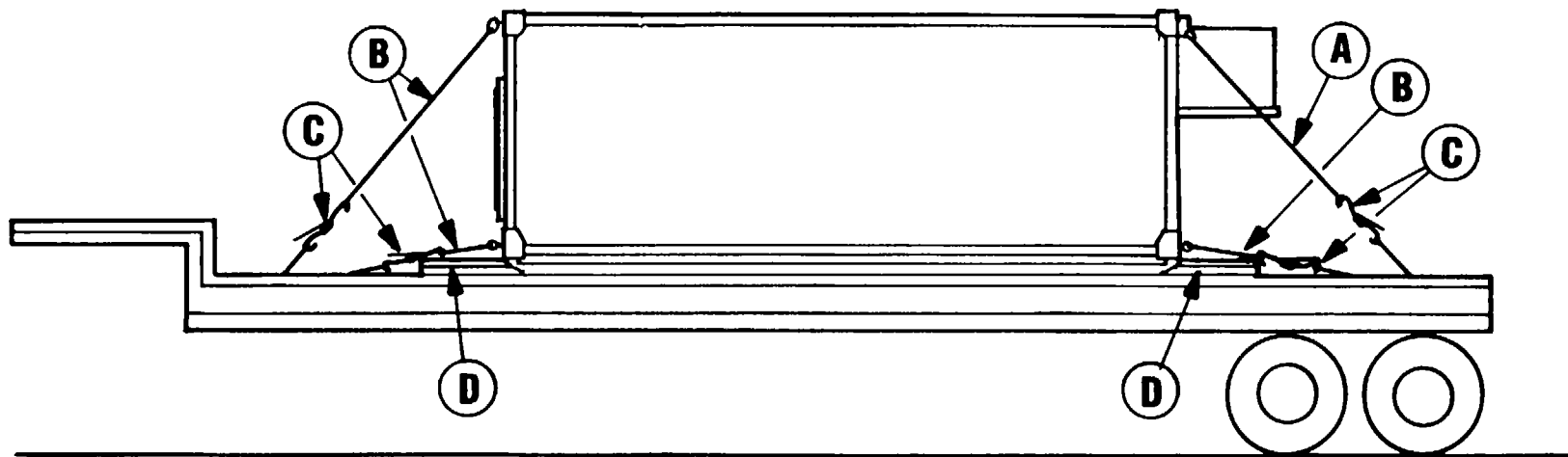

Figure 5-9. Blocking and tiedown of the PATRIOT shelter-mounted ECS, ICC, MC (Con), or CRG on an M269A1 or M270A1

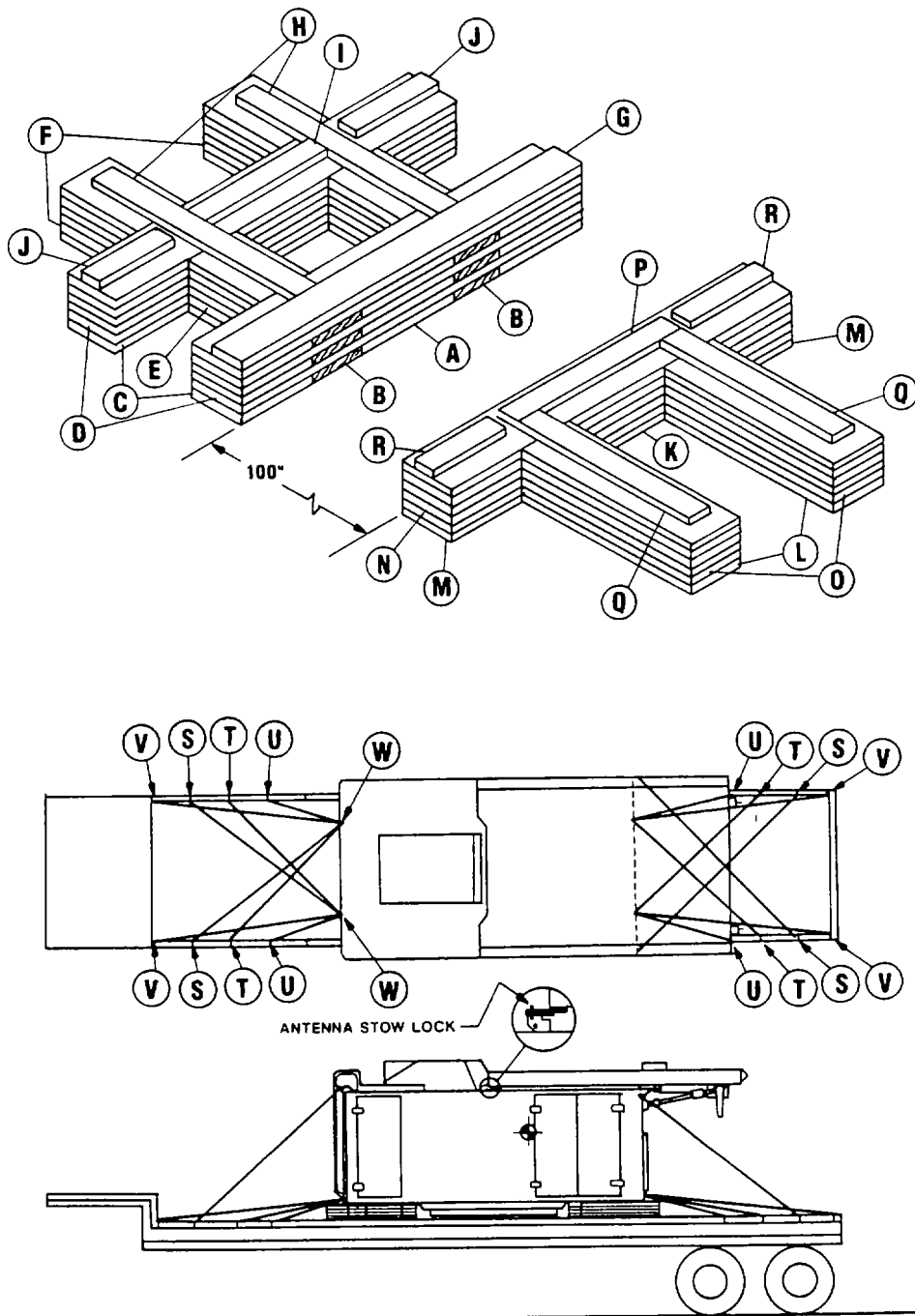

Figure 5-10. Blocking and tiedown of the RS on an M269A1 or M270A1 semitrailer.

f. *PATRIOT Platform or Base-Mounted Components.* *PATRIOT* platform or base-mounted components may be transported on a number of commercial or military semitrailers of adequate length and weight capacity, such as the M269A1 or M270A1-series semitrailers. Typical semitrailer loading of the *PATRIOT* platform or base-mounted

AMG and EPP is shown in figure 5-11. Bill and application of materials for blocking and tiedown are shown in tables 5-13 and 5-14, respectively. Platform or base-mounted components are lifted to their tiedown position as described in paragraph 6-4b(4).

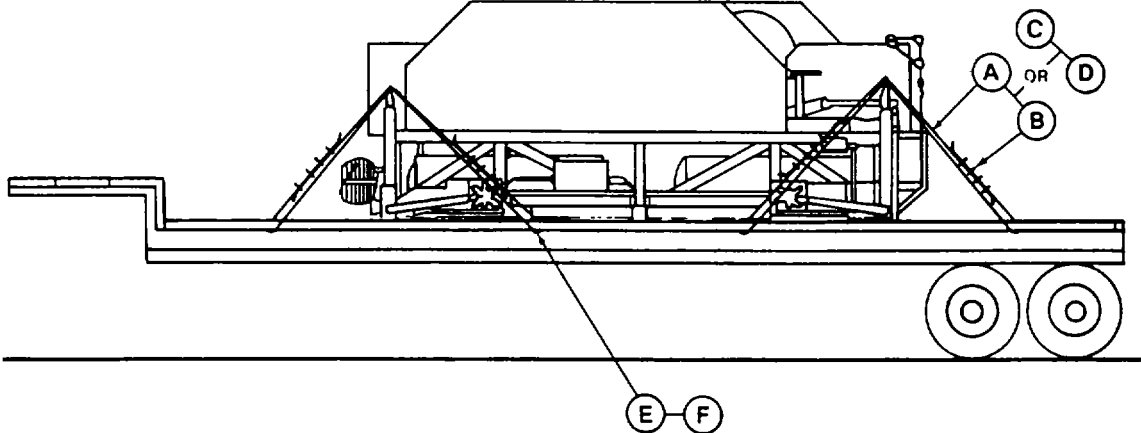
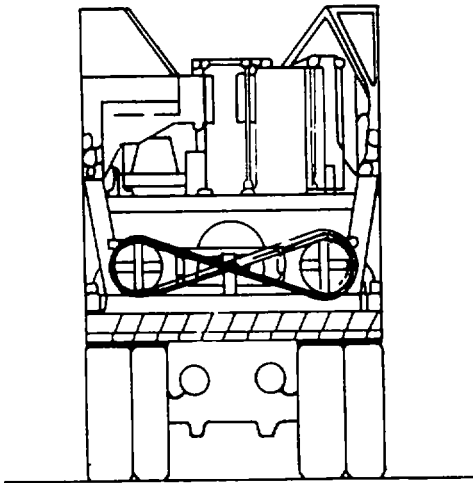

Figure 5-11. Blocking and tiedown of the PARIOT platform- or base-mounted components on an M269A1 of M270A1 semitrailer.

Table 5-11. Bill of Materials for Blocking and Tiedown of the PATRIOT RS on Semitrailers (Fig 5-10)

Item	Description	Approximate Quantity
Lumber	Douglas-fir, or comparable, straight-grain, free from material defects; Fed Spec MM-L-751C: 2- x 4-inch	34 linear feet
	2- x 6-inch	9 linear feet
	2- x 10-inch	288 linear feet
Nails	Common, steel; flathead; bright or cement-coated; table X1-b, Fed Spec FF-N-105A: 12d	189
	20	229
Shackle....	Anchor, screw pin, 1-inch pin size; NSN 4030-00-542-3182, or equal.	2
Chain	General service, S-leg, alloy steel, 1/4- to 1/2-inch size, 10-foot length, with two grabhooks.	16
Load binder.	Lever-operated, 4-inch takeup, with two grabhooks designed for 1/4- to 1/2-inch chain, 181/2-inch lever, large, 4-ton capacity, OD finish; MIL-B-1816 (NSN 3990-00-274-6746).	16

Table 5-12. Application of Materials for Blocking and Tiedown of the PATRIOT RS on Semitrailers (Fig 5-10)-Continued

Item	No. Required	Application
G	1	Lumber, 2- x 6- x 104-inch. Position even with edge of six bottom layers and nail with twelve 20d nails.
H	2	Lumber, 2- x 4- x 47 1/2-inch. Position as shown in figure 5-10, 43 1/2 inches apart, equally spaced off centerline of item G. Nail with six 20d nails.
I	1	Lumber, 2- x 4- x 43 1/2-inch. Position between items H with inside edge 23 inches from inside edge of item G. Nail with five 20d nails.
J	2	Lumber, 2- x 4- x 25 1/2-inch. Place in line with item I and 1 1/2 inches from outside edge of item H. Ensure 1 1/2-inch space is maintained. Nail with four 20d nails.
K	1	1st Layer Lumber, 2- x 10- x 39-inch. Position across semitrailer floor, 100 inches from item A, centered equally from each side, and nail with five 12d nails.
L	2	Lumber, 2- x 10- x 51 -inch. Place against ends of item K and nail with six 12d nails.
M	2	Lumber, 2- x 10- x 23-inch. Place against item L in line with item K and nail with four 12d nails.
N	1	2d Layer Lumber, 20- x 10- x 104-inch. Align on top of items K, L, and M and nail with ten 20d nails.
O	2	Lumber, 2- x 10-x 42-inch. Place against item N and nail to item L with six 20d nails. Repeat K through O for a total of six layers
P	1	Lumber, 2- x 4- x 50-inch. Place in center of item N, 3 inches from each edge and nail with six 20d nails.
Q	2	Lumber, 2- x 4- x 39-inch. Place in center of item O, flush with end of item P and nail with five 20d nails.
R	2	Lumber, 2- x 4- x 25 1/2-inch. Place in line with item P, 1 1/2 inches from end of item P. Ensure 1 1/2 inch space is maintained. Nail with four 20d nails. Place RS on support assembly

Table 5-12. Application of Materials for Blocking and Tiedown of the PATRIOT RS on Semitrailers (Fig 5-10)

Item	No. Required	Application
A	2	1st Layer Lumber, 2- x 10- x 39-inch. Position across semitrailer floor, centered equally from each side, and nail with five 12d nails. Position second piece parallel to the first piece, 16 inches apart, and nail the same as the first piece.
B	2	Lumber, 2- x 10- x 49 1/2-inch. Place against ends of items A and nail with six 12d nails.
C	4	Lumber, 2- x 10- x 23-inch. Place against item B in line with item A and nail with four 12d nails.
D	2	2d Layer Lumber, 2- x 10- x 104-inch. Align on top of items A, B, and C and nail with ten 20d nails.
E	2	Lumber, 2- x 10- x 16-inch. Place between items D and nail with three 20d nails to item B.
F	2	Lumber, 2- x 10- x 24-inch. Place on item B against item D and nail with four 20d nails. Repeat A through F for a total of six layers

Table 5-12. Application of Materials for Blocking and Tiedown of the PATRIOT RS on Semitrailers (Fig 5-10)-Continued

Item	No. Required	Application
S	4	Chain, general service, S-leg, alloy steel, 1/4- to 1/2-inch size, 10-foot length, with two grabhooks. Pass one end of chain through tiedown shackle at upper side of RS and engage grabhooks on a convenient chain link. Pass other end of chain through stake pockets on the opposite side of the semitrailer. Tension each chain with a load binder, lever-operated, 4-inch takeup, with two grabhooks designed for 1/4- or 1/2-inch chain. Engage one grabhook into link of chain coming from tiedown fittings on RS. Pull chain through stake pocket and engage other grabhook into a convenient link. Pull lever down and lock into secured position.
T	4	Attach chain to lower tiedown fitting shackle and repeat application of item S.
U	4	Chain, general service, S-leg, alloy steel, 1/4- to 1/2-inch size, 10-foot length, with two grabhooks. Pass one end of chain through tiedown shackle at lower side of RS and engage grabhooks on a convenient chain link. Pass other end of chains through stake pockets on the same side of the semitrailer. Tension each chain with a load binder, lever-operated, 4-inch takeup, with two grabhooks designed for 1/4- to 1/2-inch chain. Engage one grabhook into link of chain coming from tiedown fitting on RS. Pull chain through stake pocket and engage other grabhook into a convenient link. Pull lever down and lock into secured position.
V	4	Attach chain to lower tiedown fitting shackle and repeat application of item U.
W	2	Shackle, anchor, screw pin. Install in upper rear tiedown fitting.

Table 5-13. Bill of Materials for Blocking and Tiedown of the PATRIOT Platform- or Base-Mounted AMG and EPP on M269A1 or M270A1 Semitrailers (Fig 5-11)

Item	Description	Approximate Quantity
Chain	General service, S-leg, alloy steel, 1/4- to 1/2-inch size, 10-foot length with two grabhooks.	8

Table 5-13. Bill of Materials for Blocking and Tiedown of the PATRIOT Platform- or Base-Mounted AMG and EPP on M269A 1 or M270A1 Semitrailers (Fig 5-11--Continued)

Item	Description	Approximate Quantity
Load binder.	Lever-operated, 4-inch takeup, With two grabhooks designed for 1/4- to 1/2-inch chain, 18 1/2-inch lever, large, 4-ton capacity, OD finish; MIL-B-1816 (NSN 3990-00-274-6746).	8
Wire rope	6 x 19, IWRC; improved plow steel; performed, regular-lay, table X, Fed Spec RR-W-410C: 3/8-inch.	160 feet
Thimbles..	Standard, open-type, 3/8-inch	8
Clamps ...	Wire rope, U-bolt clips, saddied, single-grip, steel, Crosby, heavy-duty or equal; Fed Spec FF-C-450d:	32
	3/8-inch	32
	1/2-inch	8

Table 5-14. Application of Materials for Blocking and Tiedown of the PATRIOT Platform- or Base-Mounted AMG and PP on M269A1 or M270A1 Semitrailers (Fig 5-11)

Item	No. Required	Application
A	8	Chain, general service, S-leg, alloy steel, 1/4- to 1/2-inch size, 10-foot length, with two grabhooks. Attach two chains to each tiedown fitting. (If the tiedown fitting is not large enough to receive two chains, install suitable shackles in tiedown points that will receive two chains.) Attach one chain each to forward and aft stake pockets. Select stake pockets that will provide a maximum chain-to-floor angle of 45 ~ without contacting antenna mast structure. Engage grabhooks on a convenient chain link. Repeat for other three tiedown points.
B	8	Load binder, lever-operated, 4-inch takeup, with two grabhooks designed for 1/4- to 1/2-inch chain. Engage hook on chain link coming from the tiedown fitting. Engage opposite hook on chain link coming from the stake pocket. Do not overtension chains; adjust grabhooks to next link to achieve proper tension. Pull lever down and lock into secured position.
*C	8	Wire rope, 3/8-inch. Form a complete loop between tiedown fitting and the thimble (item E) in the appropriate stake pocket as described in item A. Ends of wire rope should overlap about 24 inches (item D, detail 3, fig 5-4).

Table 5-14. Application of Materials for Blocking and Tiedown of the PATRIOT Platform- or Base-Mounted AMG and EPP on M269A1 or M270A1 Semitrailers (Fig 5-11)Continued

Item	No. Required	Application
*D	32	Clamps, 3/8-inch. Place four clamps on each item C at the overlap area. Space clamps 4 inches apart (item E, detail 3, fig 5-4).

Table 5-14. Application of Materials for Blocking and Tiedown of the PATRIOT Platform- or Base-Mounted AMG and EPP on M269A1 or M270A1 Semitrailers (Fig 5-11)-Continued

Item	No. Required	Application
*E	8	Thimbles, 3/8-inch. Place on thimble between wire rope and bottom edge of stake pocket (item F, detail 3, fig 5-4).
*F	8	Clamps, 1/2-inch. Place one clamp on each item E (item G, detail 3, fig 5-4).

*Wire rope may be substituted for chains and binders.

CHAPTER 6

MARINE AND TERMINAL TRANSPORTABILITY GUIDANCE

Section I. GENERAL

6-1. Scope

This chapter provides marine and terminal transportability guidance for movement of the PATRIOT missile system. It covers technical and physical characteristics of and safety considerations for the PATRIOT system components. It also prescribes the materials and guidance required to prepare, load, tie down, and unload the system components.

6-2. Safety

Besides those safety precautions in chapter 3, the following applies:

a. The activity offering the cargo for transport must notify the carrier if ammunition and/or explosives are to be transported with the vehicles, in compliance with paragraph 2-7, AR 55-228.

b. Ammunition, explosives, and vehicles will be handled and stowed in accordance with provisions contained in Title 46/49, Code of Federal Regulations.

c. Fire extinguishers must be available during loading and unloading operations.

d. The fuel tanks on vehicles and self-powered items must not be more than one-fourth full.

e. All slings, lifting rings, shackles, and other items used in loading and discharging operations should be inspected for their condition and adequate capacity.

f. All personnel should be cautioned not to stand or walk under vehicles being lifted.

g. All lifts should have at least two tag lines attached to control the swing of the items while suspended.

6-3. Water Shipment

Marine transport of the PATRIOT system components can be accomplished without significant restrictions because of vehicle dimensions or weight. Hold-by-hold analysis for hatch length, stowage, and height and boom capacity is required for cargo ships, with most ships having holds capable of stowing the PATRIOT system components. The PATRIOT system components are transportable by a variety of inland waterway cargo carriers and lighters, seagoing cargo vessels, barge-ship systems, roll-on/roll-off (RORO) vessels, and logistics-over-the-shore (LOTS) craft of adequate size and capacity.

NOTE

The methods described in this chapter are recommended procedures for lifting and securing the PATRIOT system components. Other methods of handling and stowing may be used provided they will ensure safe delivery without damage.

Section II. LOADING AND SECURING

6-4. General Rules for Stowing

a. *General.* When possible, the PATRIOT system components should receive the protection of below deck stowage. In general, good stowage of vehicles means placing vehicles fore and aft as close together as practicable with minimum spacing between vehicles, and between outer vehicles and sweatboards. Protect breakable parts and secure spare parts in or near the vehicles. Stow vehicles in neutral, set brakes, disconnect battery terminals, and secure with adequate blocking and lashing. Securing includes blocking wheels on all four sides to restrict movement in any direction; bracing individual vehicle blocks to bulkheads, stanchions, and other vehicle blocks; or lashing vehicle with wire rope or chain.

NOTE

Department of Transportation Exemption (DOT-E-7280) authorizes DOD to ship vehicles with fuel tanks three-quarters full when vessels are adequately ventilated by power blowers, such as the roll-on/roll-off (RORO) vessels.

b. *Lifting the PATRIOT System Components.*

CAUTION

Rig sling leg lengths so that components lift as near level as practicable.

(1) The forward lifting provisions for the M977, M983, and M985E1 are the same on all vehicles, but the rear lifting provisions are different on each model. The M977 lift points are at the base of the crane and require removal of the cargo bed rear end panel.

Figure 6-1 shows the lifting procedures for the M977. The M983 lift points are at the rear ends of the frame. The M985E1 does not have permanent rear lifting provisions.

A lifting device, shown in figure 6-2, is the only acceptable method for lifting the M985E1. Each model will require different sling leg lengths for level lifting.

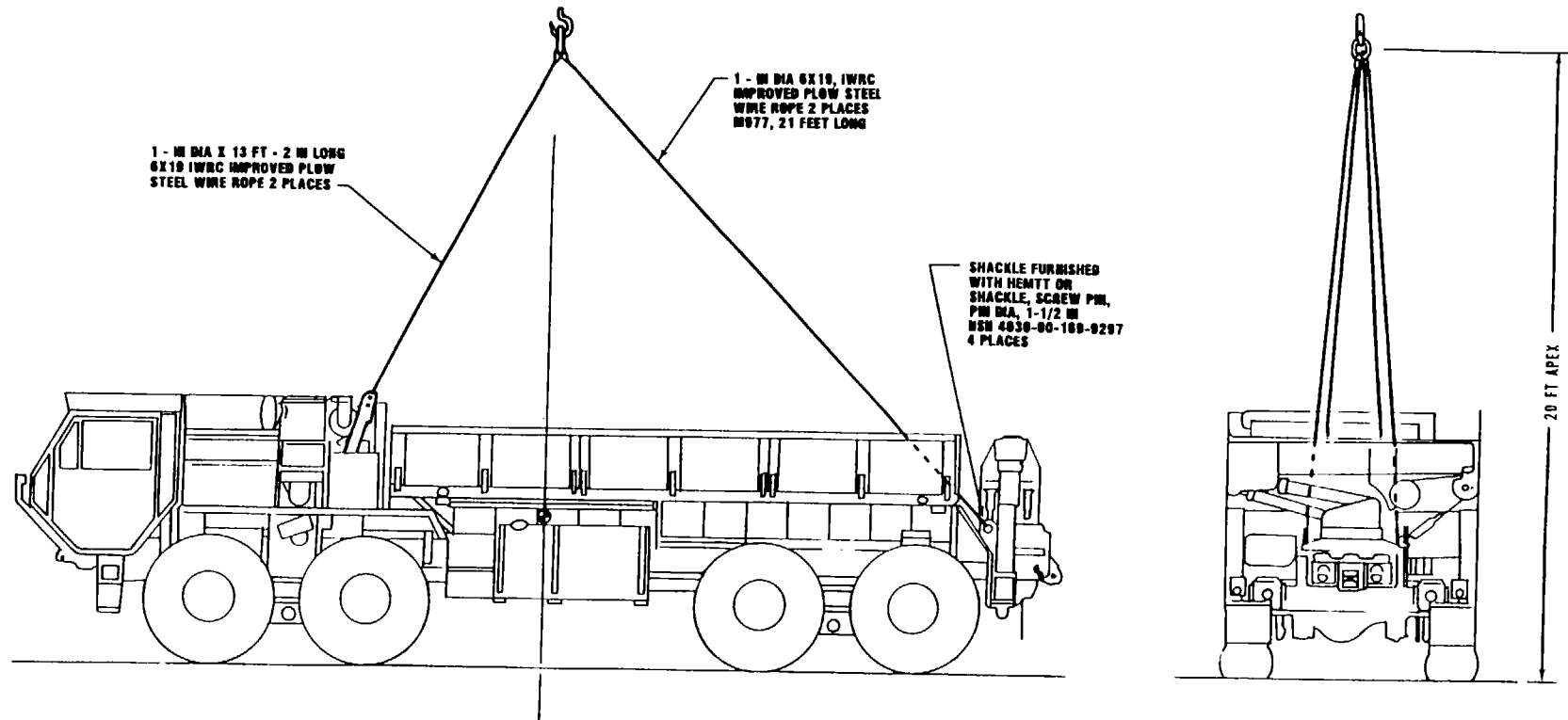
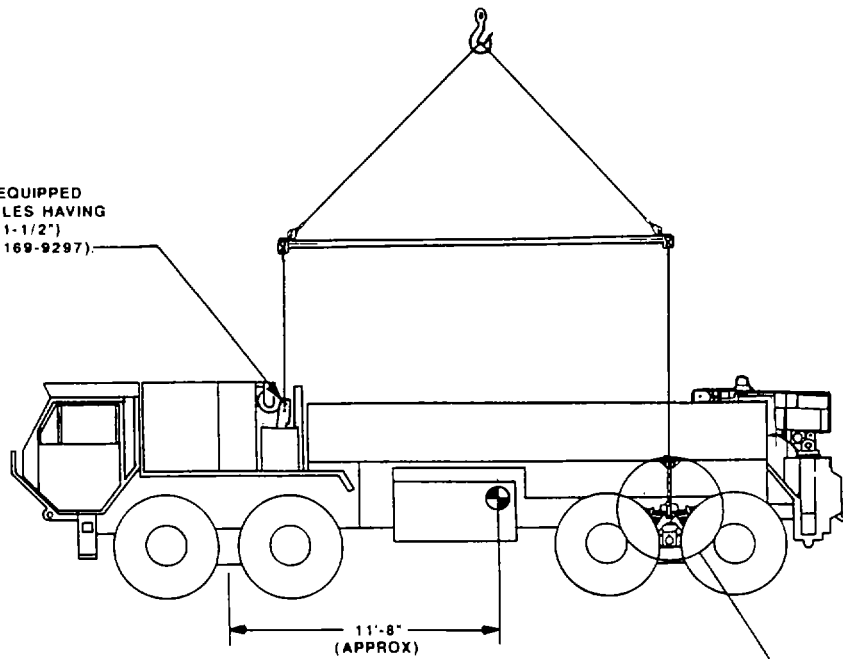

Figure 6-1. Typical lifting diagram for the M977.

IF LIFTING POINTS ARE NOT EQUIPPED WITH SHACKLES, USE SHACKLES HAVING A ONE AND ONE-HALF INCH (1-1/2") PIN DIAMETER (NSN 4030-00-169-9297).



ELEVATION VIEW

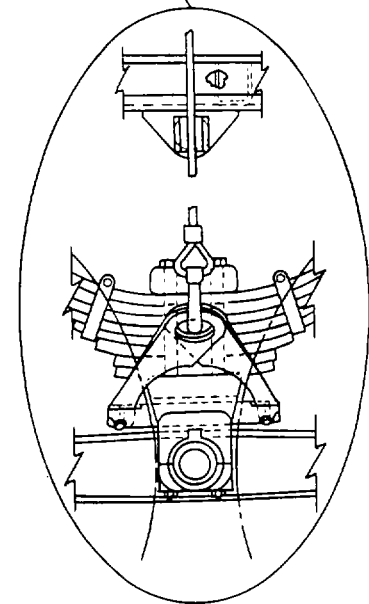

Figure 6-2. Lifting diagram for the M985E1, rear

(2) The forward lifting provision on the M927, M928, M942, M931, and M932 5-ton trucks are not to be used when a load is placed on the vehicles. Use wire rope sling leg extensions and thread over the frame and under the front bumper, as shown in figures 6-3 and 6-4. When the 5-ton trucks do not have a winch, use a

longitudinal spreader bar to prevent damage to their front. Lateral spreader bars are required for rear sling legs when lifting shelter-mounted components to prevent contact of the sling legs with items mounted on the shelter sides.

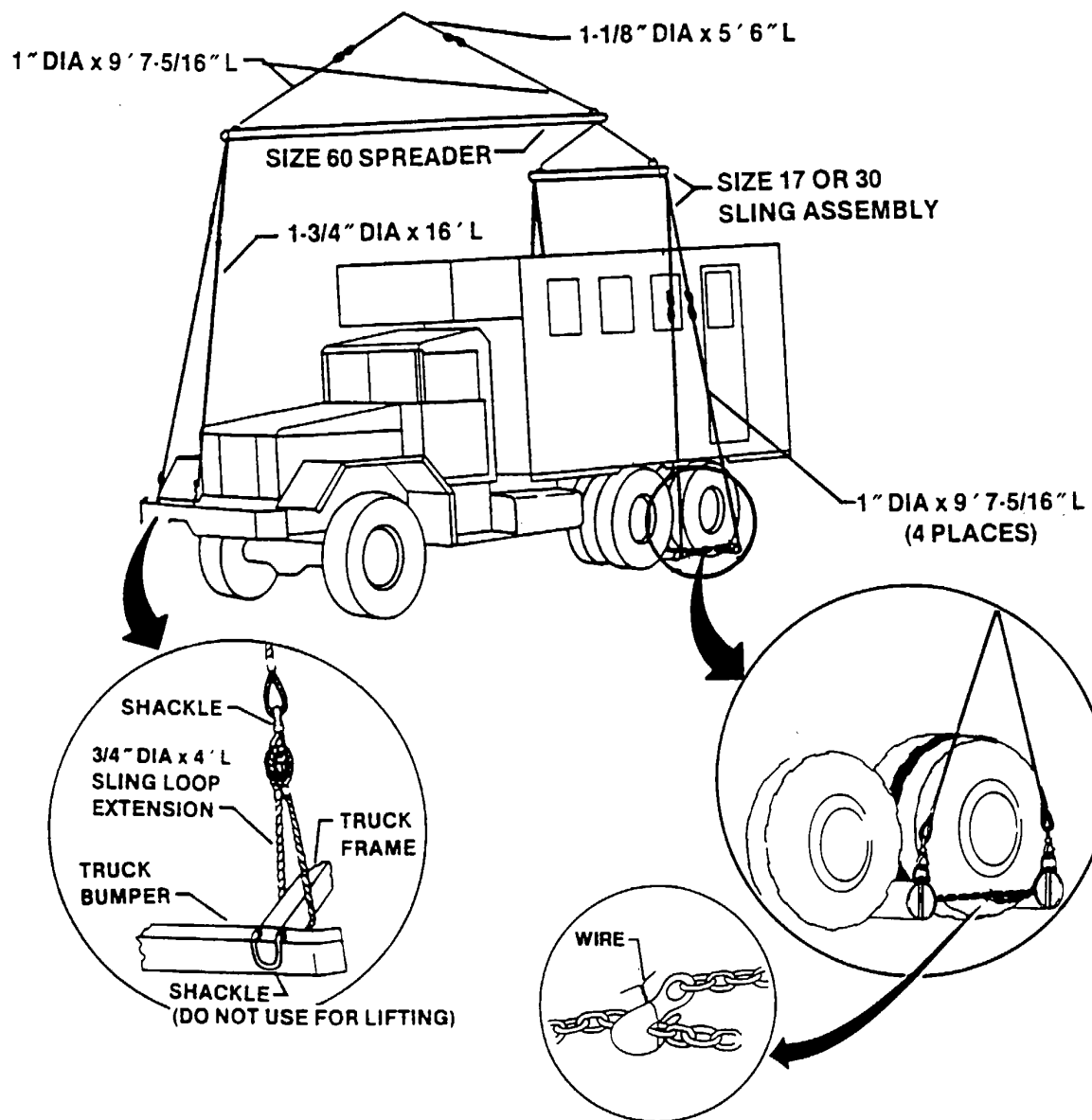

Figure 6-3. Typical lifting diagram for the M927, M928, and M942.

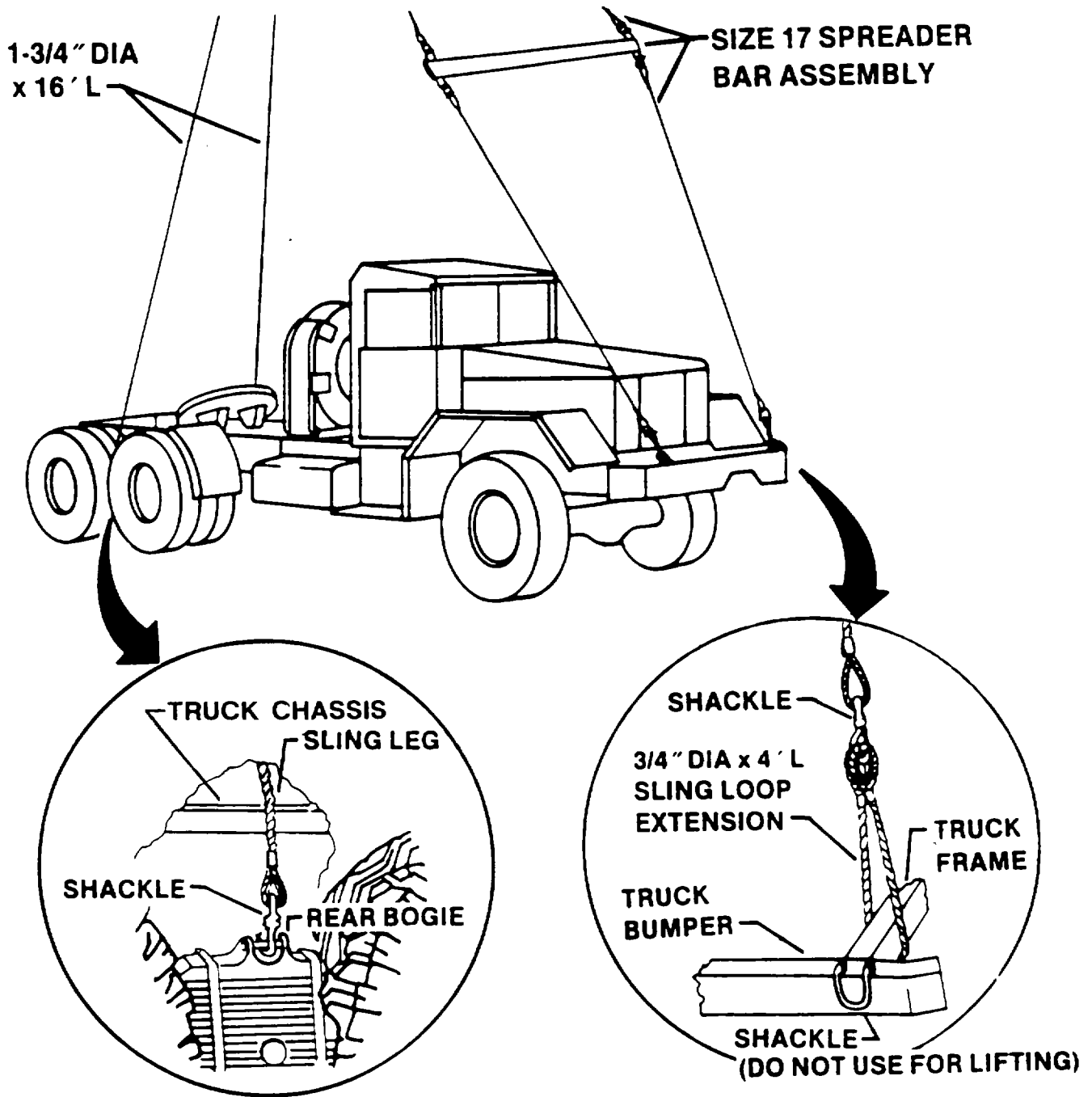

Figure 6-4. Typical lifting diagram for the M942 chassis, M931, and M932.

(3) The M860A1 semitrailer with the launcher station (LS) can be lifted with a four-leg, single apex sling, as shown in figure 6-5. The radar set (RS) must be removed from the M860A1 semitrailer to allow single-apex lift of the semitrailer. Components removed from the M860A1 semitrailer can also be lifted with a single-apex sling; however, a lateral spreader bar between the forward

sling legs is required for lifting for lifting the RS to prevent contact with the phased array antenna shown in figure 6-6. This lift method also applies to other shelter-mounted systems. When lifting the radar set mounted on the M860A1 semitrailer, a longitudinal spreader bar is required to prevent contact with the phased array antenna shown in figure 6-7.

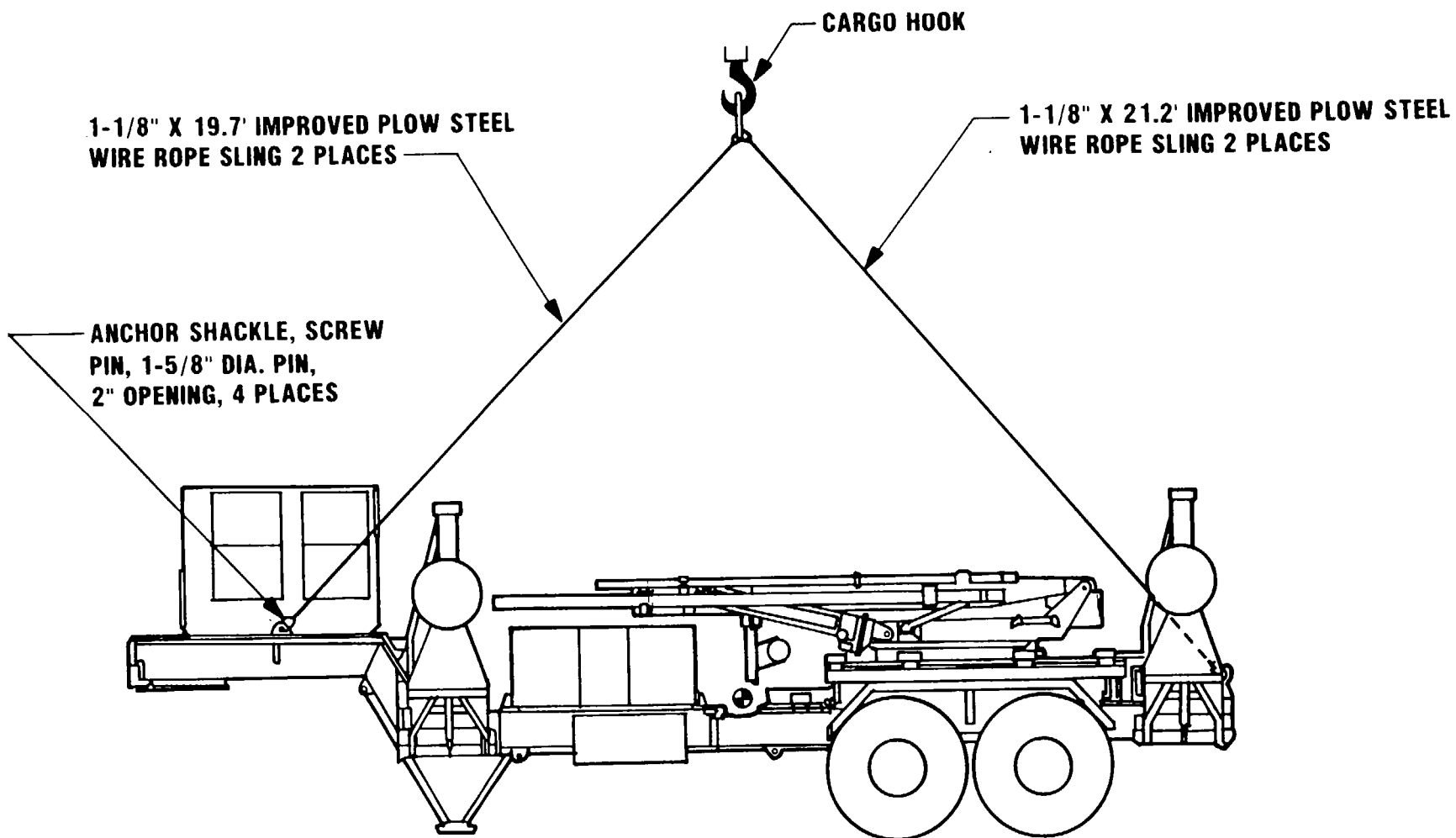
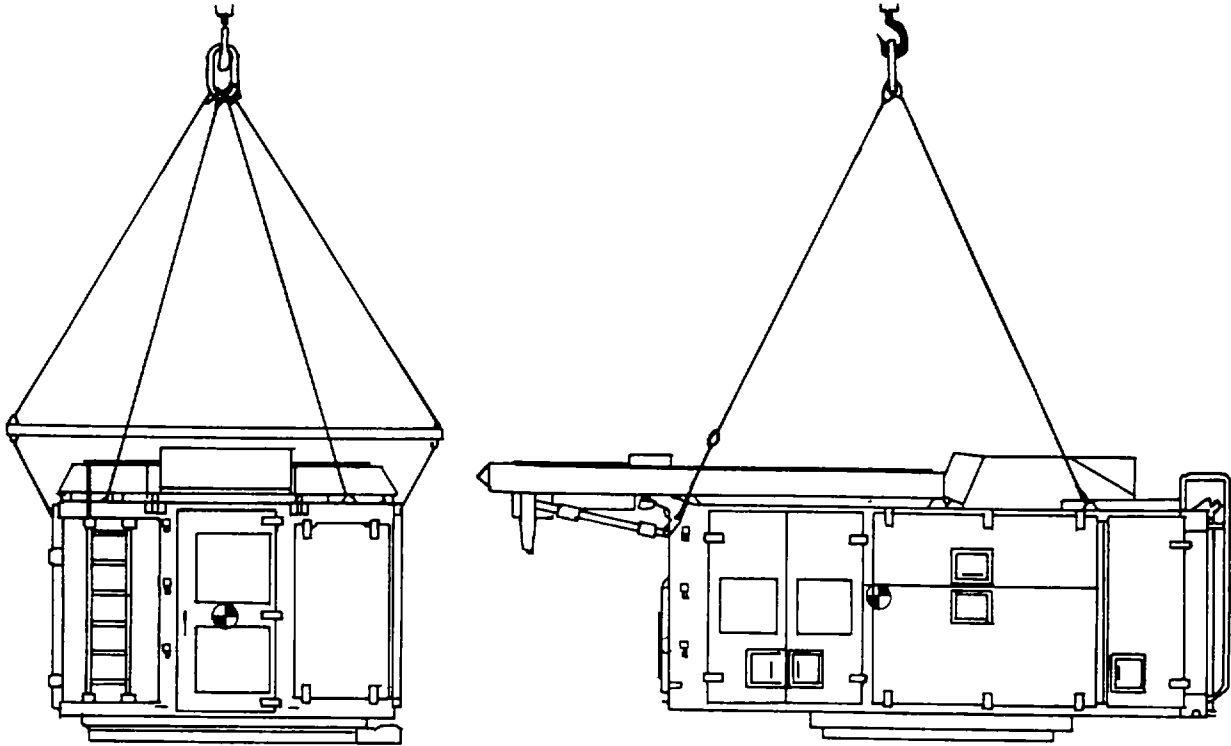
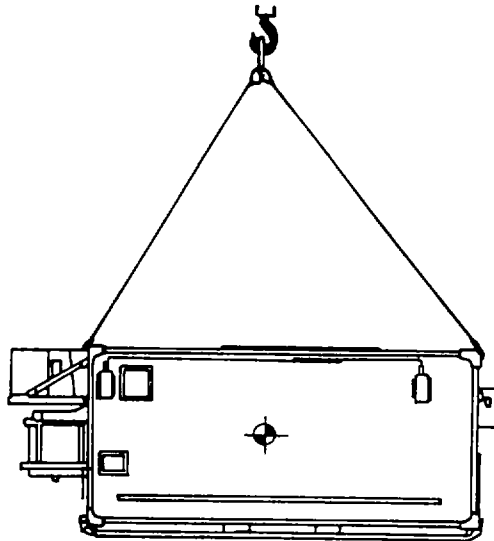

Figure 6-5. Lifting diagram for the M860A1 semitrailer using a four-leg sling.



RS



SHELTER

Figure 6-6. Lifting diagram for the RS and the shelter-mounted control centers (ICC, ECS, and CRG).

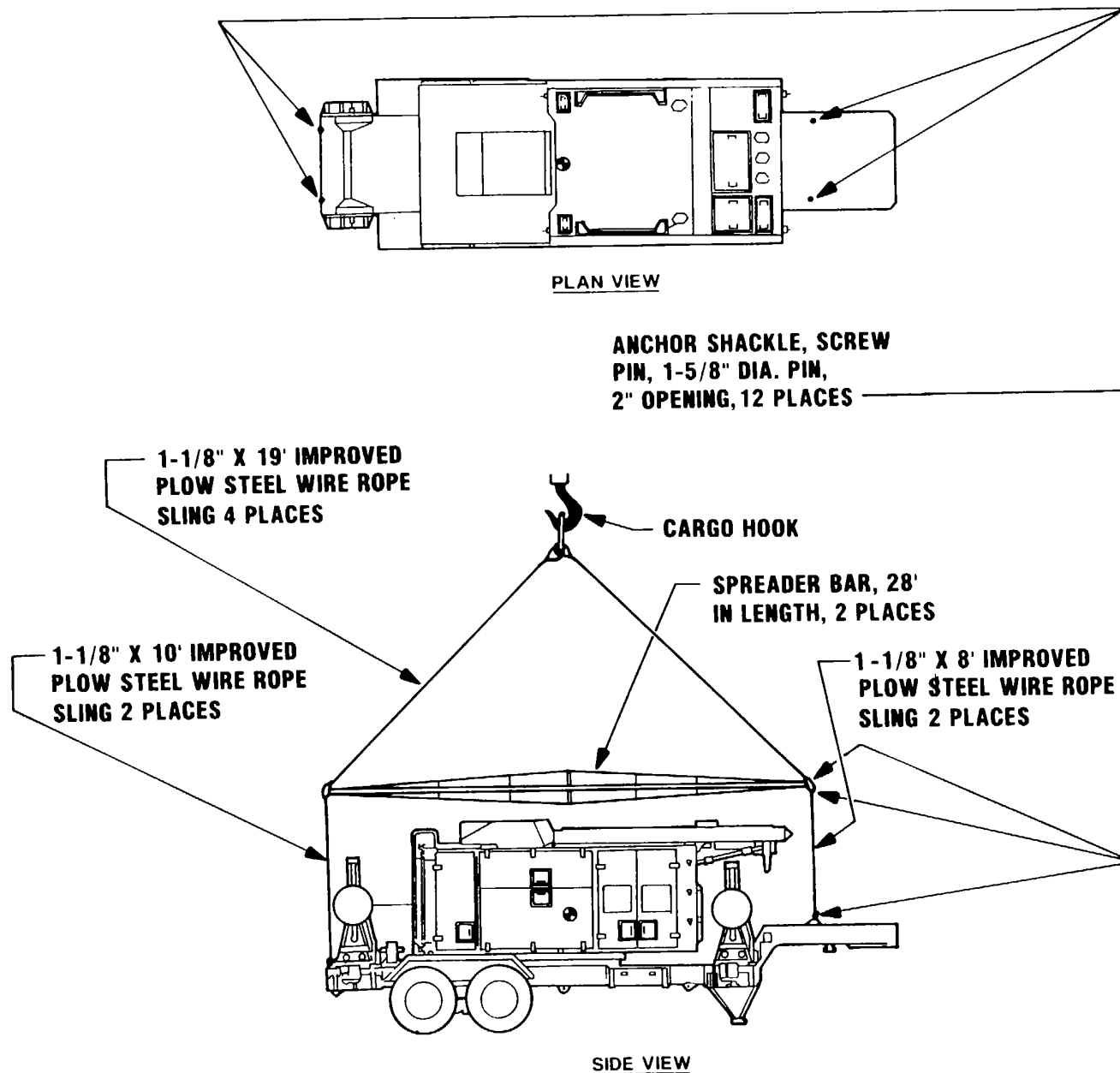

Figure 6-7. Lifting diagram for the RS mounted on an M860A1 semitrailer using eight wire rope sling legs and two spreader bars.

(4) The trailer-mounted components, such as the EPU II, can be lifted with a single-apex, four leg sling. However, if the apex is not high enough

to prevent sling leg contact with the generator, a lateral spreader bar will be required as shown in figure 6-8.

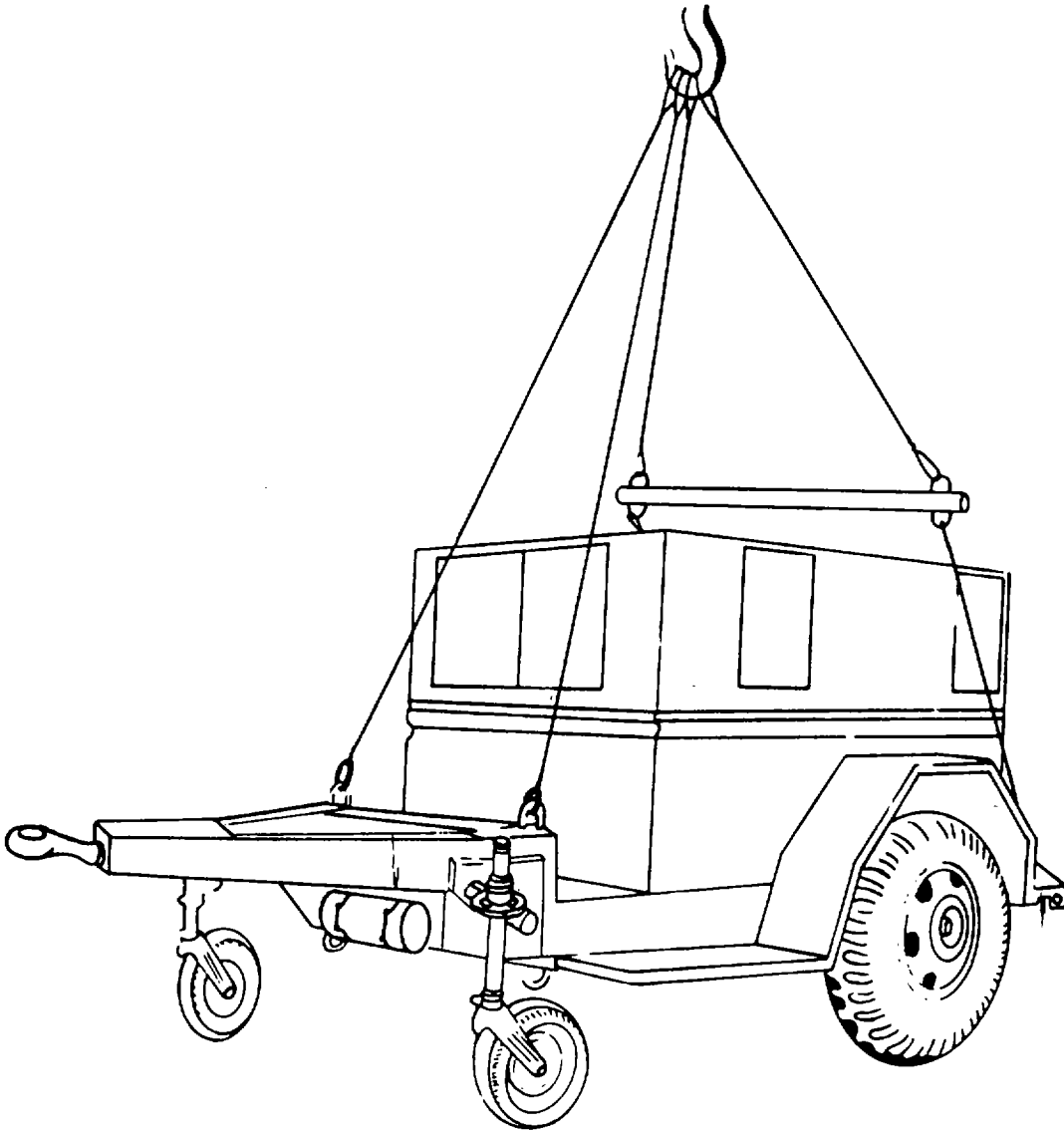

Figure 6-8. Lifting diagram for EPU II using a six-wire sling and one spreader bar.

c. Loading. Vehicles are always loaded onto vessels in their minimum configuration; that is, reduced width and length, with or without cargo. Height reduction is according to clearances available on the vessels. Vehicles with cargo or shelters higher than the cab, the cab height would not be reduced. The PATRIOT components can be lifted by crane of adequate capacity or driven or towed into landing craft and beach discharge and amphibious lighters. They can also be driven or towed into the decks of barges from a pier when tidal conditions are suitable and ramps are available.

The components can be lifted by shoreside or floating cranes of adequate capacity onto seagoing vessels. Jumbo booms and heavy lift ship's gear may be used in loading components onto vessels. The components can be driven or towed onto roll-on/roll-off vessels.

d. Tiedown. Typical blocking and tiedown details for the PATRIOT components on general cargo vessels are shown in figures 6-9 through 6-13. The bill and application of materials are contained in tables 6-1 through 6-10.

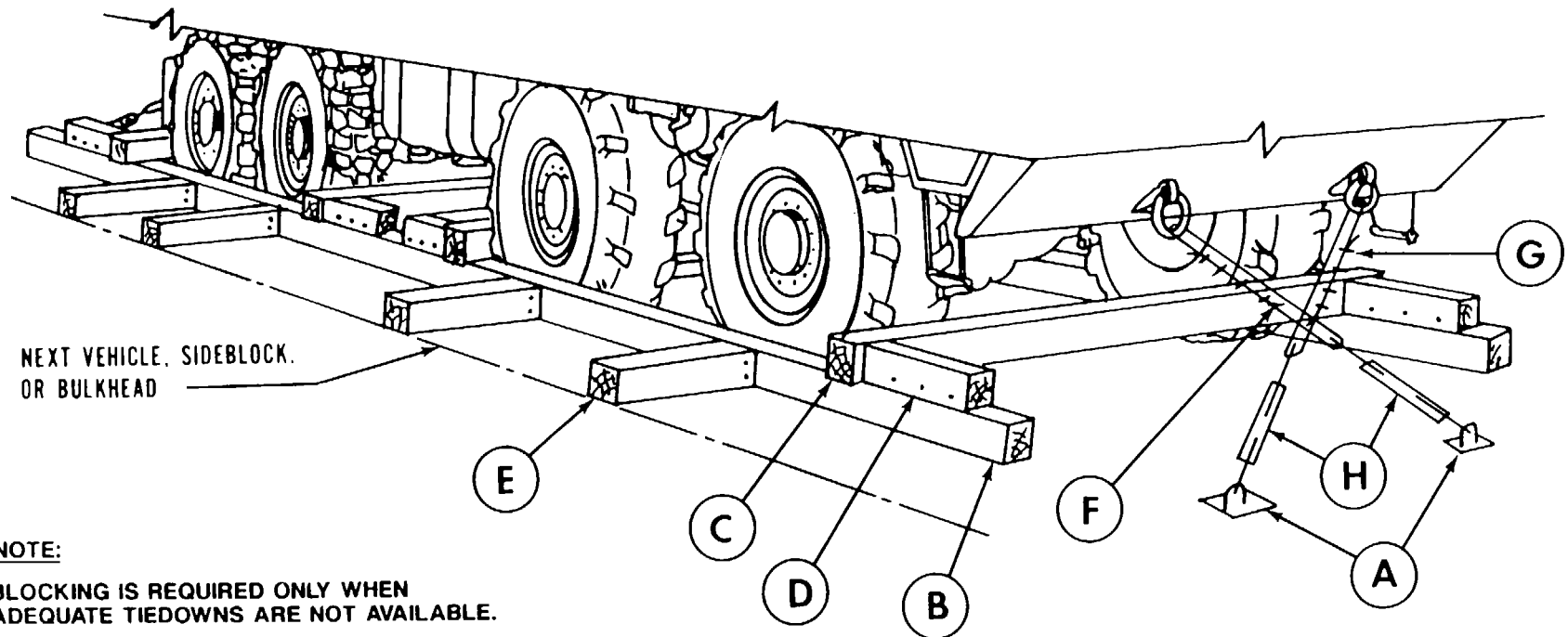
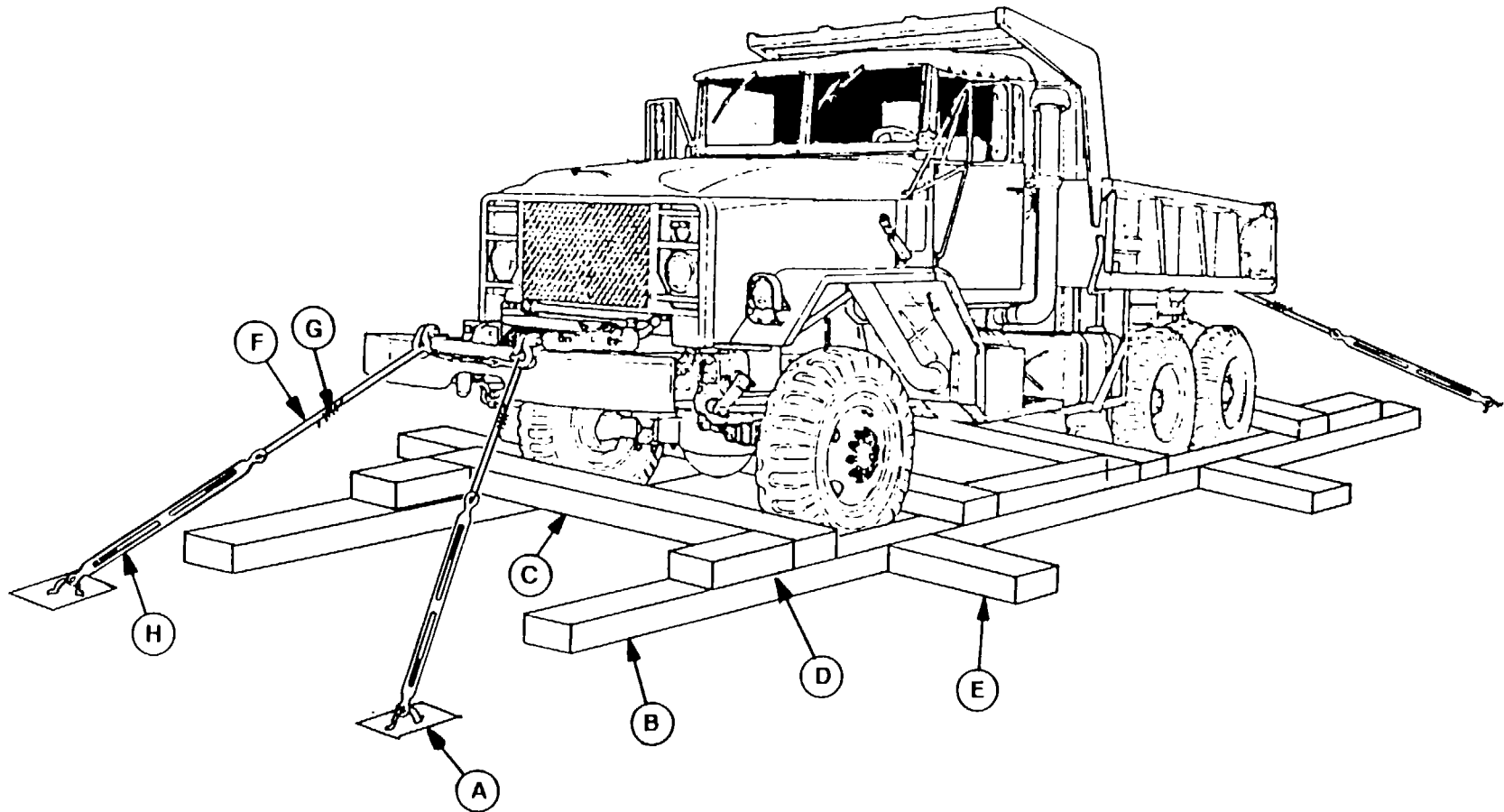

Figure 6-9. Blocking and tiedown of the M985E1, M983, and M977 vehicles in a general cargo vessel.



NOTE:

**BLOCKING IS REQUIRED ONLY WHEN
ADEQUATE TIEDOWNS ARE NOT AVAILABLE.**

Figure 6-10. Blocking and tiedown of the M927, M928, M942, M931, and M932 vehicles in a general cargo vessel.

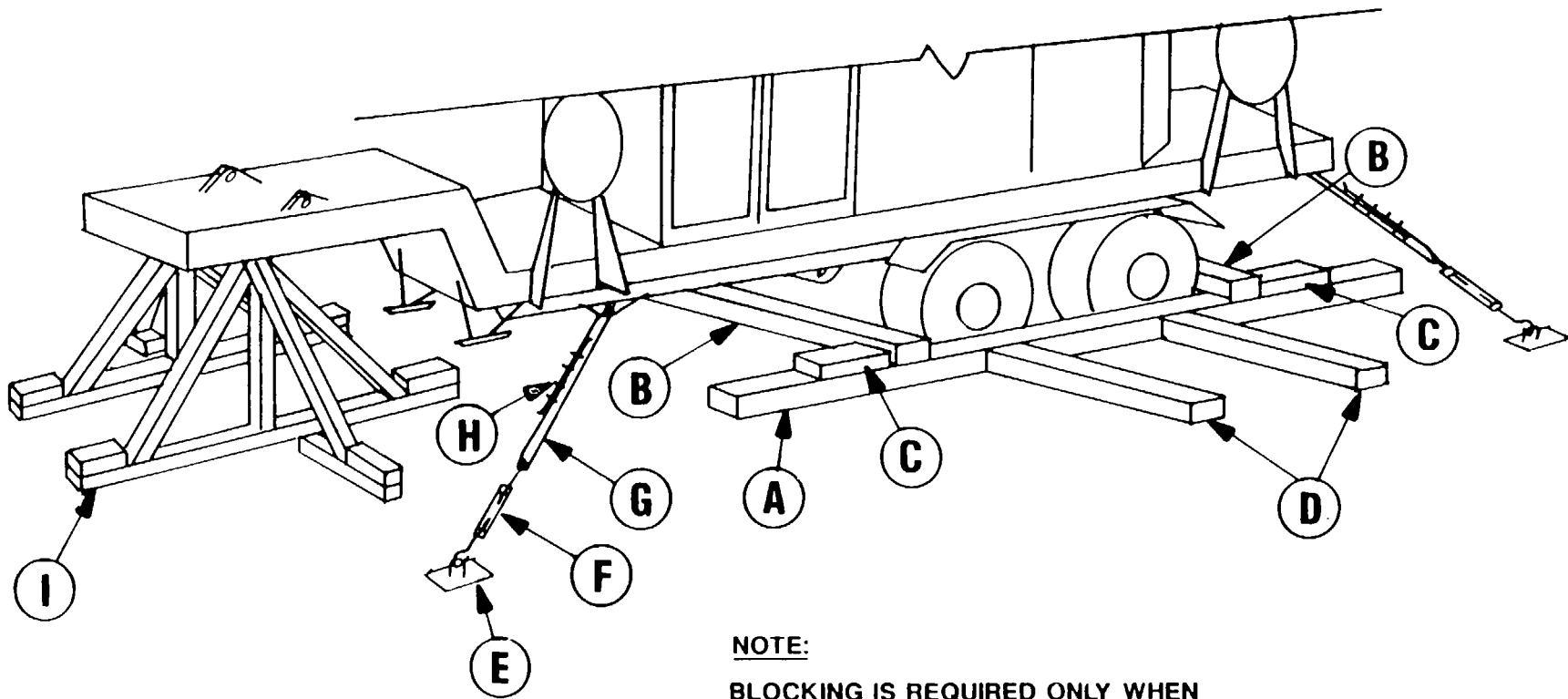

NOTE:

**BLOCKING IS REQUIRED ONLY WHEN
ADEQUATE TIEDOWNS ARE NOT AVAILABLE.**

Figure 6-11. Typical blocking and tiedown of the RS and LS mounted on an M860A1 semitrailer in a general cargo vessel.

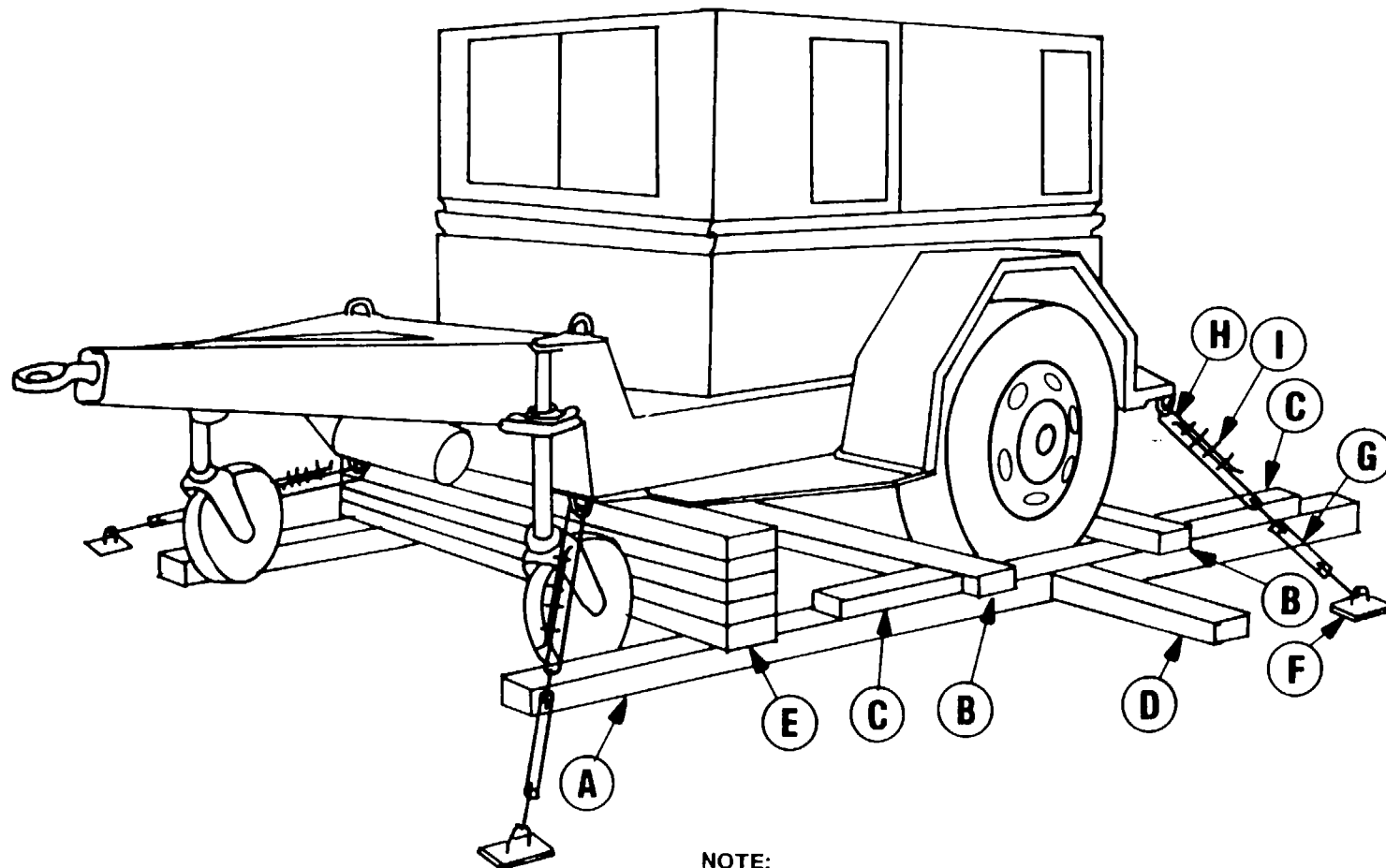

NOTE:

**BLOCKING IS REQUIRED ONLY WHEN
ADEQUATE TIEDOWNS ARE NOT AVAILABLE.**

Figure 6-12. Typical blocking and tiedown of the PATRIOT trailer-mounted components in a general cargo vessel.

Table 6-1. Bill of Materials for Blocking and Tiedown of the M985E1, M983, and M977 Vehicles in General Cargo Vessel (Fig 6-9)

Item	Description	Approximate Quantity
Lumber ...	Douglas-fir, or comparable; straight-grain, free from material defects; Fed Spec MM-L-751H: 6- x 8-inch.	116 linear feet
Nails	Common, steel, flathead; bright or cement-coated; table X1-b, Fed Spec FF-N-105: 40d.	100
Wire rope;	6 x 19, IWRC; improved plow steel; performed, regular-lay; Fed Spec RR-W-410C: 5/8-inch.	80 feet
Clamps ...	Wire rope, U-bolt clips, saddled, single-grip, steel, Crosby heavy-duty, or equal; Fed Spec FF-C-450D: 5/8-inch.	16
Shackles..	Anchor, screw pin; Type IV, Class I; Fed Spec RR-C-271B: 1 3/8-inch (1/2-inch pin diameter); NSN 4030-00-169-9297 (required if vehicle shackle is missing).	4
Turn-buckles.	1- x 18-inch with jaw and jaw-end fittings.	4
Padeyes...	Local manufacture, from 1-inch steel rod and 4- x 6- x 5/8-inch steel plate. Bore 1-inch holes through plate, and weld U-shaped 1-inch rod ends on top and bottom of plate.	4

Table 6-2. Application of Materials for Blocking and Tiedown of the M985E1, M983, and M977 Vehicles in General Cargo Vessel (Fig 6-9)-Continued

Item	No. Required	Application
E	as required	Bracing. Each consists of 6- x 8-inch x length-cut-to-fit lumber. Brace as required against adjacent vehicle cargo, side of vessel, or bulkhead, as appropriate. Materials for this requirement are not included in table 6-1.
F	4	Wire rope, 5/8-inch. Form a complete loop. Secure with clamps (item G). Attach to front and rear tiedown shackles.
G	16	Clamps, 5/8-inch. Install four clamps on each item F, with 4-inch spacing between clamps.
H	4	Turnbuckles, 1- x 18-inch. Attach one jaw to wire rope (item F) and one jaw to padeye (item A) or deck fitting. Tighten all turnbuckles evenly.

Table 6-3. Bill of Materials for Blocking and Tiedown of a Typical 5-Ton, 6 x 6 M800 or M939-Series Truck in the Hold of a General Cargo Vessel (Fig 6-10)

Item	Description	Approximate Quantity
Lumber ...	Douglas-fir, or comparable, straight-grain, free from material defects; Fed Spec MM-L-751: 6- x 8-inch.	150 linear feet
Nails	Common, steel; flathead; bright or cement-coated; table X1-b, Fed Spec FF-N-105: 40d.	90
Wire rope.	6 x 19, IWRC; improved plow steel; performed; regular-lay; Fed Spec RR-W-410: 5/8-inch diameter.	50 feet
Clamps ...	Wire rope, U-bolt clips, saddled, single-grip, steel, Crosby heavy-duty, or equal; Fed Spec FF-C-450: 5/8-inch.	16
Turn-buckles.	1- x 18-inch with jaw and jaw-end fittings.	4
Padeyes...	Local manufacture, from 1-inch steel rod and 4- x 6- x 5/8-inch steel plate. Bore 1-inch holes through plate, and weld U-shaped 1-inch rod ends on top and bottom of plate.	4

Table 6-2. Application of Materials for Blocking and Tiedown of the M985E1, M98S, and M977 Vehicles in General Cargo Vessel (Fig 6-9)

Item	No. Required	Application
A	4	Padeyes. Weld padeyes to the vessel deck if D-rings or deck tiedown fittings are unavailable.
B	4	Side blocks. Each consists of one piece of 6- x 8- x 192-inch lumber. Place one piece centered against outside of each pair of wheels. Place the 8-inch side vertical, with the 6-inch side on the deck.
C	4	End blocks. Each consists of one piece of 6- x 8- 120-inch lumber. Place on top of item B and against wheels as shown in figure 6-9, with 6-inch side on item B. Toenail to item B with four 40d nails at each end of each item C.
D	8	Backup cleats. Each consists of 6- x 8- x 18-inch lumber. Place on top of item B against the joint of each item C. Nail to item B with six 40d nails each.

Table 6-4. Application of Materials for Blocking and Tiedown of a Typical 5-Ton, 6 x 6 M800- or M939-Series Truck in the Hold of a General Cargo Vessel (Fig 6-10)

Item	No. Required	Application
*A	4	Padeyes. Weld padeyes to the vessel deck if D-rings or deck tiedown fittings are unavailable.
*B	4	Side blocks. Each consists of one piece of 6- x 8- x 192-inch lumber. Place one piece centered against outside of each pair of wheels. Place the 8-inch side vertical, with the 6-inch side on the deck.
*C	4	End blocks. Each consists of one piece of 6- x 8- x 120-inch lumber. Place on top of item B and against wheels as shown in figure 6-10, with 6-inch side on item B. Toenail to item B with four 40d nails at each end of each item C.
*D	8	Backup cleats. Each consists of 6- x 8- x 18-inch lumber. Place on top of item B against the joint of each item C. Nail to item B with six 40d nails each.
*E	as required	Bracing. Each consists of 6- x 8-inch x length-cut-to-fit lumber. Brace as required against adjacent vehicle cargo, side of vessel, or bulkhead, as appropriate. Materials for this requirement are not included in table 6-3.
F	4	Wire rope, 5/8-inch. Form a complete loop. Secure with clamps (item G). Attach to front and rear tiedown shackle.
G	16	Clamps, 5/8-inch. Install four clamps on each item F, with 4 -inch spacing between clamps.
H	4	Turnbuckles, 1- x 18-inch. Attach one jaw to wire rope (item F) and one jaw to padeye (item A) or deck fitting. Tighten all turnbuckles evenly.

*Not required when the ship is equipped with adequate deck tiedown fittings.

Table 6-5. Bill of Materials for Blocking and Tiedown of the PATRIOT M860A1-Mounted Components in a General Cargo Vessel (Fig 6-11)

Item	Description	Approximate Quantity
Lumber	Douglas-fir, or comparable, straight-grain, free from material defects; Fed Spec MM-L-751H:	
	2- x 4-inch	27 linear feet
	2- x 6-inch	58 linear feet
	4- x 4-inch	38 linear feet
	4- x 6-inch	60 linear feet
Nails	Common, steel; flathead; bright or cement-coated; table X1-b, Fed Spec FF-N-105:	

Table 6-5. Bill of Materials for Blocking and Tiedown of the PATRIOT M860A1-Mounted Components in a General Cargo Vessel (Fig 6-11) Continued

Item	Description	Approximate Quantity
	12d	36
	16d	48
	20d	60
	30d	88
	60d	32
Wire rope.	Type I, general-purpose; Class 2, 6 x 19, improved plow steel, wire strand core or IWRC; Fed Spec RR-W-410C: 3/4-inch.	50 feet
Clamps ...	Wire rope, U-bolt clips, saddled, single-grip, forged steel, Crosby heavy-duty, or equal; Fed Spec FF-C-450D: 3/4-inch.	16
Turnbuckle.	1- x 24-inch	4
Padeye	Fabricate from 1-inch steel rod and 5/8- x 4- x 6-inch steel plate.	4

Table 6-6. Application of Materials for Blocking and Tiedown of the PATRIOT M860AI-Mounted Components in a General Cargo Vessel (Fig 6-11)

Item	No. Required	Application
*A	2	Side blocking for tandem-axle wheels, 4- x 6- x 132-inch lumber. Locate at side of rear wheels.
*B	2	Blocks, 4- x 6- x 132 inch lumber. Locate one in front and one in back of tandem-axle wheels. Toenail each end to side blocking, item A, with two 60d nails.
*C	4	Cleats, 4- x 6- x 24-inch lumber. Locate against item B and nail to item A with six 60d nails.
*D	as required	Bracing, 4- x 6-inch x random-length lumber, cut-to-fit. Place ends against side blocking, item A, to other cargo, side of vessel, or other ship's structure and toenail each end, where possible, with four 30d nails.
E	4	Padeye. If deck fittings are not available, make padeyes from 1-inch rod and 5/8- x 4- x 6-inch steel plate and weld to deck.
F	4	Turnbuckle, 1- x 24-inch, with jaw and jaw-end fittings. Open turnbuckle to at least 52-inch extension and attach one jaw to padeye.
G	4	Wire rope, 3/4-inch. Each wire rope will form a complete loop through the shackle on the vehicle tiedown fitting and the turnbuckle jaw fitting, item F.

**Table 6-6. Application of Materials for Blocking and Tiedown of the PATRIOT M860A1-Mounted Components in a General Cargo Vessel (Fig 6-11)
Continued**

Item	No. Required	Application
H	16	Clamps, 3/4-inch. Place four clamps over each cable loop where the ends of the wire rope overlap and space 4 1/2 inches apart with at least 6 inches from loose end of wire rope (see detail 3, fig 7-2).
I	1	Forward support blocking assembly. Construct similar to item E in Table 7-6 (fig 7-5). Item E should be preassembled and placed beneath the fifth wheel plate. Follow instructions in item K of Table 7-10 for item I placement and use. Note the caution statement at the end of Table 7-10 for item K.

*Not required when the ship is equipped with adequate deck tiedown fittings.

Table 6-7. Bill of Materials for Blocking and Tiedown of the PATRIOT Trailer-Mounted Components in a General Cargo Vessel (Fig 6-12)

Item	Description	Approximate Quantity
Lumber ...	Douglas-fir, or comparable, straight-grain, free from material defects; Fed Spec MM-L-751H:	
	2 x 6-inch	45 linear feet
	4- x 4-inch	48 linear feet
Nails	Common, steel; flathead; bright or cement-coated; table X1-b, Fed Spec FF-N-105:	
	16d	42
	50d	24
Wire rope.	Type I, general-purpose; Class 2, 6 x 19, improved plow steel, wire strand core or IWRC, Fed Spec RR-W-410C: 3/8-inch.	32 feet
Clamps ...	Wire rope, U-bolt clips, saddled, single-grip, forged steel, Crosby heavy-duty, or equal, Fed Spec FF-C-450D: 3/8-inch.	16
Turn-buckle.	1/2- x 12-inch.	4
Padeye.....	Fabricate from 1/2-inch steel rod and 3/8- x 3- x 5-inch steel plate.	4

Table 6-8. Application of Materials for Blocking and Tiedown of the PATRIOT Trailer-Mounted Components in a General Cargo Vessel (Fig 6-12)

Item	No. Required	Application
*A	2	Side blocking, 4- x4- x 120-inch lumber. Locate at side of trailer wheels.
* B	2	Blocks, 4- x 4- x 108-inch lumber. Locate one in front and one in back of wheels. Toenail each end to side blocking, item A, with two 50d nails.
* C	4	Cleats, 4- x 4- x 18-inch lumber. Locate against item B and nail to item A with four 50d nails.
* D	as required	Bracing, 4- x 4-inch x random-length lumber, cut-to-fit. Place ends against side blocking, item A, to other cargo.
E	1	Blocking, five pieces of 2- x 6- x 108-inch lumber. Locate the first piece across item A 3 inches aft of forward frame tiedown fitting and nail each end to item A with three 16d nails. Nail the next four pieces to the one below in same manner. Lower forward wheels until trailer frame rests on blocking, then retract wheels and apply tiedowns to items F, G, H, and I below.
F	4	Padeye. If deck fittings are not in the right place, make padeyes from 1/2-inch steel rod and 3/8- x 3- x 5-inch steel plate and weld to deck.
G	4	Turnbuckle, 1/2- x 12-inch with jaw and jaw-end fittings. Open turnbuckle at least 18-inch extension and attach one jaw to padeye.
H	4	Wire rope, 3/8-inch. Each wire rope will form a complete loop through the tiedown fitting and the turnbuckle jaw fitting, item G.
I	16	Clamps, 3/8-inch. Place four clamps over each cable loop where the ends of the wire rope overlap and space 2 1/4 inches apart, with at least 3 1/2 inches from loose ends of wire rope (see detail 3, fig 7-2).

*Not required when the ship is equipped with adequate deck tiedown fittings.

Table 6-9. Bill of Materials for Typical Blocking and Tiedown of a Two-Wheel Semitrailer in the Hold of a General Cargo Vessel (Fig 6-13)

Item	Description	Approximate Quantity
Lumber	Douglas-fir, or comparable, straight-grain, free from material defects; Fed Spec MM-L-751:	
	2- x 12-inch	6 linear feet
	2- x 4-inch	40 linear feet
	4- x 4-inch	20 linear feet

Table 6-9. Bill of Materials for Typical Blocking and Tiedown of a Two-Wheel Semitrailer in the Hold of a General Cargo Vessel (Fig 6-13tContinued

Item	Description	Approximate Quantity
Nails	4- x 6-inch Common, steel; flathead; bright or cement-coated; table X1- B, Fed Spec FF-N-105:	60 linear feet
	16d	30
	30d	50
	60d	12
Wire rope.	6 x 19, IWRC; improved plow steel; preformed, regular-lay; Fed Spec RR-W-410: 5/8-inch.	80 feet
Clamps ...	Wire rope, U-bolt clips, sad- died, single-grip, steel, Crosby heavy-duty, or equal; Fed Spec FF-C450: 5/8-inch.	24
Turn- buckles.	1- x 18-inch with jaw and jaw- end fitting.	6
Padeyes ..	Local manufacture, from 1- inch steel rod and 4- x 6- x 5/8-inch steel plate. Bore 1- inch holes through plate and weld U-shaped 1-inch rod ends on top and bottom of plate.	6

**Table 6-10. Application of Materials for Typical Blocking and Tiedown of a Two-Wheel Semitrailer in the Hold of a General Cargo Vessel (Fig 6-13)--
Continued**

Item	No. Required	Application
*B	1	Lumber, 2- x 12- x 72-inch. Place under landing legs.
*C	2	Side blocking, 4- x 6- x 96-inch. Place against wheels.
*D	2	Blocks, 4- x 6- x 108-inch. Place against the front and back of tires and nail to item C with two 60d nails.
*E	4	Cleats, 2- x 4- x 24-inch. Place on top of item C and firmly against item D and nail to item C with five 16d nails.
*F	as required	Bracing, 4- x 6-inch x cut-to-fit lumber. Place ends against side blocking of other cargo, side of ship, or other ship's structure. Nail to other wood bracing with four 30d nails.
G	1	Stanchion, 2- x 4-inch and 4- x 4-inch lumber. Construct stanchion as shown using 30d nails. Place under kingpin for additional support.
H	6	Wire rope, 5/8-inch. Form a complete loop between the tiedown point and turnbuckle. End should overlap about 24 inches.
I	24	Clamps, 5/8-inch. Place four clamps on each item H, spaced about 4 inches apart. Tighten clamps to 95 foot-pounds torque.
J	6	Turnbuckles, 1- x 18-inch. Attach one jaw to the wire item H and the other jaw to the padeye item A or deck fitting. Tighten all turnbuckles evenly.

*Not required when the ship is equipped with adequate deck tiedown fittings.

Table 6-10. Application of Materials for Typical Blocking and Tiedown of a Two-Wheel Semitrailer in the Hold of a General Cargo Vessel (Fig 6-13)

Item	No. Required	Application
A	6	Padeyes. Weld padeyes to the deck of vessel if D-rings or deck tiedown fittings are unavailable.

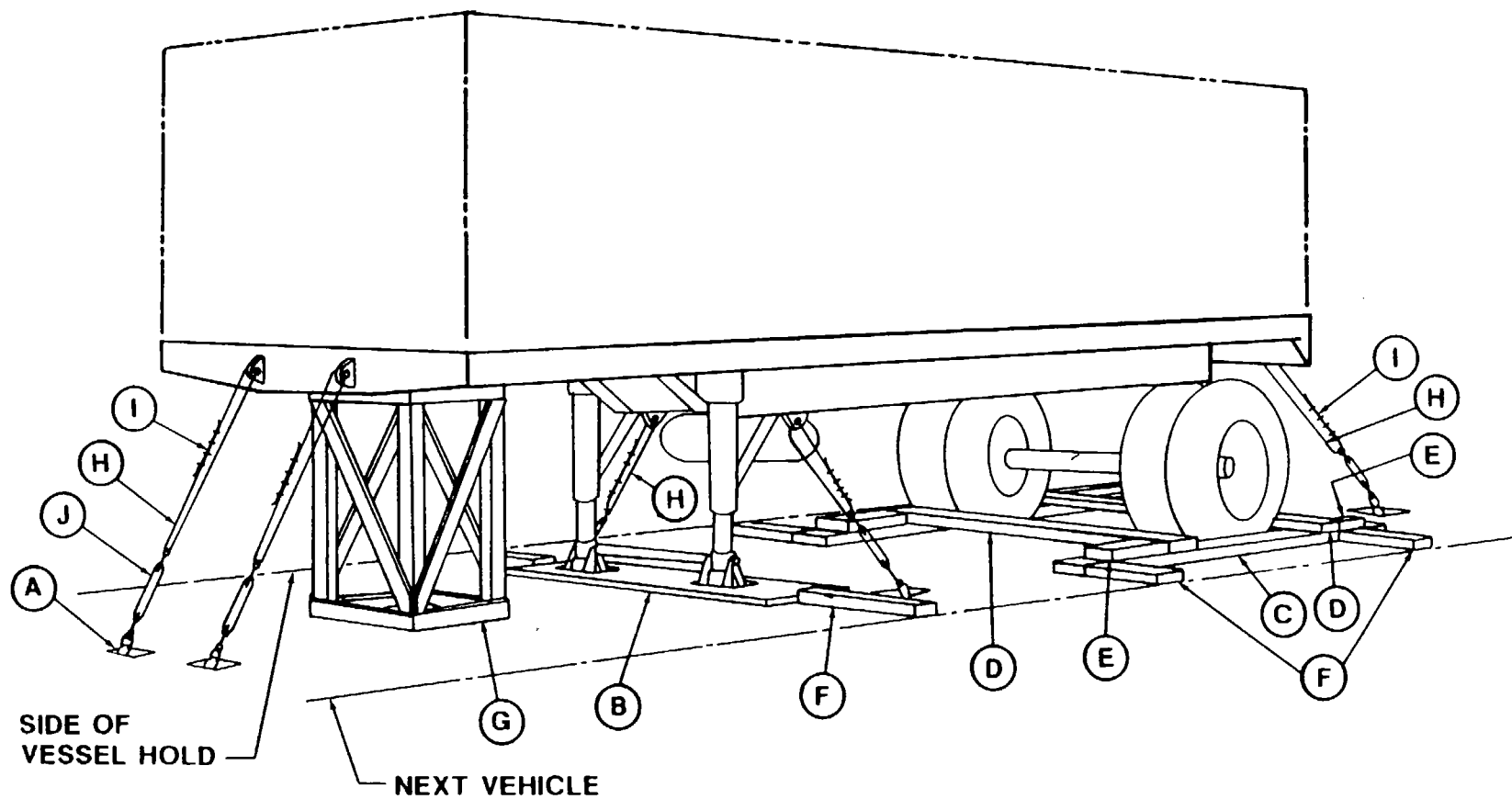

NOTE:

BLOCKING IS REQUIRED ONLY WHEN ADEQUATE TIEDOWNS ARE NOT AVAILABLE.

Figure 6-13. Typical blocking and tiedown of the PATRIOT semitrailer-mounted components in a general cargo vessel.

6-5. Special Design Ships

Roll-on/roll-off (RORO) vessels, landing ships, and attack-cargo vessels are all equipped with patented lashing gear and pre-positioned fittings in the deck. With proper application of lashing gear, blocking and bracing will not be required. Different

classes of RORO vessels have different grid patterns for pre-positioned fittings. RORO ships are ideal for transporting the PATRIOT system components. Typical components, features, and load capacities of patented lashings are given in figures 6-14 and 6-15.

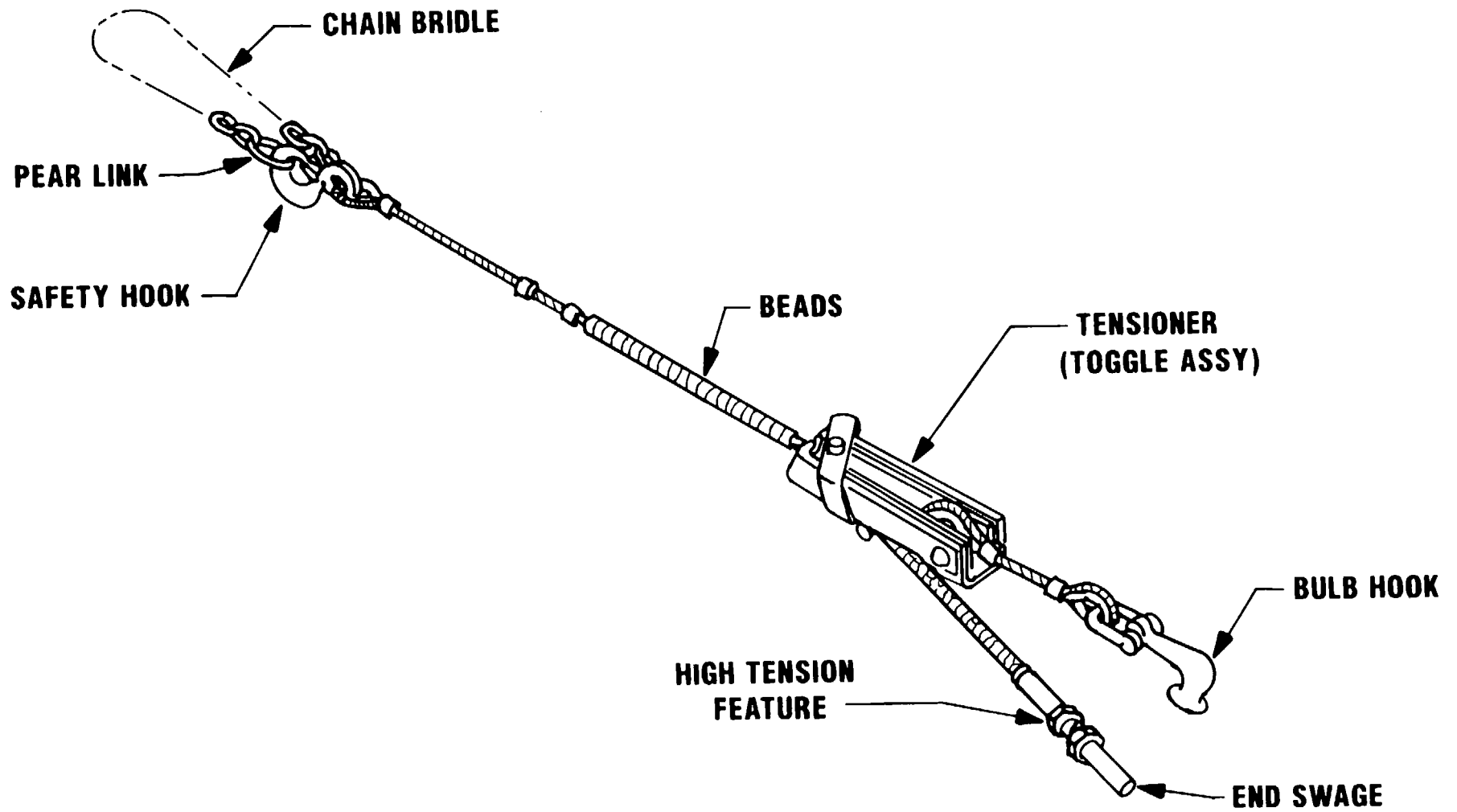

Figure 6-14. Typical Peck & Hale 9,800- and 17,000-pound-capacity patented lashing gear.

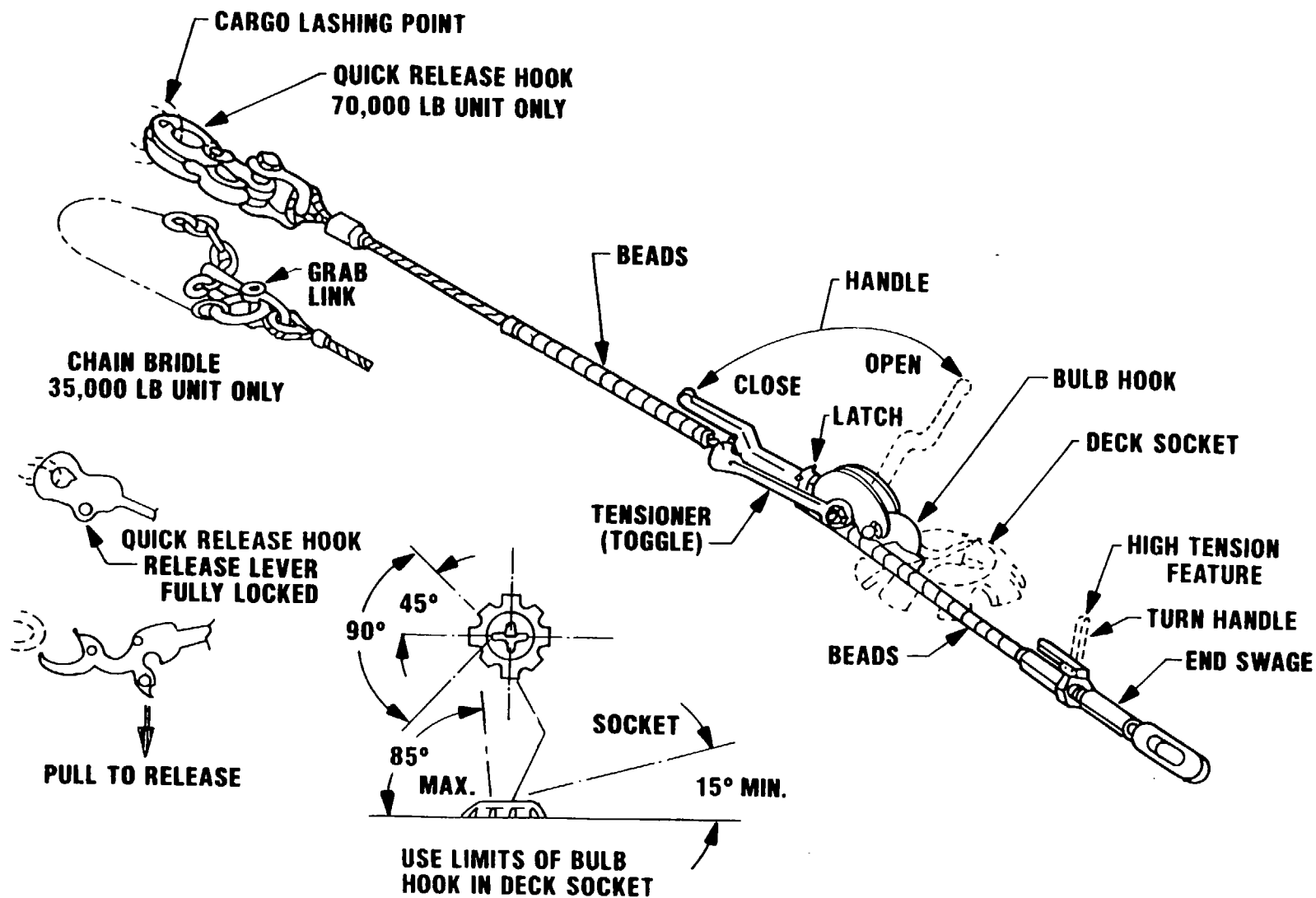

Figure 6-15. Typical Peck & Hale 35,000-and 70,000-pound-capacity patented lashing gear.

wheels and skids. Deck surfaces should be dry and free of grease and/or debris.

6-6. Barges and Lighters

The PATRIOT system components are transportable in SEABEE barges and LASH lighters, with hatch covers in place. When transported by SEABEE barges or LASH lighters, the PATRIOT components must be secured with blocking and tiedowns as shown in the figures and tables for general cargo vessel loading. Barge stability is noticeably affected by the placement of heavy items; therefore, the items should be loaded in a manner to counterbalance variations in the locations of the center of gravity. (After loading one vehicle in one end of the barge or lighter, load the second vehicle in the opposite end. Shoring is not generally used beneath vehicles equipped with rubber tires. Place shoring beneath metal

6-7. Landing Ships, Landing Craft, and Amphibious Vehicles

When the PATRIOT components are moved for extended distances or through rough waters, blocking and tiedowns must be used. When the PATRIOT components are moved to or from ships secured to piers or in sheltered anchorages, only tiedowns will be required. In most cases, the vessels are equipped with turnbuckles with a sheep's-foot on one end that fits into a deck cloverleaf and patented lashings. A suitable substitute may be used.

CHAPTER 7

RAIL TRANSPORTABILITY GUIDANCE

Section I. GENERAL

7-1. Scope.

This chapter provides rail transportability guidance for movement of the PATRIOT system. It covers technical and physical characteristics of and safety considerations for the PATRIOT system components. It also prescribes the materials and guidance required to prepare, load, tie down, and unload the PATRIOT system components.

7-2. Safety

Besides those safety precautions in chapter 3, the following items apply:

- a. The vehicles should not exceed 3 mph when on loading ramps and railcars.
- b. Guides should be in full view of the vehicle's operator.
- c. Guides should maintain a safe distance and location in front of the vehicle or on the next railcar.
- d. Cranes, gantries, outriggers, and movable parts should be secured in their shipping position with half-inch wire rope and cable clamps whether or not they have positive locking devices for movable components.

Section II. TRANSPORT ON CONUS RAILWAYS

7-3. General

The transportability guidance contained in this section applies when the PATRIOT system components are transported on CONUS railways. When loaded on a standard deck-height flatcar, the PATRIOT system components are within height and width limitations of the Association of American Railroads (AAR) "Outline Diagram for Single Loads Without End Overhang on Open-Top Cars." Therefore, they can be moved without restriction. Special preparation of some system components, such as the RS, ECS, and AMG, will be required.

7-4. Preparation for Loading

The degree of preparation for shipment depends on the operational commitment. As a minimum, the following should be accomplished.

- a. Vehicle should be in its minimum shipping configuration, as described herein.
- b. Remove and stow antennas.
- c. Remove and stow all basic issue items (BII).

7-5. Loading on General-Purpose Flatcars

a. The PATRIOT system components may be lifted onto the flatcar in the tiedown position by a crane of adequate capacity, or they may be driven or towed onto the flatcar if a suitable ramp or bridge is available. The loads presented in this chapter are based on a

minimum flatcar width of 9 feet 6 inches for all items associated with the PATRIOT system except the M373A2, LS, and RS. M373A2 semitrailers should be shipped on trailer-on-flatcar (TOFC) railcars when practical. The LS and RS require a flatcar width of 10 feet 4 inches. For rail transport, the RS is removed from the M860A1 semitrailer and the AMG and ECS are removed from the truck and placed on a flatcar. Figure 7-1 through 7-12 provide tiedown diagrams that are compatible with standard loading practices for adequate restraint. Where necessary, blocking and tiedown details are shown. The bill and application of materials for blocking and tiedown are provided in tables following the respective figures.

b. Figure 7-1 shows the typical loading of the PATRIOT system HEMTT vehicles onto general purpose flatcars. Blocking and tiedown details are shown in figure 7-2. The bill and application of materials for blocking and tiedown are provided in tables 7-1 and 7-2, respectively.

NOTE

Use a staggered nailing pattern to nail lumber or laminated lumber to the floor of a railcar. Adjust the nailing pattern for an upper piece of lumber to avoid driving a nail for that piece into a crack in the floor or against a nail in the lower piece.

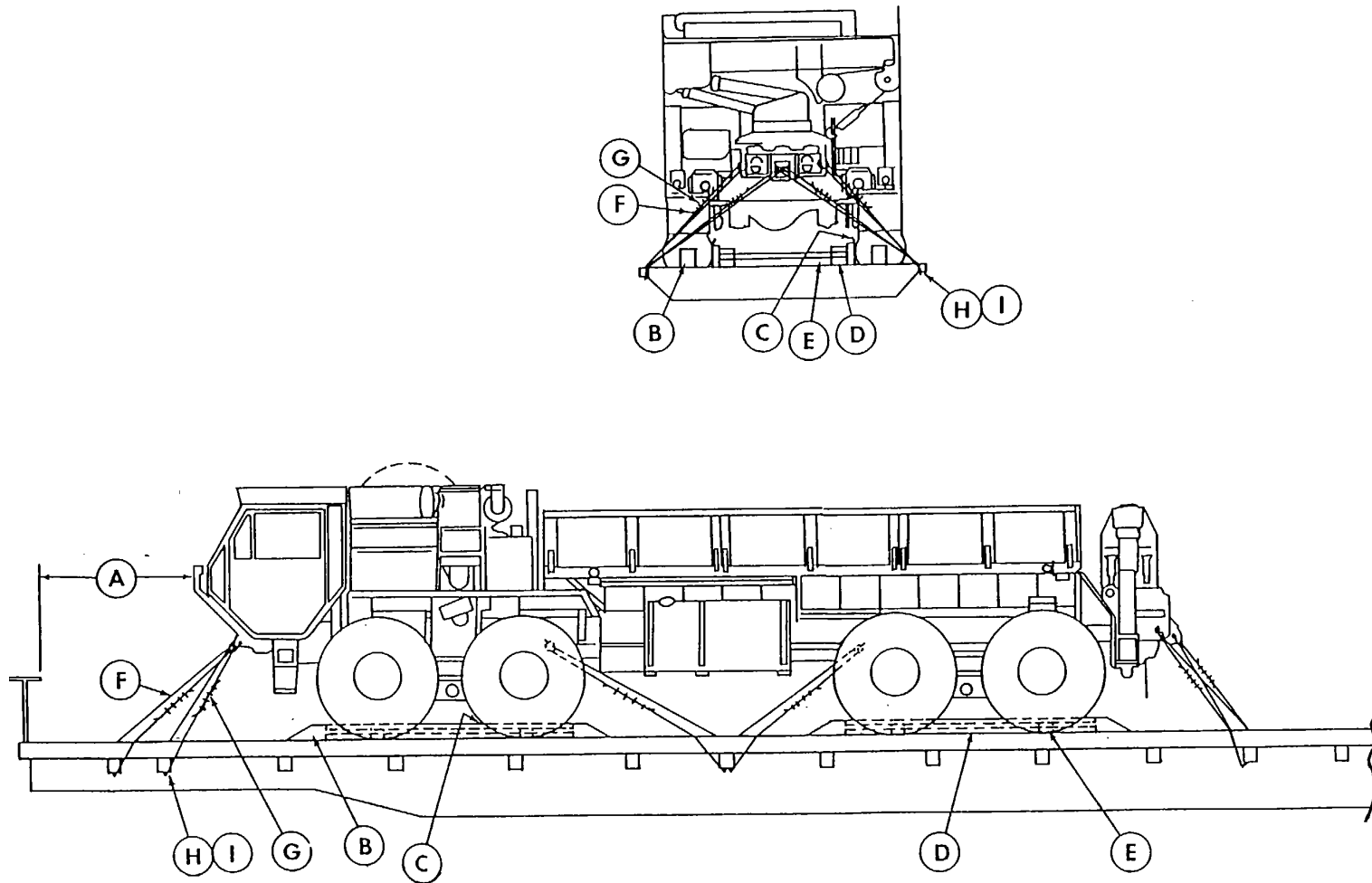

Figure 7-1. Blocking and tiedown of the M985E1, M983, or M977 vehicles on CONUS general-purpose flatcars.

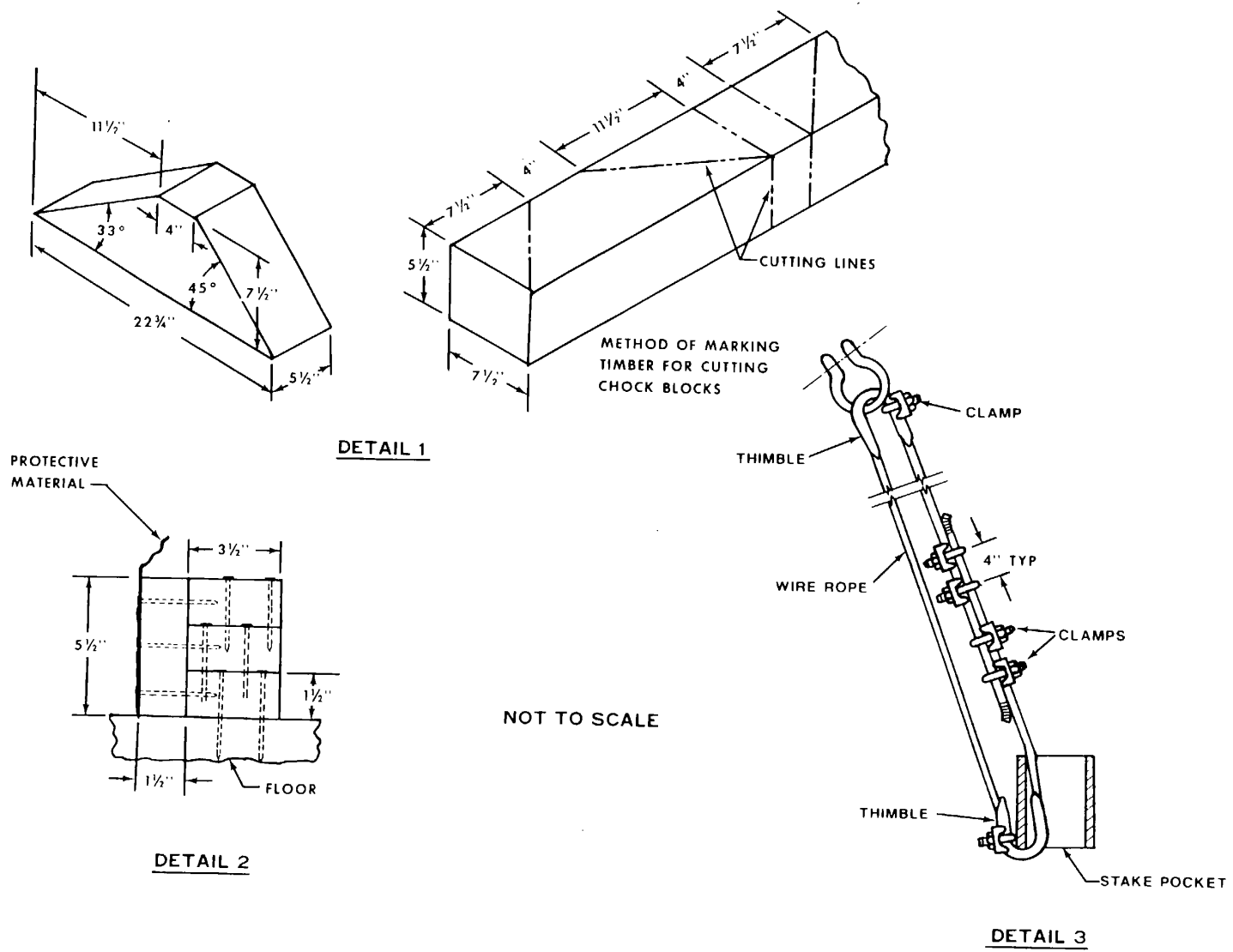

Figure 7-2. Blocking and tiedown details (fig. 7-1).

c. Figure 7-3 shows the typical loading of the PATRIOT system 5-ton trucks or truck-tractors onto general-purpose flatcars.

Table 7-1. Bills of Materials for Blocking and Tiedown of the M985E1, M983, or M977 Trucks on CONUS General-Purpose Flatcars (Figs. 7-1 and 7-2)

Item	Description	Approximate Quantity
Lumber	Douglas-fir, or comparable, straight-grain, free from material defects; Fed Spec MM-L-751: 2- x 4-inch 2- x 6-inch 6- x 8-inch	120 linear feet 60 linear feet 12 linear feet
Nails	Common, steel, flathead, bright or cement-coated; Fed Spec FF-N-105: 12d 16d 20d 40d	75 40 210 56
Thimbles	Standard, open-type, 5/8-inch	22
Clamps	Wire rope, U-bolt clips, saddled, single-grip, steel, Crosby heavy-duty, or equal; Fed Spec FF-C-450D: 5/8-inch 3/4-inch.	48 22
Wire rope.	6 x 19, IWRC; improved plow steel; performed, regular-lay; table X, Fed Spec RR-W-410C: 5/8-inch.	240 feet
Cushioning material.	Waterproof paper, burlap, or other suitable material material.	as required

Table 7-2. Application of Materials for Blocking and Tiedown of the M985E1, M983, or M977 Trucks on CONUS Flatcars (Figs. 7-1 and 7-2)

Item	No. Required	Application
A		Brake wheel clearance. Minimum clearance required is 6 inches above, in back of, and on both sides of and 4 inches underneath wheel; 12 inches from end of railcar to load, which extends from center of brake wheel to side of railcar; and 6 feet above railcar floor.
B	8	Blocks. Each consists of one piece of 6- x 8- x 24-inch lumber (detail 1, fig. 7-2). Place one block (45portion) against the front of each wheel of Nos. 1 and 3 axles and one against the rear of each wheel of Nos. 2 and 4 axles. Nail the heel of each block with three 40d nails. Toenail sides of block to railcar floor with two 40d nails on each side.

Table 7-2. Application of Materials for Blocking and Tiedown of the M985E1, M983, or M977 Trucks on CONUS Flatcars (Figs. 7-1 and 7-2)Continued

Item	No. Required	Application
C	1 per each item D.	Cushioning material. Place bottom portion under item D and between the tire and item D so that material extends 2 inches above item D.
D	4	Side blocks. Each consists of one piece of 2- x 6- x 108-inch lumber and three pieces of 2- x 4=6- x 108-inch lumber (detail 2, fig. 7-2). Nail the 2- x 6- x 108-inch piece to the side edge of one 2- x 4- x 108-inch piece with fifteen 12d nails. Place the 2- x 6- x 108-inch piece against the cushioning material and tire, and nail through the 2- x 4- x 108-inch piece to the railcar floor with twelve 20d nails. Nail the other two 2- x 4- x 108-inch pieces to the one below in the same manner, with a staggered nailing pattern to avoid striking the nail in the piece below, with twelve 20d nails.
E	4	Braces. Each consists of two pieces of 2- x 6-inch x length-cut-to-fit lumber. Place one piece between items D at the base of the tires and nail to railcar floor with eight 16d nails. Place the second piece on top of the first piece and nail with eight 20d nails.
F	12	Wire rope, 5/8-inch. Form a complete loop between tiedown shackle and the thimble (item H) of the appropriate stake pocket at a maximum angle of 45° (detail 3, fig. 7-2). Ends of wire rope should overlap about 24 inches.
G	48	Clamps, 5/8-inch. Place four clamps on each item F at the overlap area. Space clamps 4 inches apart.
H	22	Thimbles, 5/8-inch. Place one thimble between the wire rope and tiedown shackle (none on pintle).
I	22	Clamps, 3/4-inch. Place one clamp on each item H (detail 3, fig. 7-2).

GENERAL INSTRUCTIONS

Loading rules, 1A, 2, 3, 4, 5, 7, 9, 12, 13, 14, 15, 19, 19A, 19B, and 19C appearing in section 1 of the General Rules Governing the Loading of Commodities on Open-Top Cars, published by the Association of American Railroads, provide applicable guidelines and are mandatory in application.

NOTE

Tension wire rope using a chain hoist with two cable grippers. Tension to allow no more than 1-inch deflection when sup-

porting the weight of a full grown man. Torque clamps as follows:

3/8-inch clamp, 45 foot-pounds

1/2-inch clamp, 65 foot-pounds

5/8-inch clamp, 95 foot-pounds

Blocking and tiedown details are shown in figure 7-2.

The bill and application of materials for

blocking and tiedown are provided in tables 7-3 and 7-4, respectively.

CAUTION

For vehicles loaded onto general-purpose flatcars, wire-tie the gearshift lever in neutral and set the parking brakes.

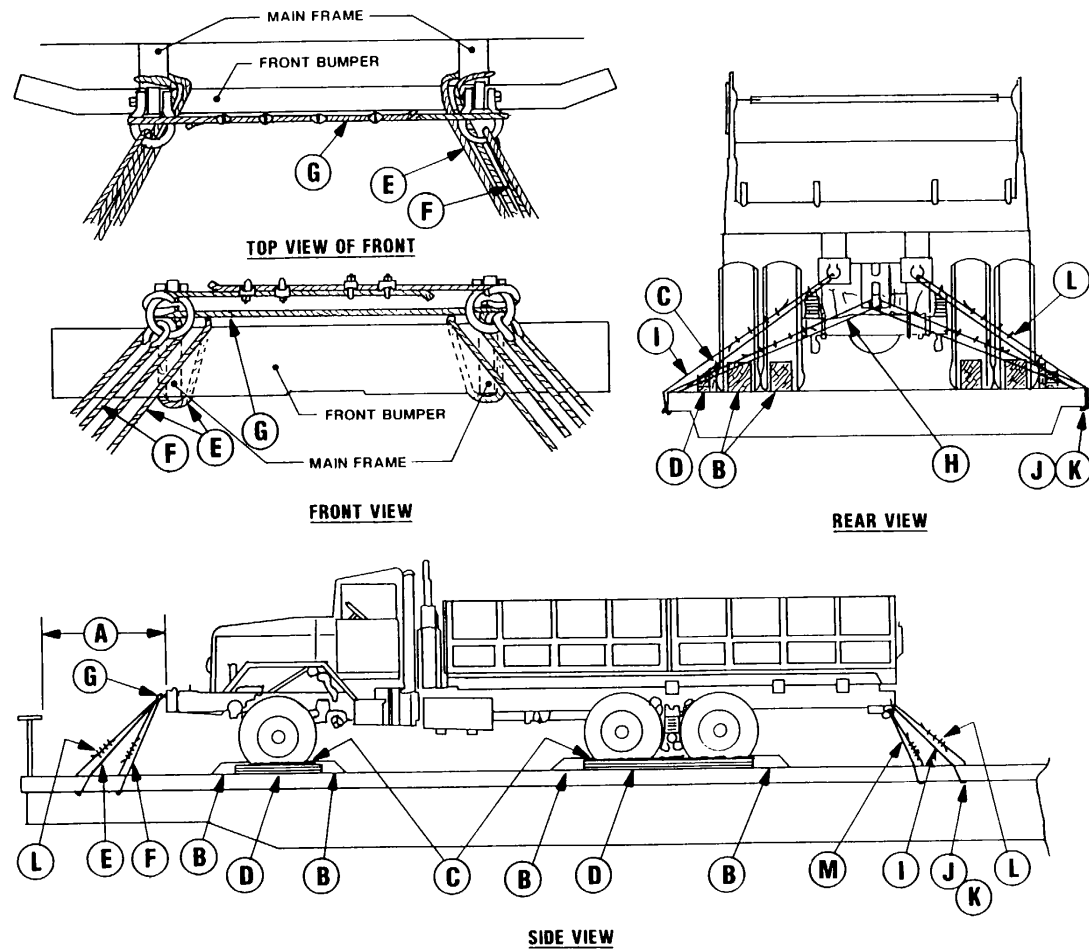

Figure 7-3. Blocking and tiedown of the M927, M942, M931, or M932 5-ton trucks on CONUS general-purpose flatcars.

d. Figure 7-4 shows the typical loading of the PATRIOT system van-type semitrailer-mounted components on general-purpose flatcars. Figure 75 shows construction of the forward support blocking

assembly. The bill and application of materials for blocking and tiedown are provided in tables 7-5 and 7-6, respectively.

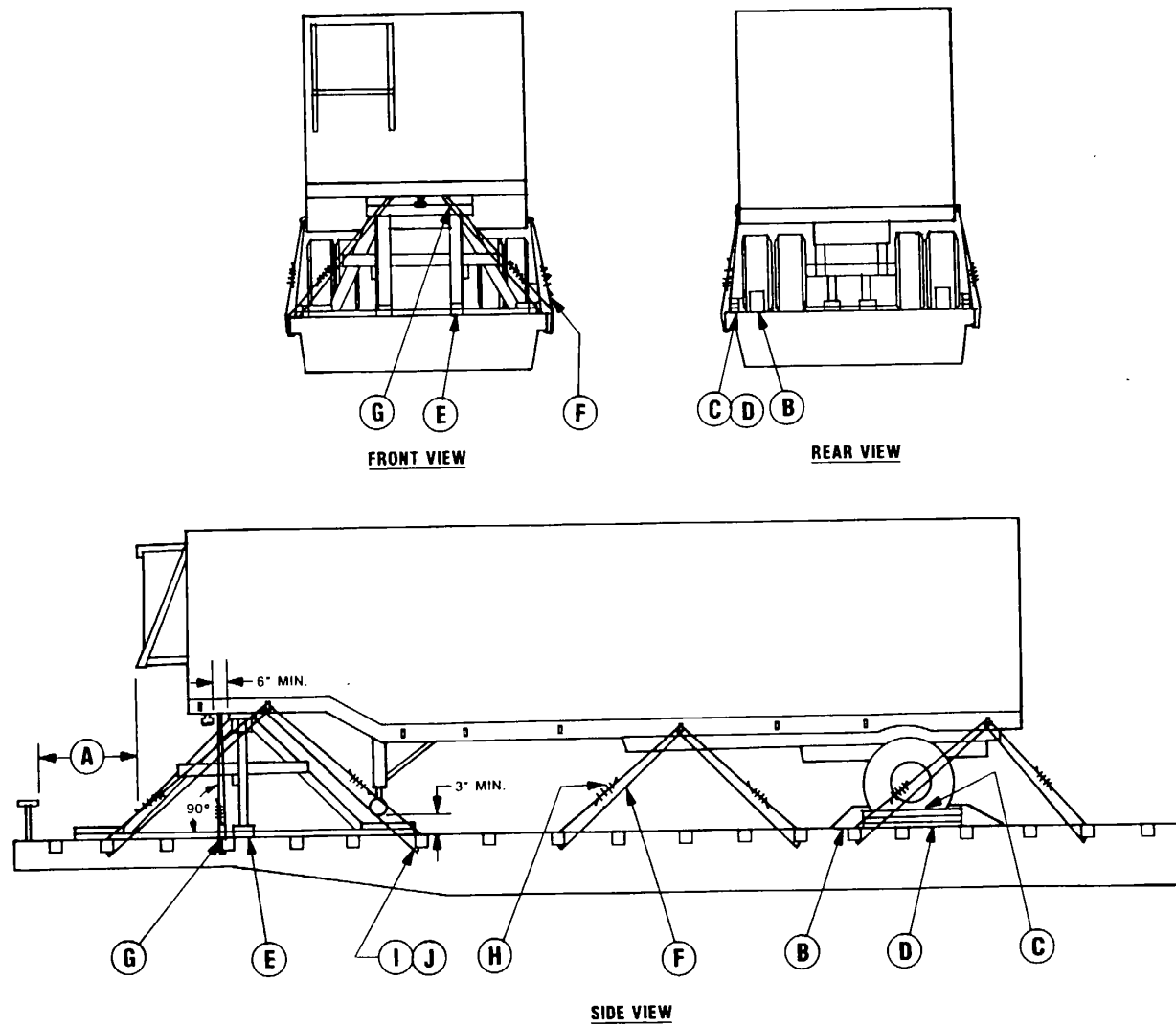
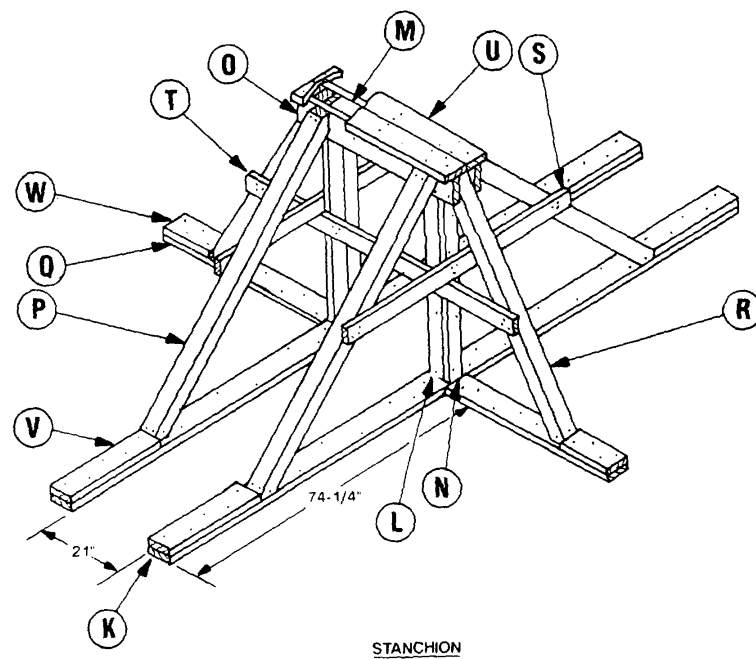

Figure 7-4. Blocking and tiedown of the PATRIOT system van-type semitrailer-mounted components on CONTUS general-purpose faltcars.



STANCHION

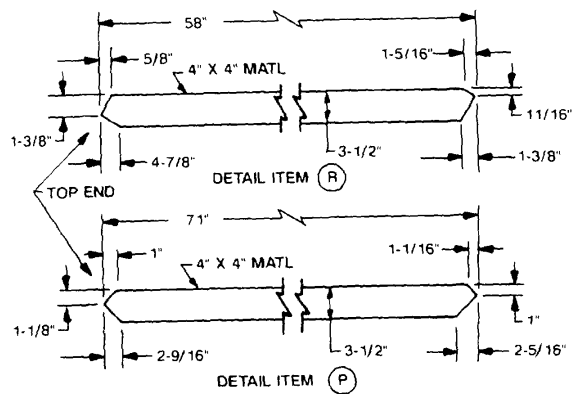

Figure 7-5. Forward support blocking assembly for van-type semitrailer-mounted components.

e. Figure 7-6 shows the typical loading of the PATRIOT system trailer-mounted components, including the EPU II, on general-purpose flatcars. Figure 7-7 shows construction of the forward sup-

port blocking assembly. The bill and application of materials are provided in tables 7-7 and 7-8, respectively.

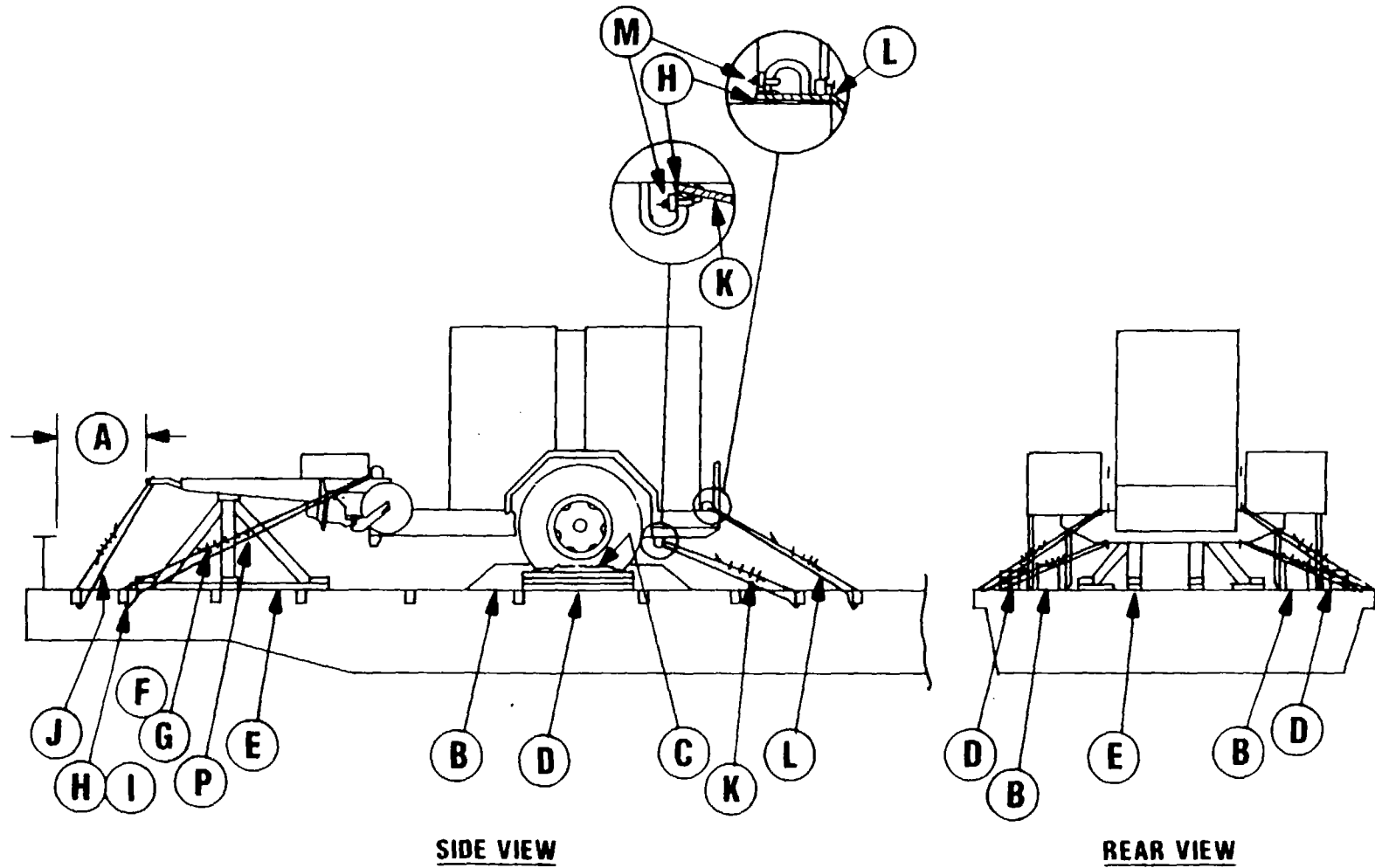

Figure 7-6. Blocking and tiedown of the PATRIOT system trailer-mounted components on CONUS general-purpose fatcars.

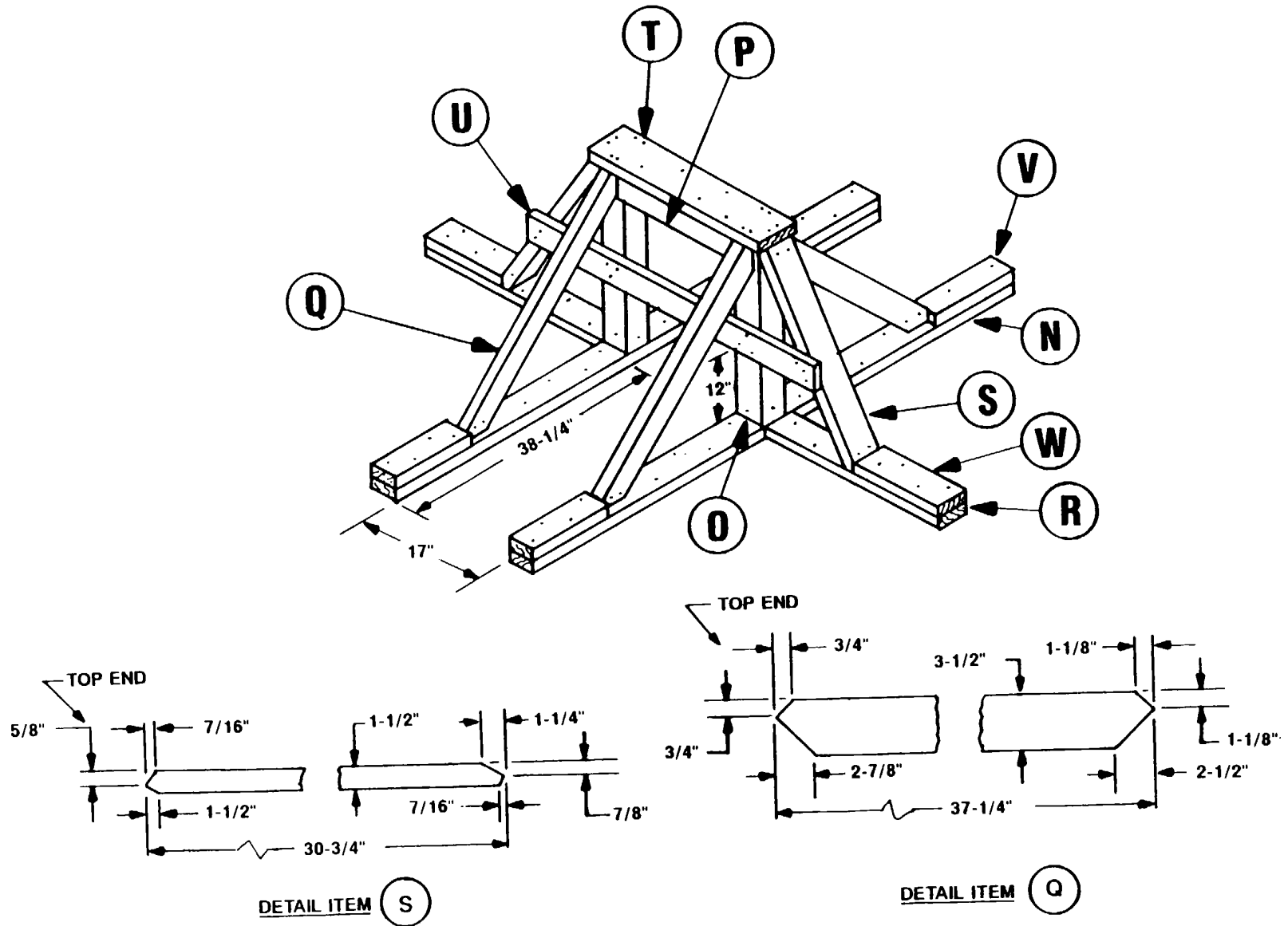

Figure 7-7. Forward support blocking assembly for trailer-mounted components.

f. Figure 7-8 shows the typical loading of the M860A1 semitrailer with the LS, outriggers, and generator on CONUS general-purpose flatcars. This load also applies to the M860A1 with the RS removed and outriggers in place. The bill and application of materials are provided in tables 7-9 and 7-10, respectively.

NOTE

The RS is not to be mounted on the M860A1 when transported by rail. See figure 7-9 for transporting the RS by rail.

Table 7-3. Bill of Materials for Typical Blocking and Tiedown of the 5-Ton Trucks and Truck-Tractors Used in the PATRIOT Missile System on CONUS General-Purpose Flatcars (Figs 7-2 and 7-3)

Item Quantity	Description	Approximate
Lumber	Douglas-fir, or comparable, straight-grain, free from material defects; Fed Spec MM-L-751H: 2- x 4-inch 2- x 6-inch 6- x 8-inch	60 linear feet 20 linear feet 20 linear feet
Nails	Common, steel; flathead; bright or cement-coated; Fed Spec FF-N-105: 12d 20d 40d	38 114 84
Thimbles	Standard, open-type: 5/8-inch	14
Clamps	Wire rope, U-bolt clips, saddled, single-grip, steel, Crosby heavy-duty or equal; Fed Spec FF-C-450D: 5/8-inch 3/4-inch.	45 14
Wire rope.	6 x 19, IWRC; improved plow steel; preformed, regular-lay; table X, Fed Spec RR-W-410C: /5/8-inch.	240 feet
Cushioning material.	Waterproof paper, burlap, or as required other suitable material.	

Table 7-4. Application of Materials for Typical Blocking and Tiedown of the 5-Ton Trucks and Truck-Tractors Used in the PATRIOT Missile System on CONUS General-Purpose Flatcars (Figs 7-2 and 7-3)

Item	No. Required	Application
A		Brake wheel clearance. Minimum clearance required is 6 inches above, in back of, and on both sides of and 4 inches underneath wheel; 12 inches from end of railcar to load, which extends from center of brake wheel to side of railcar; and 6 feet above railcar floor.
B	12	Blocks. Each consists of one piece of 6- x 8- x 24-inch lumber (detail 1, fig 7-2). Place one block (45° portion) against the front of each wheel of Nos. 1 and 2 axles and one against the rear of each wheel of Nos. 1 and 3 axles. Nail the heel of each block with three 40d nails. Toenail sides of block to railcar floor with two 40d nails on each side.
C	1 per each item D.	Cushioning material. Place bottom portion under item D and between the tire and item D so that material extends 2 inches above item D.
D	4	Side blocks. Two for the outside of the rear bogie tires, 84-inch lumber. Two for the outside of front tires, 36-inch lumber. The two rear blocks consists of one piece of 2- x 6- x 84-inch lumber and three pieces of 2- x 4- x 84-inch lumber (detail 2, fig 7-2). Nail the 2- x 6- x 84-inch piece to the side edge of one 2- x 4- x 84-inch piece with thirteen 12d nails. Place the 2- x 6- x 84-inch piece against the cushioning material and tire, and nail through the 2- x 4- x 84-inch to the railcar floor with twelve 20d nails. Nail the other two 2- x 4- x 84-inch pieces to the one below in the same manner, with a staggered nailing pattern to avoid striking the nail in the piece below, with twelve 20d nails. The two front blocks consists of one piece of 2- x 6- x 36-inch lumber and three pieces of 2- x 4- x 36-inch lumber. Nail in place, as described above for the rear blocks, with a 6-inch-spaced staggered nailing pattern.
*E	2	Wire rope, 5/8-inch. Form a complete loop by placing the wire rope around the inner side of the lifting shackle mount, down and under the main frame, up over the bumper, and through a thimble (item J) at a stake pocket at a maximum angle of 45° (detail 3, fig 7-2). Ends of the wire rope should overlap about 24 inches.

Table 7-4. Application of Materials for Typical Blocking and Tiedown of the 5-Ton Trucks and Truck-Tractors Used in the PATRIOT Missile System on CONUS General-Purpose Flatcars (Figs 7-2 and 7-3)-Continued

Item	No. Required	Application
F	2	Wire rope, 5/8-inch. Form a complete loop between the tiedown shackle and a thimble (item J) at the appropriate stake pocket at a maximum angle of 45°. Ends of the wire rope should overlap about 24 inches.
G	1	Wire rope, 5/8-inch. Form a complete loop around the outside of the tiedown shackles at the front bumper (fig 7-3).
H	2	Wire rope, 5/8-inch. Form a complete loop through the pintle to a thimble at a stake pocket at a maximum angle of 45°. Ends of wire rope should overlap about 24 inches.

Table 7-4. Application of Materials for Typical Blocking and Tiedown of the 5-Ton Trucks and Truck-Tractors Used in the PATRIOT Missile System on CONUS General-Purpose Flatcars (Figs 7-2 and 7-3)-Continued

Item	No. Required	Application
1	12	Wire rope, 5/8-inch. Form a complete loop through the tiedown fitting under the bumperettes to a thimble at a stake pocket at a maximum angle of 45°. Ends of wire rope should overlap about 24 inches.
J	14	Thimbles, 5/8-inch. Place one thimble between the wire rope and tiedown shackles and stake pockets (none on pintle).
K	14	Clamps, 3/4-inch. Place one clamp on each item J (detail 3, fig 7-2).
L	36	Clamps, 5/8-inch. Place four clamps on each item E, F, G, H, and I at the overlap area. Space clamps 4 inches apart.

GENERAL INSTRUCTIONS

Loading rules 1A, 2, 3, 4, 5, 7, 9, 13, 14, 15, 19, 19A, 19B, and 19C appearing in section 1 of the *General Rules Governing the Loading of Commodities on Open-Top Cars*, published by the Association of American Railroads, provide applicable guidelines and are mandatory in application.

NOTE

Tension wire rope using a chain hoist with two cable grippers. Tension to allow no more than 1-inch deflection when supporting the weight of a full grown man. Torque clamps as follows:

- 3/4-inch clamp, 45 foot-pounds
- 1/2-inch clamp, 65 foot-pounds
- 5/8-inch clamp, 95 foot-pounds

Table 7-5. Bill of Materials for Blocking and Tiedown of the PATRIOT System Van-Type Semitrailer-Mounted Components on CONUS General-Purpose Flatcars (Figs 7-4 and 7-5)

Item	Description	Approximate Quantity
Lumber	Douglas-fir, or comparable, straight-grain, free from material defects; Fed Spec MM-L-751H: 2- x 4-inch 2- x 6-inch 4- x 4-inch 6- x 8-inch	40 linear feet 80 linear feet 50 linear feet 7 linear feet
Nails	Common, steel; flathead; bright or cement-coated; Fed Spec FF-N-105: 12d 16d 20d	85 65 80

Table 7-5. Bill of Materials for Blocking and Tiedown of the PATRIOT System Van-Type Semitrailer-Mounted Components on CONUS General-Purpose Flatcars (Figs 7-4 and 7-5) - Continued

Item	Description	Approximate Quantity
Thimbles	30d 40d	60 40
Wire rope.	Standard, open-type, 5/8-inch 6 x 19, IWRC; improved plow steel performed, regular-lay; table X, Fed Spec RR-W-410C: 5/8-inch.	28 140 feet
Clamps	Wire rope, U-bolt clips, saddled, single-grip, steel, Crosby heavy-duty or equal; Fed Spec FF-C-450D: 5/8-inch 3/4-inch	56 28
Cushioning material.	Waterproof paper, burlap, or other suitable material.	as required
Tiedown ring.	Tiedown rings for semitrailer frame; 10,000-pound-capacity, NSN 4010-01-058-4772; 25,000-pound-capacity, NSN 4010-01-058-4771.	6

Table 7-6. Application of Materials for Typical Blocking and Tiedown of PATRIOT Van-Type Semitrailer-Mounted Components on CONUS General-Purpose Flatcars (Figs 7-2, 7-4, and 7-5)

	No. Item	Required Application
A		Brake wheel clearance. Minimum clearance required is 6 inches above, in back of, and on both sides of and 4 inches underneath wheel; 12 inches from end of railcar to load, which extends from center of brake wheel to side of railcar; and 6 feet above railcar floor.
B	4	Blocks. Each consists of one piece of 6- x 8- x 24-inch lumber (detail 1, fig 7-2). Place one block (45 x portion) against the front and rear of each outside wheel, Nail the heel of each block with three 40d nails. Toenail sides of block to railcar floor with two 40d nails on each side.
C	as required	Cushioning material. Place bottom portion under item D and between the tire and item D so that the material extends 2 inches above item D.
D	2	Side blocks. Each consists of one piece of 2- x 6- x 36-inch lumber and three pieces of 2- x 4- x 36-inch lumber (detail 2, fig 7-2). Nail the 2- x 6- x 36-inch piece to the side edge of one 2- x 4- x 36-inch piece with five 12d nails. Place the 2- x 6- 36-inch piece against the cushioning material and tire, and nail through the 2- x 4- x 36-inch piece to the railcar floor with five 20d nails. Nail the other two 2- x 4- x 36-inch pieces to the one below in the same manner. Use a staggered nailing pattern to avoid striking the nail in the piece below. Nail each piece with five 30d nails.
E	1	Forward support blocking assembly. Construct off railcar and place 6 inches behind kingpin of semitrailer. Details for construction are shown in figure 7-5 and items K through W below. Retract landing gear at least 3 inches from the railcar.
F	12	Wire rope, 5/8-inch. (Install tiedown rings furnished with semitrailer in receptacles shown in fig 7-4.) Form a complete loop between tiedown ring and thimble (item 1) at the appropriate stake pocket at a maximum angle of 45° (detail 3, fig 7-2). Ends of wire rope should overlap about 24 inches.

Table 7-6. Application of Materials for Typical Blocking and Tiedown of PATRIOT Van-Type Semitrailer-Mounted Components on CONUS General-Purpose Flatcars (Figs 7-2, 7-4, and 7-5C-continued)

Item	No. Required	Application
G	2	Wire rope, 5/8-inch. Form a complete loop between frame or fittings forward of the fifth wheel plate and a thimble at the nearest stake pocket on the railcar, as close to 90° as practical.
H	56	Clamps, 5/8-inch. Place four clamps on each item F and G at the overlap area. Space clamps 3/4 inches apart.
L	32	Thimbles, 5/8-inch. Place one thimble over the wire rope at the bottom edge of the stake pocket, tiedown ring, and any sharp radius. Secure the thimble to the wire rope with one 3/4 inch clamp, item J.
J	32	Clamps, 3/4-inch. Place one on each item I. CAUTION Tension wire ropes, item F and G, to cause a slight (1-2- to 3/4-inch) vehicle body spring deflection at rear and a firm contact of fifth wheel plate on the forward blocking. Then tighten clamps, item H, to 95 foot-pounds torque.
K	2	<i>Construction of item E</i> Lumber, 2- x 6- x 152-inch. Nail to railcar floor with 8inch staggered nailing pattern. Place pieces so that they will be parallel to the centerline of the railcar floor and 21 inches apart.
L	2	Lumber, 4- x 4- x 48-inch. Place vertical pieces 74-1/4 inches from the forward end of item K and toenail with four 16d nails.
M	1	Lumber, 4- x 4- x 28-inch. Place across top ends of items L and toenail with four 16d nails in each end.
N	2	Lumber, 2- x 4- x 31 1/2-inch. Place outside of items L and M and on item K. Nail to items L, M, and K with five 12d nails.
O	2	Lumber, 2- x 6- x 42-inch. Place even with the top of item M, with equal extension beyond items N on each side, and nail with four 12d nails.
P	4	Lumber, 4- x 4- x 71-inch. Cut ends as shown in detail item P, figure 7-5. Place top end even with top edge of item O and toenail to item O with two 16d nails. Toenail bottom end to item K with three 16d nails before placing and nailing items.
Q	2	Lumber, 2- x 6- x 38-inch. Center beside item N and toenail to item K with two 12d nails, one in each side.

Table 7-6. Application of Materials for Typical Blocking and Tiedown of PATRIOT Van-Type Semitrailer-Mounted Components on CONUS General-Purpose Flatcars (Figs 7-2, 7-4, and 7-5-Continued)

Item	No. Required	Application
R	2	Lumber, 4- x 4- x 58-inch. Cut ends as shown in detail item R, figure 7-5. Place top end even with top edge of items M and O and toenail with two 16d nails. Toenail bottom end to item Q with three 16d nails.
S	2	Lumber, 2- x 4- x 70-inch. Nail horizontally to items P and N, about 24 inches from the floor, with three 12d nails in each item P and N.
T	1	Lumber, 2- x 4- x 68-inch. Place beneath items S and nail to items L and R with three 12d nails in each item L and R.
U	2	Lumber, 2- x 6- x 42-inch. Place on top of items M, O, P, and R, covering half of item M, and nail with two 12d nails in each P and R and four 12d nails in each M and O. After placement on railcar at least 6 inches behind kingpin and a 21-inch space between items K centered lengthwise the railcar, nail items K and Q with 20d nails in an 8-inch staggered nailing pattern.
V	4	Lumber, 2- x 6- x 24-inch. Place firmly against item P and nail to item K with six 30d nails.
W	2	Lumber, 2- x 6- x 12-inch. Place firmly against item R and nail to item Q with four 30d nails.

GENERAL INSTRUCTIONS

1. Loading rules 1A, 2, 3, 4, 5, 7, 9, 12, 13, 14, 15, 19, 19A, 19B, and 19C appearing in section 1 of *General Rules Governing the Loading of Commodities on Open-Top Cars*, published by the Association of American Railroads, provide applicable guidelines and are mandatory in application.

2. Forward support blocking, item E, should be preassembled except for items V and W. Position item E at least 6 inches behind kingpin and nail to railcar, and then nail items V and W in place.

NOTE

Tension wire rope using a chain hoist with two cable grippers. Tension to allow no more than 1 inch deflection when supporting the weight of a full grown man. Torque clamps as follows:
3/8-inch clamp, 45 foot-pounds
1/2-inch clamp, 65 foot-pounds
5/8-inch clamp, 95 foot-pounds

Table 7-7. Bill of Materials for Blocking and Tiedown of the PATRIOT System Trailer-Mounted Components on CONUS General-Purpose Flatcars (Figs 7-6 and 7-7)

Item	Description	Approximate Quantity
Lumber	Douglas-fir, or comparable, straight-grain, free from material defects; Fed Spec MM-L-751H: 2- x 4-inch . 2- x 6-inch . 4- x 4-inch . 4- x 8-inch .	70 linear feet 10 linear feet 7 linear feet 8 linear feet
Nails	Common, steel; flathead; bright or cement-coated; Fed Spec FF-N-105: 12d 16d 20d 30d 40d	40 110 15 60 40
Thimbles	Standard, open-type, Y2-inch	16
Wire rope.	6 x 19, IWRC; improved plow steel preformed, regular-lay; table X, Fed Spec RR-W-410C: 1/2-inch.	240 feet
Clamps	Wire rope, U-bolt clips, saddled, single-grip, steel, Crosby heavy-duty or equal; Fed Spec FF-C-450D:. 1/2-inch 5/8-inch 7/8-inch	32 16 4
Cushioning material.	Waterproof paper, burlap, or other suitable material.	as required

Table 7-8. Application of Materials for Blocking and Tiedown of the PATRIOT System Trailer-Mounted Components on CONUS General-Purpose Flatcars (Figs 7-2, 7-6, and 7-7)

Item	No. Required	Application
A		Brake wheel clearance. Minimum clearance required is 6 inches above, in back of, and on both sides of and 4 inches underneath wheel; 12 inches from end of railcar to load, which extends from center of brake wheel to side of railcar; and 6 feet above railcar floor.
B	4	Blocks. Each consists of one piece of 6- x 8- x 24-inch lumber (detail 1, fig. 7-2). Place one block (45 portion) against the front and rear of each wheel on the main axle. Nail the heel of each block with three 40d nails. Toenail sides of block to railcar floor with two 40d nails on each side.

Table 7-8. Application of Materials for Blocking and Tiedown of the PATRIOT System Trailer-Mounted Components on CONUS General-Purpose Flatcars (Figs 7-2, 7-6, and 7-7)-Continued

Item	No. Required	Application
C	as required	Cushioning material. Place bottom portion under item D and between the tire and item D so that the material extends 2 inches above item D.
D	2	Side blocks. Each consists of one piece of 2- x 6- x 36-inch lumber and three pieces of 2- x 4- x 36-inch lumber (detail 2, fig. 7-2). Nail the 2- x 6- x 36-inch piece to the side edge of one 2- x 4- x 36-inch piece with five 12d nails. Place the 2- x 6- x 36-inch piece against the cushioning material and nail through the 2- x 4- x 36-inch piece to the railcar floor with five 20d nails. Nail the other two 2- x 4- x 36-inch pieces to the one below in the same manner. Use a staggered nailing pattern to avoid striking the nail in the piece below. Nail each piece with five 30d nails.
E	1	Forward blocking assembly. Construct off railcar and place 12 inches aft of the lunette mounting. Details for construction are shown in sketch 1, figure 7-7 and items N through U below. Retract landing gear, and rotate and lock in towing position.
F	2	Wire rope, 1/2-inch. Form a complete loop between the forward lift/tiedown fitting and thimble (item H) at the appropriate stake pocket at a maximum angle of 30° (detail 3, fig. 7-2). Ends of wire rope should overlap about 24 inches.
G	32	Clamps, 1/2-inch. Place four clamps on each item F, J, K, and L at the overlap area. Space clamps 4 inches apart.
H	16	Thimble, 1/2-inch. Place between the wire rope and tiedown points on trailer and railcar stake pockets. Secure the thimble to the wire rope with one 5/8-inch clamp, item I.
I	16	Clamp, 5/8-inch. Place one on each item H.
J	2	Wire rope, 1/2-inch. Form a complete loop between lunette and appropriate stake pocket at a maximum angle of 30°.
K	2	Wire rope, 1/2-inch. Form a complete loop between the rear tiedown provision and the appropriate stake pocket at a maximum angle of 30°. Before tensioning tiedown, place item M on the aft leg of the tiedown provision, holding wire rope and thimble as close to the frame as possible.

Table 7-8. Application of Materials for Blocking and Tiedown of the PATRIOT System Trailer-Mounted Components on CONUS General-Purpose Flatcars (Figs 7-2, 7-a, and 7-7)- Continued

Item	No. Required	Application
L	2	Wire rope, 1/2-inch. Form a complete loop between the rear lift/tiedown provision and the appropriate stake pocket at a maximum angle of 30°. Before tensioning tiedown, place item M on the forward leg of the provision, holding wire rope and thimble as close to the frame as possible. Thread wire rope outside of the aft leg to prevent damage to the aft work platform mount.
M	4	Clamp, 7/8-inch. Place on provisions in items K and L. <i>Construction of Item E.</i>
N	2	Lumber, 2- x 4- x 80-inch. Place pieces so that they will be parallel to the centerline of the railcar floor, 17 inches apart.
O	2	Lumber, 4- x 4- 23-1/4-inch. Place vertical pieces 38-1/4-inches from the forward end of item N and toenail with four 16d nails.
P	1	Lumber, 4- x 4- x 24-inch. Place across top ends of item O and toenail with four 16d nails in each end.
Q	4	Lumber, 2- x 4- x 37-1/4-inch. Double-bevel each end (detail item Q, fig 7-7). Toenail to item P with two 16d nails and to item N with four 16d nails.
R	2	Lumber, 2- x 4- x 27-1/2-inch. Place against item N, centered under item O, and toenail with two 12d nails.
S	2	Lumber, 2- x 4- x 30 3/4-inch. Double-bevel each end (detail item S, fig 7-7). Toenail to item P with two 16d nails and item R with four 16d nails.
T	1	Lumber, 2- x 6- x 27-inch. Nail to item P with five 12d nails and items Q and S with two 12d nails each.
U	1	Lumber, 2- x 4- x 42-inch. Place 12 inches above item N and nail to items O and S with three 12d nails in each. Place assembly on railcar, in position, and nail items N and R to floor with twenty-four 16d nails spaced 8 inches apart.
V	4	Lumber, 2- x 4- x 12-inch. Place against item Q and on top of item N and nail with four 30d nails.
W	2	Lumber, 2- x 4- x 12-inch. Place against item S and on top of item R and nail with four 30d nails.

GENERAL INSTRUCTIONS

1. Loading rules 1A, 2, 3, 4, 5, 7, 9, 12, 13, 14, 15, 19, 19A, 19B, and 19C appearing in section 1 of the *General Rules Governing the Loading of Commodities on Open-Top Cars*, published by the Association of American Railroads, provide applicable guidelines and are mandatory in application.
2. Forward blocking, item E, should be preassembled, except for items V and W. Position item E 12 inches aft of lunette mount and nail to railcar, and then nail items V and W in place.

NOTE

Tension wire rope using a chain hoist with two cable grippers.

Tension to allow no more than 1-inch deflection when supporting the weight of a full grown man. Torque clamps as follows:

3/8-inch clamp, 45 foot-pounds

1/2-inch clamp, 65 foot-pounds

5/8-inch clamp, 95 foot-pounds

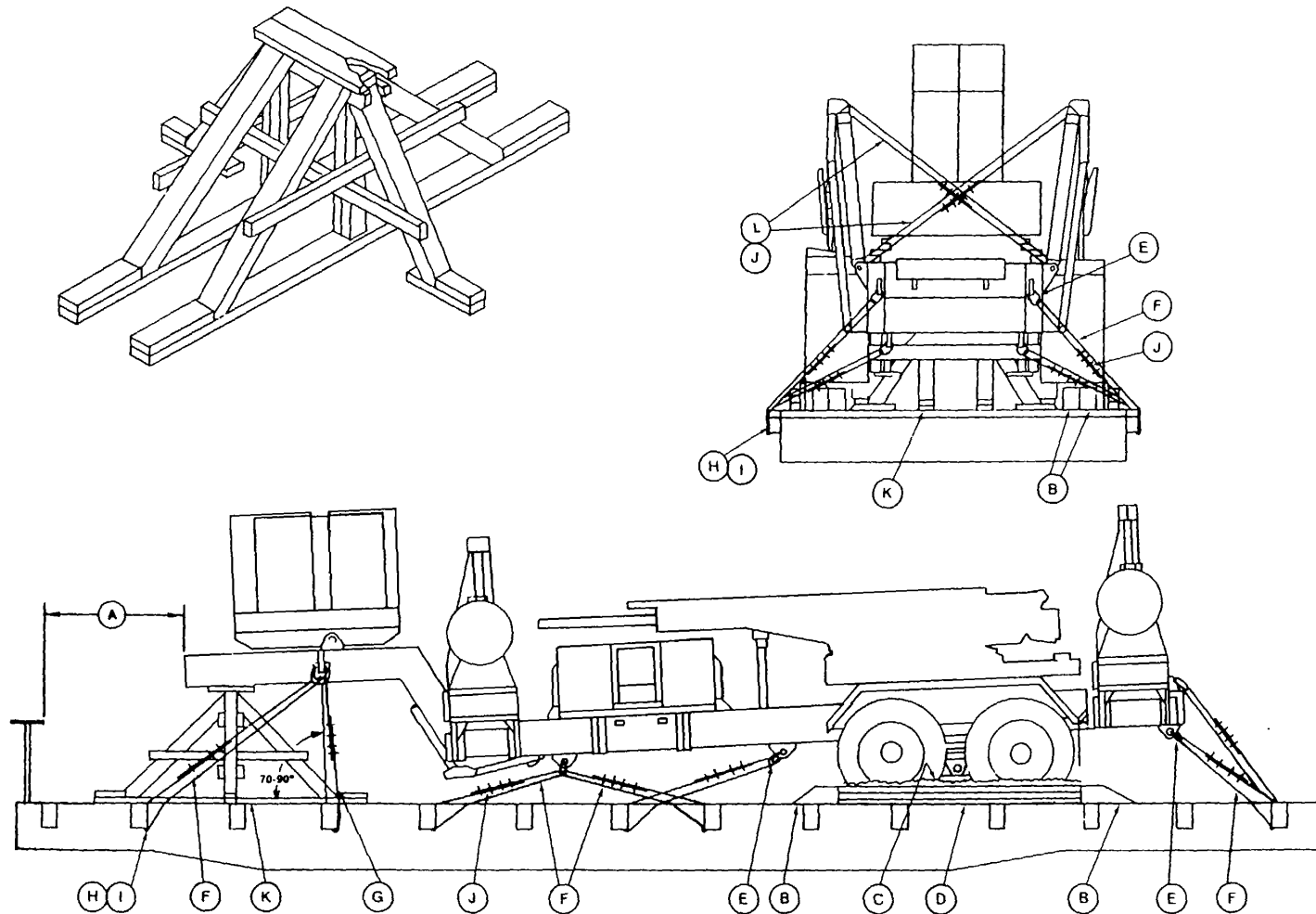

Figure 7-8. Blocking and tiedown of the M860A1 semitrailer with the LS, outriggers, and generator, or with the RS removed and the outrigger in place on CONUS general-purpose flatcars.

g. Figure 7-9 identifies the special blocking and tiedown required for transport of the RS on CONUS general-purpose flatcars. Blocking detail

is shown in figure 7-10. The bill and application of materials are provided in tables 7-11 and 7-12, respectively.

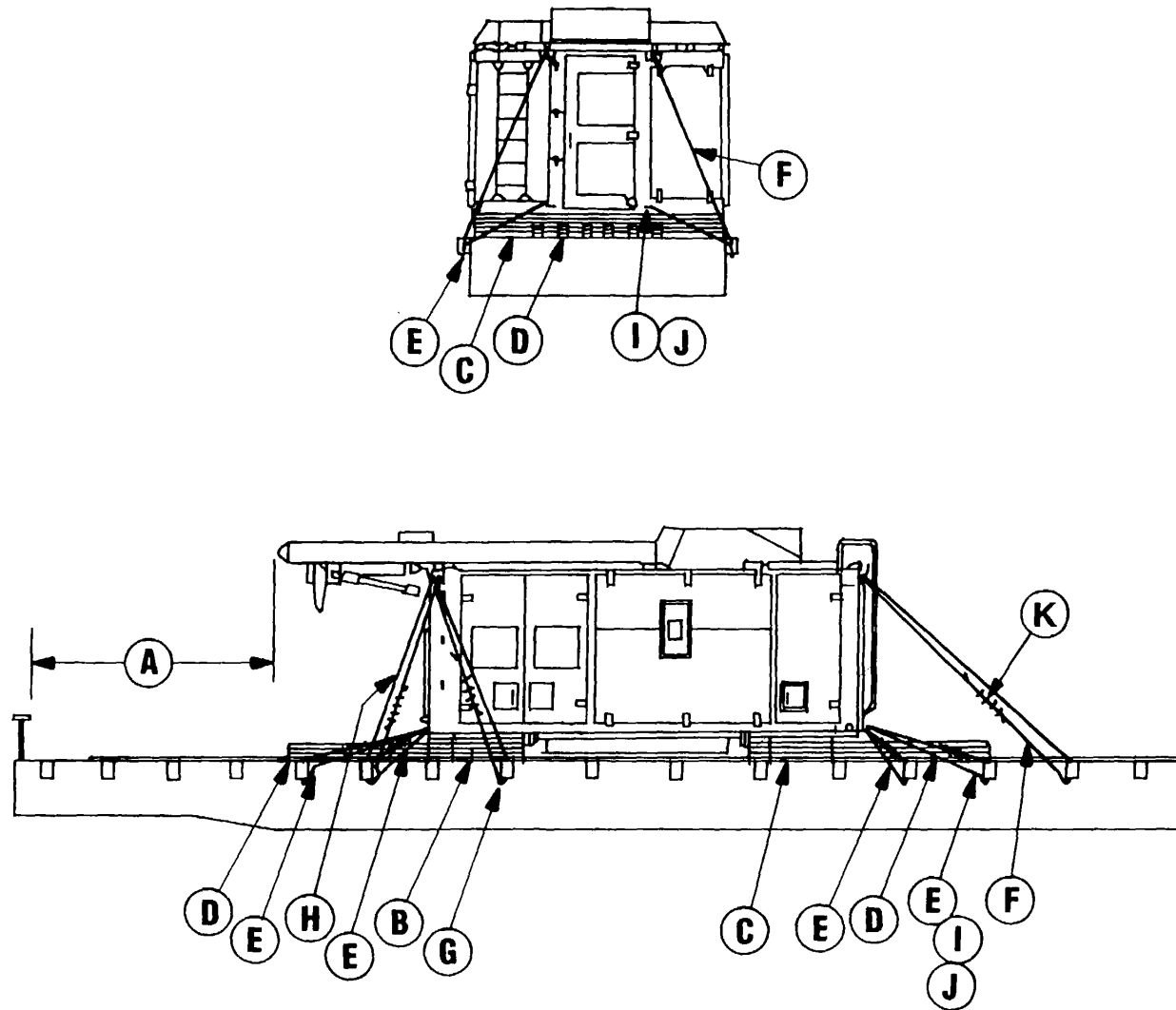

Figure 7-9. Blocking and tiedown of the RS on CONUS general-purpose flatcars.

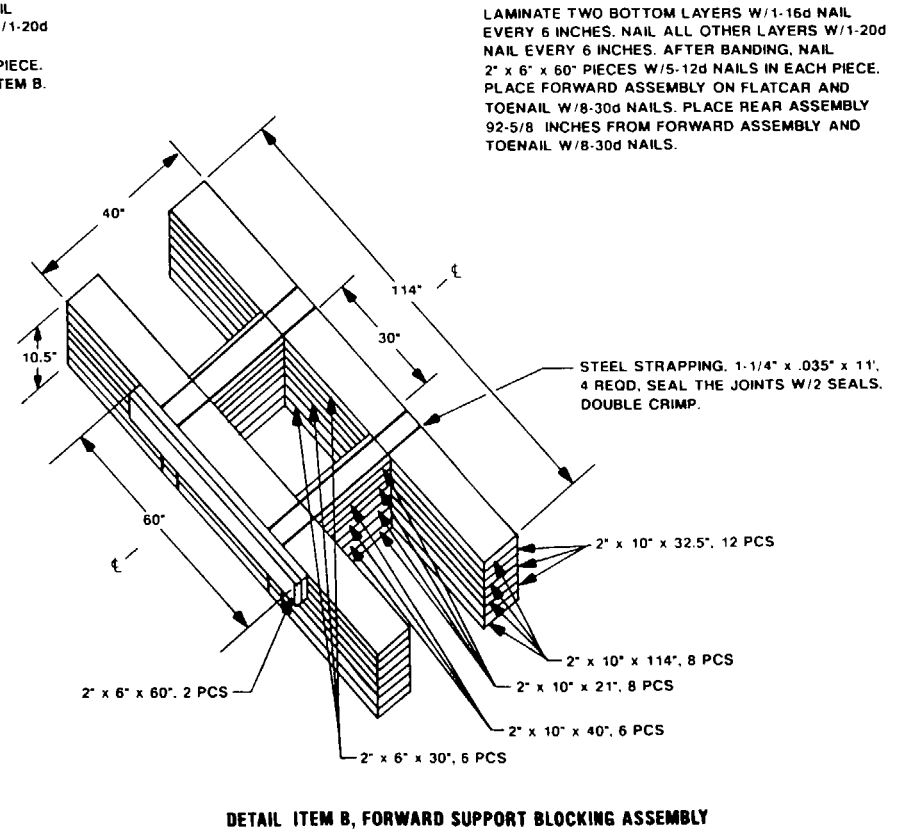
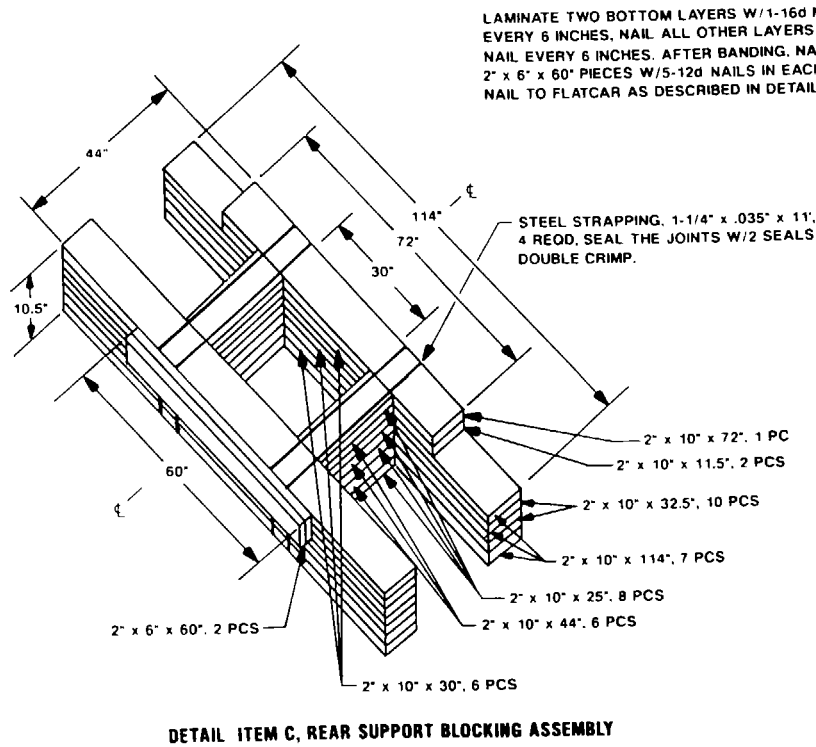

Figure 7-10. RS special blocking detail.

h. The AMG is removed from the M942 chassis for rail transport. Restraints on the antenna are installed as shown in figure 2-24. Blocking and tiedown required for transport of the AMG on

CONUS general-purpose flatcars is identified in figure 7-11. The bill and application of materials are provided in tables 7-13 and 7-14, respectively.

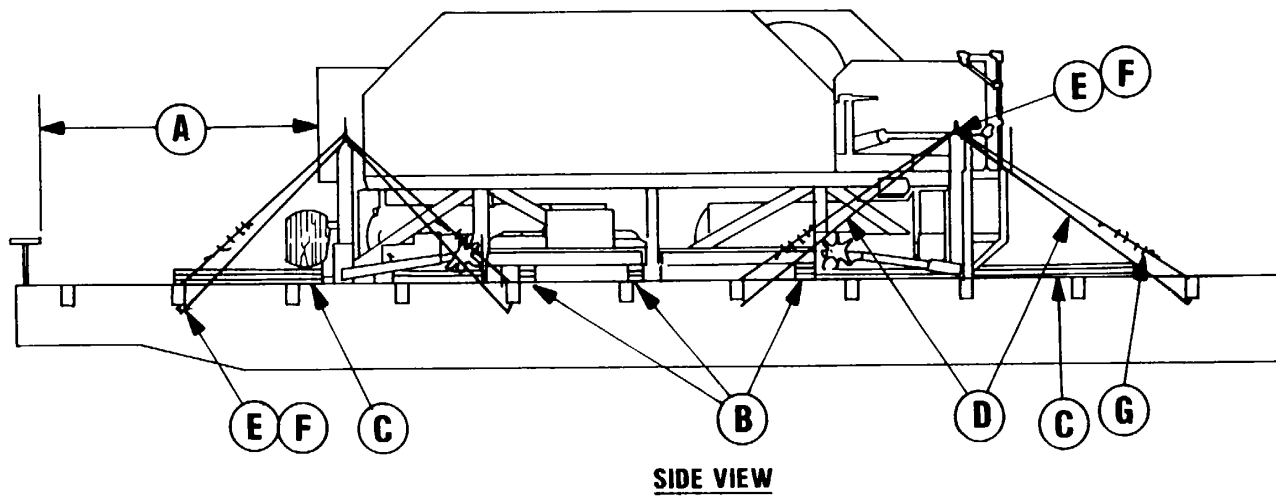
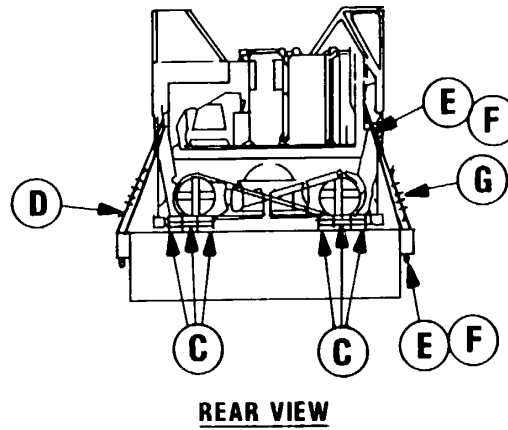

Figure 7-11. Blocking and tiedown of the AMG on CONGUS general-purpose flatcars.

i. Blocking and tiedown required for rail transport of the ECS, ICC, and CRG shelter-mounted components on CONUS general-purpose flatcars is identified in figure 7-12. The bill and application of materials are provided in tables 7-15 and 7-16, respectively.

Table 7-9. Bill of Materials for Blocking and Tiedown of the M860A1 Semitrailer with the LS, Outriggers, and Generator, or with the RS Removed and the Outriggers in Place on CONUS General-Purpose Flatcars (Figs 7-2 and 7-8)

Item	Description	Approximate Quantity
Lumber	Douglas-fir, or comparable, straight-grain, free from material defects; Fed Spec MM-L-751H: 2- x 4-inch 2- x 6-inch 4- x 4-inch 6- x 8-inch	120 linear feet 16 linear feet 60 linear feet 12 linear feet
Nails	Common, steel; flathead; bright or cement-coated; Fed Spec FF-N-105: 12d 20d 30d 40d	118 92 24 56
Wire rope.	6 x 19, IWRC; improved plow steel; performed, regular-lay; table X, Fed Spec RR-W-410C; 5/8-inch.	410 feet
Clamps	Wire rope, U-bolt clips, saddled, single-grip, steel, Crosby heavy-duty, or equal; Fed Spec FF-C-450D: 5/8-inch 3/4-inch	72 14
Thimbles	Standard, open-type: 5/8-inch	4
Cushioning material.	Waterproof paper or suitable material.	as required
Shackle	Anchor, screw pin, 1 5/8-inch diameter pin, 2-inch opening.	10

Table 7-10. Application of Materials for Blocking and Tiedown of the M860A1 Semitrailer with the LS, Outriggers, and Generator, or with the RS Removed and the Outriggers in Place on CONUS General-Purpose Flatcars (Figs 7-2 and 7-8)

Item	No. Required	Application
A		Bake wheel clearance.- Minimum clearance required is 6 inches above, in back of, and on both sides of and 4 inches underneath wheel; 12 inches from end of railcar to load, which extends from center of brake wheel to side of railcar; and 6 feet above railcar floor.

Table 7-10. Application of Materials for Blocking and Tiedown of the M860A1 Semitrailer with the LS, Outriggers, and Generator, or with the RS Removed and the Outriggers in Place on CONUS General-Purpose Flatcars (Figs 7-2 and 7-8)-Continued

Item	No. Required	Application
B	8	Blocks. Each consists of one piece of 6- x 8- x 24-inch lumber (detail 1, fig 7-2). Place the 45° end of the block against the outboard side of tire tread and nail through heel of block with three 40d nails. Toenail sides of block with two 40d nails on each side. Place a second block inboard the first against the tire tread and nail through heel of block with three 40d nails. Toenail the inboard side of the second block with two 40d nails. Place a pair of blocks against the forward side of tires on the forward axle and a pair of blocks against the rear side of the tires on the rear axle.
C	as required	Cushioning material. Place bottom portion under item D and between the tire and item D so that the material extends 2 inches above item D.
D	2	Side blocks. Each consists of one piece of 2- x 5- x 96-inch lumber and three pieces of 2- x 4- x 96-inch lumber (detail 2, fig 7-2). Nail the 2- x 6- x 96-inch piece to the side edge of one 2- x 4- x 96-inch piece with fourteen 12d nails. Place the 2- x 6-inch side against the cushioning material and tires and nail through the 2- x 4- x 96-inch piece to the railcar floor with twelve 20d nails. Nail the other two 2- x 4- x 96-inch pieces to the one below in the same manner with twelve 30d nails. Use a staggered nailing pattern to avoid striking the nail in the piece below.
E	10	Shackles. Place one shackle in each tiedown point used, as shown in figure 7-8.
F	12	Wire rope, 5/8-inch. From a complete loop between the shackles (item E) and a thimble (item H) in the railcar stake pocket at a maximum angle of 45°. Ends of wire rope should overlap about 24 inches (detail 3, fig 7-2).
G	2	Wire rope, 5/8-inch. Install the same as item F, except angle is to be 70 to 90° from railcar floor.
H	14	Thimbles, 5/8-inch. Place thimble at the bottom edge of the stake pocket. Secure to the wire rope with one 3/4-inch clamp, item I.
I	14	Clamps, 5/8-inch. Place one on each item H.

Table 7-10. Application of Materials for Blocking and Tiedown of the M860A1 Semitrailer with the LS, Outriggers, and Generator, or with the RS Removed and the Outriggers in Place on CONUS General-Purpose Flatcars (Figs 7-2 and 7-8)-Continued

Item	No. Required	Application
J	72	Clamps, 5/8-inch. Place four clamps on each items F and G at the overlap area. Space clamps 4 inches apart.
K	1	Forward support blocking assembly. Construct off railcar and place beneath the kingpin plate area of the semitrailer. Lift the forward end of the semitrailer, completely retracting the landing gear, and lower the front end of the trailer to rest on the forward blocking assembly. Details for construction are shown in figure 7-5 and items K through W in table 7-6.
	x1	CAUTION

Table 7-10. Application of Materials for Blocking and Tiedown of the M860AI Semitrailer with the LS, Outriggers, and Generator, or with the RS Removed and the Outriggers in Place on CONUS General-Purpose Flatcars (Figs 7-2 and 7- 8-Continued

Item	No. Required	Application
	x1	Tension wire ropes to cause a slight (1/2- to 3-inch) vehicle body spring deflection at rear and a firm contact of the fifth wheel plate on the forward blocking. Then tighten clamps, item J, to 95 foot-pounds torque.
L	4	Stabilizer restraint. Using 5/8-inch wire rope, form a complete loop between to top of the right stabilizer and the bottom of the left stabilizer for both front and rear locations. Repeat for top left to bottom right. Ends of wire rope should overlap about 24 inches (detail 3, fig 7-2). Place four clamps (item J) on each item L at overlap area. Space clamps 4 inches apart.

GENERAL INSTRUCTIONS

1. Loading rules 1A, 2, 3, 4, 5, 7, 9, 12, 13, 14, 15, 19, 19A, 19B, and 19C appearing in section 1 of the *General Rules Governing the Loading of Commodities on Open-Top Cars*, published by the Association of American Railroads, provides applicable guidelines and are mandatory in application.

2. Forward blocking assembly, item K, should be preassembled and placed beneath the fifth wheel plate and nailed to the flatcar floor.

Table 7-11. Bill of Materials for Blocking and Tiedown of the RS on CONUS General-Purpose Flatcars (Figs 7-2, 7-9, and 7-10)

Table 7-11. Bill of Materials for Blocking and Tiedown of the RS on CONUS General-Purpose Flatcars (Figs 7-2, 7-9, and 7-10)-Continued

Item	Description	Approximate Quantity
Clamps	Wire rope, U-bolt clips, saddled, single-grip, steel, Crosby, heavy-duty, or equal; Fed Spec FF-C-450d:	
	1/2-inch	56
	5/8-inch	28
Thimbles	Standard, open-type: 1/2 inch	28
Banding	High tension band, steel, 1.25- x 0.031-inch with two seats per band.	100 feet

Item	Description	Approximate Quantity
Lumber	Douglas-fir, or comparable, straight-grain, free from material defects; Fed Spec MM-L-751H:	
	2- x 6-inch	240 linear feet
	2- x 10-inch	410 linear feet
Nails	Common, steel; flathead; bright or cement-coated; table XI-B, Fed Spec FF-N-105:	
	12d	30
	16d	82
	20d	750
	30d	280
Wire rope.	6 x 19, IWRC; improved plow steel; preformed, regular-lay; table X, Fed Spec RR-W-410: 1/2-inch diameter.	360 linear feet

Table 7-12. Application of Materials for Blocking and Tiedown of the RS on CONUS General Purpose Flatcars (Figs 7-2, 7-9. and 7-10)

Item	No. Required	Application
A		Brake wheel clearance. Minimum clearance required is 6 inches above, in back of, and on both sides of and 4 inches underneath wheel; 12 inches from end of railcar to load, which extends from center of brake wheel to side of railcar; and 6 feet above railcar floor.
B	1	Forward support blocking assembly. Assemble as shown in detail item B, figure 7-10.
C	1	Rear support blocking assembly. Assemble as shown in detail item C, figure 7-10.
D	12	Place items B and C on the flatcar 92-5/8 inches apart. Toenail each assembly to the flatcar with eight 30d nails. Backup cleats. Each consists of three pieces of 2- x 6- x 72-inch lumber. Evenly space three cleats 6 inches apart on both sides of centerline in the middle portion of items B and C.
E	8	Nail the first piece to the flatcar with eleven 20d nails in a staggered pattern. Nail the next two layers with eleven 30d nails in each piece in a staggered pattern so as not to strike a nail in the piece below. Wire rope, 1/2-inch. Form a complete loop between the thimbles (item I) in the lower tiedown points at each end of the RS and the thimbles in the railcar stake pocket at a maximum angle of 45°. Place two complete loop tiedowns from each tiedown point to the near side of the railcar. Ends of wire ropes should overlap about 24 inches (detail 3, fig 7-2).

Table 7-12. Application of Materials for Blocking and Tiedown of the RS on CONUS General Purpose Flatcars (Figs 7-2, 7-9, and 7-10)-Continued

Item	No. Required	Application
F	2	Wire rope, 1/2-inch. Form a complete loop from the thimble at the upper rear tiedown point to a thimble at the near-side railcar stake pocket at a maximum angle of 45°. Ends of wire rope should overlap about 24 inches (detail 3, fig. 7-2).
G	2	Wire rope, 1/2-inch. Form a complete loop between the thimbles at the upper forward tiedown and the railcar stake pocket at least 20° from vertical above the stake pocket aft of the RS tiedown point. Ends of wire rope should overlap about 24 inches (detail 3, fig 7-2).
H	2	Wire rope, 1/2-inch. Form a complete loop between the thimbles at the upper forward tiedown point and the railcar stake pocket at least 20° from vertical above the stake pocket forward of the RS tiedown point. Ends of wire rope should overlap about 24 inches (detail 3, fig 7-2).
I	28	Thimble, 1/2-inch. Place one thimble at the bottom edge of the stake pocket and the RS tiedown points. Secure to the wire rope with one 5/8-inch clamp, item J.
J	28	Clamps, 5/8-inch. Place one on each item I.
K	56	Clamps, 1-2-inch. Place four on wire rope tiedown (items E, F, G, and H) at the overlap area, at least 4 inches apart.

GENERAL INSTRUCTIONS

Loading rules 1A, 2, 3, 5, 7, 9, 12, 13, 14, 15, 19, 19A, 19B, and 19C appearing in section 1 of the General Rules Governing the Loading of Commodities on Open-Top Cars, published by the Association of American Railroads, provide applicable guidelines and are mandatory in application.

NOTE

Tension wire rope using a chain hoist with two cable grippers.

Tension to allow no more than 1-inch deflection when supporting the weight of a full grown man.

Torque clamps as follows:

3/8-inch clamp, 45 foot-pounds

1/2-inch clamp, 65 foot-pounds

5/8-inch clamp, 95 foot-pounds

Table 7-13. Bill of Materials for Blocking and Tiedown of the AMG on CONUS General-Purpose Flatcars (Figs 7-2 and 7-11)

Item	Description	Approximate Quantity
Lumber	Douglas-fir, or comparable, straight-grain, free from material defects; Fed Spec MM-L-751H: 2- x 6-inch.	290 linear feet
Nails	Common, steel; flathead; bright or cement-coated; table X1-b, Fed Spec FF-N-105:	
	20d	180
	30d	340
Wire rope.	6 x 19, IWRC; improved plow steel; preformed, regular-lay; table X, Fed Spec RR-W-410: 5/8-inch dia:	160 feet
Thimbles	Standard, open-type: 5/8-inch	16

Table 7-13. Bill of Materials for Blocking and Tiedown of the AMG on CONUS General-Purpose Flatcars (Figs 7-2 and 7-II)-Continued

Item	Description	Approximate Quantity
Clamps	Wire rope, U-bolt clips, saddled, single-grip, steel, Crosby, heavy-duty, or equal; Fed Spec FF-C-450: 5/8-inch 3/4-inch	32 16

Table 7-14. Application of Materials for Blocking and Tiedown of the AMG on CONUS General-Purpose Flatcars (Figs 7-2 and 7-11)

Item	No. Required	Application
A		Brake wheel clearance. Minimum clearance required is 6 inches above, in back of, and on both sides of and 4 inches underneath wheel; 12 inches from end of railcar to load, which extends from center of brake wheel to side of railcar; and 6 feet above railcar floor.

Table 7-14. Application of Materials for Blocking and Tiedown of the AMG on CONUS General-Purpose Flatcars (Figs 7-2 and 7-11)-Continued

Item	No. Required	Application
B	6	Side blocking. Each consists of three pieces of 2- x 6- x 30-inch lumber. Determine the width of the AMG center sills. Split the width along the centerline of the railcar, and space blocks so that one is in the center and the front and aft blocks are inside the corner frames on each side of the AMG. Nail the first layer to the railcar with five 20d nails. Nail the top two layers to the one below with five 30d nails. Lower the AMG into position on the flatcar between the side blocks.
C	12	End cleats. Each consists of three pieces of 2- x 6- x 72-inch lumber. Place the first piece firmly against the end frame, even with the outside corner, and nail to the railcar floor with ten 20d nails. Nail the top two layers to the one below with ten 30d nails. Place two more cleats against the first in the same manner at all four corners.
D	8	Wire rope, 5/8-inch. Form a complete loop between the thimbles (item E) at the tiedown point and the railcar stake pocket at a maximum angle of 45°. Ends of wire rope should overlap about 24 inches (detail 3, fig. 7-2).
E	16	Thimbles, 5/8-inch. Place one thimble at the bottom edge of the stake pocket and tiedowns on the AMG. Secure to the wire rope with one 3/4-inch clamp, item F.
F	16	Clamps, 3/4-inch. Place one on each item E.
G	32	Clamps, 3/4-inch. Place four on wire rope tiedowns (item D) at the overlap area, at least 4 inches apart.

GENERAL INSTRUCTIONS

Loading rules 1A, 2, 3, 5, 6, 9, 12, 13, 14, 15, 19, 19A, 19B, and 19C appearing in section 1 of the General Rules Governing the Loading of Commodities on Open-Top Cars, published by the Association of American Railroads, provide applicable guidelines and are mandatory in application.

NOTE

Tension wire rope using a chain hoist with two cable grippers.
Tension to allow

no more than 1-inch deflection when supporting the weight of a full grown man.

Torque clamps as follows:

- 5/8-inch clamp, 45 foot-pounds**
- 1/2-inch clamp, 65 foot-pounds**
- 5/8-inch clamp, 95 foot-pounds**

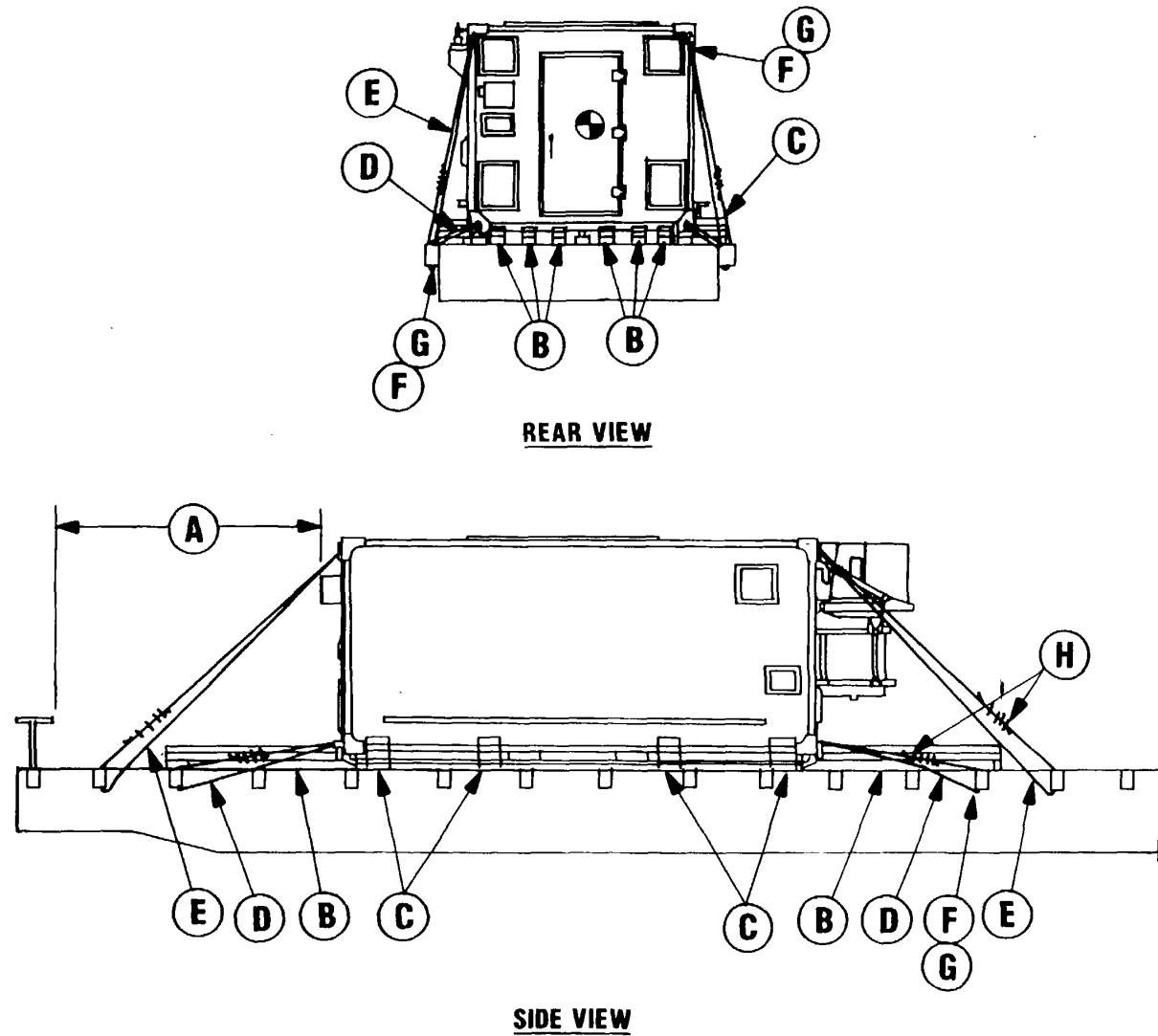

Figure 7-12. Typical blocking and tiedown of the ECS, ICC, and CRG shelter-mounted components on CONUS general-purpose flatcars.

7-6. Loading on Flatcars with Chain Tiedowns

a. All PATRIOT vehicles are transportable on railcars, either wood or steel decked and equipped with two or four tiedown rails, with chain tiedowns. For vehicles exceeding 16,000 pounds, it is preferred to use a railcar equipped with 1/2-inch chains, as this reduces the number of chains that must be used. Semitrailers should be attached to their truck-tractors. Semitrailers separated are transportable on wood-deck cars only, with use of the forward support blocking assembly, as described in figure 7-5 and table 7-6. The maintenance semitrailers are also transportable on trailer on flatcars (TOFC) and, thus, will not require chain restraint on these railcars. The M860A1 semitrailer, with a 3 1/2-inch kingpin, is not compatible with TOFC cars.

b. Chains will be attached to the vehicles at the same location as previously described when using wire rope. Table 7-17 gives the number of chains that must be used for restraining a vehicle, by weight. Blocking is not required.

c. Anchors, turnbuckles, and chains must be lowered into the tiedown rails before vehicles are driven onto the flatcar. Apply chain hooks over the vehicle tiedown shackles, rather than under. Chains should be applied with an angle from deck to vehicle of about 45°. Turnbuckles of the forward and rear chain tiedowns must be tightened at the same time to prevent uneven tensioning, with the shortest chains secured first. The hook must be wired to the chain link to prevent disengagement.

Table 7-15. Bill of Materials for Typical Blocking and Tiedown of the ECS, ICC, and CRG Shelter-Mounted Components on CONUS General-Purpose Flatcars (Figs 7-2 and 7-12)

Item	Description	Approximate Quantity
Lumber feet	Douglas-fir, or comparable, straight-grain, free from material defects; Fed Spec MM-L-751H: 2- x 6-inch.	260 linear
Nails	Common, steel; flathead; bright or cement-coated; table X1-b, Fed Spec FF-N-105: 20d 30d	152 304
Wire rope.	6 x 19, IWRC; improved plow steel; performed, regular-lay; table X, Fed Spec RR-W-410: 1/2 inch.	180 feet
Thimbles	Standard, open-type: 5/8-inch	16
Clamps	Wire rope, U-bolt clips, saddled, single-grip, steel, Crosby, heavy-duty, or equal Fed Spec FF-C-450: 1/2-inch 5/8-inch	32 16

Table 7-16. Application of Materials for Typical Blocking and Tiedown of the ECS, ICC, and CRG Shelter-Mounted Components on CONUS General-Purpose Flatcars (Figs. 7-2 and 7-12)

Item	No. Required	Application
A	12	Brake wheel clearance. Minimum clearance required is 6 inches above, in back of, and on both sides of and 4 inches underneath wheel; 12 inches from end of railcar to load, which extends from center of brake wheel to side of railcar; and 6 feet above railcar floor.
B of		End cleats. Each consists of three pieces 2- x 6- x 72-inch lumber. Place the first piece even with the end of the shelter, 3 inches inboard of the tiedown fitting, and nail to the railcar floor with ten 20d nails. Place the top two layers so they firmly contact the shelter and nail each to the one below with ten 30d nails. Place two more cleats, 6 inches apart, inboard from each of the four corners.
C	8	Side blocks. Each consists of three pieces of 2- x 6- x 12-inch lumber. Place four on each side as shown in figure 7-10. Place the first piece firmly against the shelter skid and nail to the flatcar with four 20d nails. Place the top two layers firmly against the skid or side of shelter and nail to the one below with four 30d nails.
D	4	Wire rope, 1/2-inch. Form a complete loop between the thimbles (item F) at the lower corner tiedown ring and the railcar stake pocket at a maximum floor angle of 45°. Ends of wire rope should overlap about 24 inches (detail 3, fig 7-2).
E	4	Wire rope, 1/2-inch. Form a complete loop between the thimbles at the upper corner tiedown ring and the railcar stake pocket at a maximum angle of 45°. Ends of wire rope should overlap about 24 inches (detail 3, fig 7-2).
F	16	Thimble, 1/2-inch. Place one thimble on the wire rope at the bottom edge of the stake pocket and one at each tiedown ring on the shelter. Secure to the wire rope with one 5/8-inch clamp, item G.
G	16	Clamp, 5/8-inch. Place one on each item
F. H	32	Clamp, 1/2-inch. Place four on wire rope tiedowns (items D and E) at the overlap area, at least 4 inches apart.

GENERAL INSTRUCTIONS

Loading rules 1A, 2, 3, 5, 6, 9, 12, 13, 14, 15, 19, 19A, 19B, and 19C appearing in section 1 of the General Rules Governing the Loading of Commodities on Open-Top Cars, published by the Association of American Railroads, provide applicable guidelines and are mandatory in application.

no more than one inch deflection when supporting the weight of a full grown man. Torque clamps as follows:

- 3/8-inch clamp, 45 foot-pounds**
- 1/2-inch clamp, 65 foot-pounds**
- 5/8-inch clamp, 95 foot-pounds**

NOTE

**Tension wire rope using a chain hoist with two cable grippers.
Tension to allow**

Section III. TRANSPORT OF FOREIGN RAILWAYS

7-7. General

The transportability guidance in this section applies when the PATRIOT system components are transported on foreign railways. Consideration is given to single and multiple vehicle movements on the types of flatcars normally used for moving that vehicle. When loaded on a suitable flatcar, the system components are transportable, with some restrictions, within European countries with the Gabarit International de Chargement (GIC) (formerly PPI) gauge railways. This also applies to most of the countries in the Middle East, South America, Australia, India, and Pakistan. Wideor broad-gauge railways provide greater clearances and fewer restrictions. Because of the various systems and clearances used by different countries, evaluation of transport capability must be made on an individual basis.

required for blocking and tiedown of the vehicles on foreign-service flatcars are essentially the same as those used for rail within CONUS. Detailed guidance is contained in the 4th Transportation Command Pamphlet 55-2, *Tiedown Guide of Rail Movement*, and may be obtained by contacting Commander, 1st Transportation Movement Control Agency, ATTN: AEUTR-MCA-TA, APO New York, 09451-4000. For intratheater or incountry clearance, assistance can be obtained from the 1st Transportation Movement Control Agency, Oberursel, Germany.

Table 7-17. Restraint Required on Cushioned Draft Railcars

Weight Range of Vehicles (lb)	Alloy Steel Chain		No. of Chains Required
	Dia (in.)	Minimum Proof-Test Value (lb)	
0-8,500	3/8	13,200	4
8,500-16,000	3/8	18,000	4
16,000-35,000 ..	3/8	18,000	8
35,000-53,000 ..	3/8	18,000	12
53,000-71,000 ..	3/8	18,000	16
71,000-80,000 ..	3/8	18,000	20
16,000-25,000...	1/2	22,500	4
25,000-40,000 ..	1/2	27,500	4
40,000-55,000 ..	1/2	27,500	8
55,000-80,000 ..	1/2	27,500	12

7-8. Transport on Foreign-Service Flatcars

The PATRIOT system components are transportable on many foreign-service flatcars. To comply with the dimensional requirements of the GIC clearance diagram, the system components must be reduced to their minimum shipping configuration. In their reduced configuration, the system components can be moved, without restrictions, on standard flatcars throughout Europe. The materials

**APPENDIX
REFERENCES**

1. Army Regulations (AR)

- | | |
|--------|---|
| 55-162 | Permits for Oversize, Overweight, or Other Special Military Movements on Public Highways in the United States |
| 55-228 | Transportation by Water of Explosives and Hazardous Cargo |
| 755-15 | Disposal of Supplies and Equipment. Disposal of Unwanted Radioactive Material |

2. Technical Manuals (TM)

- | | |
|---------------|--|
| 3-261 | Handling and Disposal of Unwanted Radioactive Material |
| 9-2320-279-10 | Operator's Manual M977 Series, 8x8 Heavy Expanded Mobility Tactical Trucks (HEMTT) |
| 9-2320-279-34 | Maintenance Instructions Direct Support and General Support M977 Series, 8x8 Heavy Expanded Mobility Tactical Trucks (HEMTT) |
| 9-2320-355-10 | Operator's Manual, Controls and Equipment Found Only on the M985E1 Cargo 8x8 Heavy Expanded Mobility Tactical Truck (HEMTT) |
| 38-250 | Packaging and Handling of Dangerous Materials for Transportation by Military Aircraft |

3. Technical Orders (TO) (Air Force)

- | | |
|-----------|---|
| IC-5A-9 | Loading Instructions USAF Series C-5 Aircraft |
| IC-141B-9 | Loading Instructions USAF Series C-141 Aircraft |

4. Other Publications

Outline Diagram for Single Loads, Without End Overhang, on Open-Top Cars. Association of American Railroads, Chicago, IL.

Code of Federal Regulations, Title 46. US Government Printing Office, Washington, DC.

Code of Federal Regulations, Title 49. US Government Printing Office, Washington, DC.

By Order of the Secretary of the Army:

GORDON R. SULLIVAN
General, United States Army
Chief of Staff

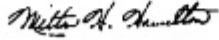
Official: 

MILTON H. HAMILTON
Administrative Assistant to the
Secretary of the Army

03885

DISTRIBUTION:

To be distributed in accordance with DA Form 12-40-E, Block **3519**
requirements for **TM 55-1430-80114**.

RECOMMENDED CHANGES TO EQUIPMENT TECHNICAL PUBLICATIONS

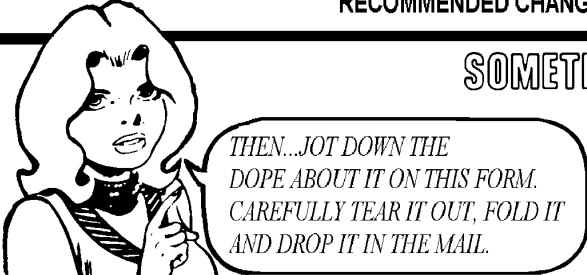
<h2 style="margin: 0;">SOMETHING WRONG WITH PUBLICATION</h2>			
 <p style="margin: 0;"><i>THEN...JOT DOWN THE DOPE ABOUT IT ON THIS FORM. CAREFULLY TEAR IT OUT, FOLD IT AND DROP IT IN THE MAIL.</i></p>		FROM: (PRINT YOUR UNIT'S COMPLETE ADDRESS)	
		DATE SENT	
PUBLICATION NUMBER		PUBLICATION DATE	PUBLICATION TITLE
BE EXACT PIN-POINT WHERE IT IS			
PAGE NO.	PARA-GRAPH	FIGURE NO.	TABLE NO.
<div style="display: flex; justify-content: space-between;"> <div style="width: 30%;"></div> <div style="width: 65%;"> <p style="margin: 0;">IN THIS SPACE, TELL WHAT IS WRONG AND WHAT SHOULD BE DONE ABOUT IT.</p> <hr style="width: 20%; margin: 20px auto;"/> </div> </div>			
PRINTED NAME, GRADE OR TITLE AND TELEPHONE NUMBER			SIGN HERE

The Metric System and Equivalents

Linear Measure

1 centimeter = 10 millimeters = .39 inch
 1 decimeter = 10 centimeters = 3.94 inches
 1 meter = 10 decimeters = 39.37 inches
 1 dekameter = 10 meters = 32.8 feet
 1 hectometer = 10 dekameters = 328.08 feet
 1 kilometer = 10 hectometers = 3,280.8 feet

Weights

1 centigram = 10 milligrams = .15 grain
 1 decigram = 10 centigrams = 1.54 grains
 1 gram = 10 decigrams = .035 ounce
 1 decagram = 10 grams = .35 ounce
 1 hectogram = 10 decagrams = 3.52 ounces
 1 kilogram = 10 hectograms = 2.2 pounds
 1 quintal = 100 kilograms = 220.46 pounds
 1 metric ton = 10 quintals = 1.1 short tons

Liquid Measure

1 centiliter = 10 milliliters = .34 fl. ounce
 1 deciliter = 10 centiliters = 3.38 fl. ounces
 1 liter = 10 deciliters = 33.81 fl. ounces
 1 dekaliter = 10 liters = 2.64 gallons
 1 hectoliter = 10 dekaliters = 26.42 gallons
 1 kiloliter = 10 hectoliters = 264.18 gallons

Square Measure

1 sq. centimeter = 100 sq. millimeters = .155 sq. inch
 1 sq. decimeter = 100 sq. centimeters = 15.5 sq. inches
 1 sq. meter (centare) = 100 sq. decimeters = 10.76 sq. feet
 1 sq. dekameter (are) = 100 sq. meters = 1,076.4 sq. feet
 1 sq. hectometer (hectare) = 100 sq. dekameters = 2.47 acres
 1 sq. kilometer = 100 sq. hectometers = .386 sq. mile

Cubic Measure

1 cu. centimeter = 1000 cu. millimeters = .06 cu. inch
 1 cu. decimeter = 1000 cu. centimeters = 61.02 cu. inches
 1 cu. meter = 1000 cu. decimeters = 35.31 cu. feet

Approximate Conversion Factors

<i>To change</i>	<i>To</i>	<i>Multiply by</i>	<i>To change</i>	<i>To</i>	<i>Multiply by</i>
inches	centimeters	2.540	ounce-inches	Newton-meters	.007062
feet	meters	.305	centimeters	inches	.394
yards	meters	.914	meters	feet	3.280
miles	kilometers	1.609	meters	yards	1.094
square inches	square centimeters	6.451	kilometers	miles	.621
square feet	square meters	.093	square centimeters	square inches	.155
square yards	square meters	.836	square meters	square feet	10.764
square miles	square kilometers	2.590	square meters	square yards	1.196
acres	square hectometers	.405	square kilometers	square miles	.386
cubic feet	cubic meters	.028	square hectometers	acres	2.471
cubic yards	cubic meters	.765	cubic meters	cubic feet	35.315
fluid ounces	milliliters	29.573	cubic meters	cubic yards	1.308
pints	liters	.473	milliliters	fluid ounces	.034
quarts	liters	.946	liters	pints	2.113
gallons	liters	3.785	liters	quarts	1.057
ounces	grams	28.349	liters	gallons	.264
pounds	kilograms	.454	grams	ounces	.035
short tons	metric tons	.907	kilograms	pounds	2.205
pound-feet	Newton-meters	1.356	metric tons	short tons	1.102
pound-inches	Newton-meters	.11296			

Temperature (Exact)

°F	Fahrenheit temperature	5/9 (after subtracting 32)	Celsius temperature	°C
----	---------------------------	-------------------------------	------------------------	----

